

*A bit more on
Frequency-domain EEG*

and then...

*The Event-related Brain Potential
(Part 1)*

Resting brain asymmetry as an
endophenotype for depression

Depression as a Heterogeneous
Phenotype

- Variable Age of Onset
- Variable Symptom Presentation
- Variable Course
- Variable Response to Treatment

Announcements

- Papers: 1 or 2 paragraph prospectus due a few minutes ago!
 - Feedback coming soon if you've not received it already
- 3x5s

Endophenotypes

- Intermediate-level measure of characteristics related to risk for disorder
- Less complex phenotype for genetic association
- Can include, biochemical and imaging measures, among others
- Desiderata
 - Specificity
 - Heritability
 - State-independence
 - Familial Association
 - Co-segregation within families
 - Predicts development of disorder

Gottesman & Shields, 1972; Gottesman & Gould, 2003; Iacono, 1998

Depression: Variable Age Onset

Age at Select Percentiles for Onset of MDD

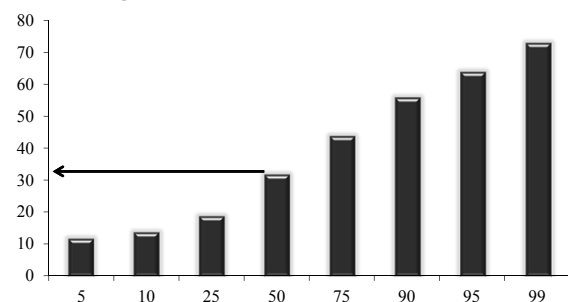

Data from Kessler et al., Arch Gen Psychiatry, 2005, 62:593-602

Depression: Variable Age Onset

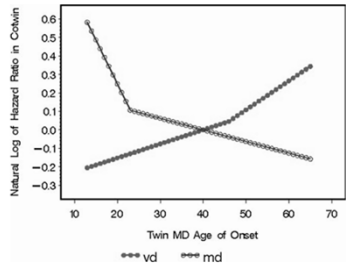
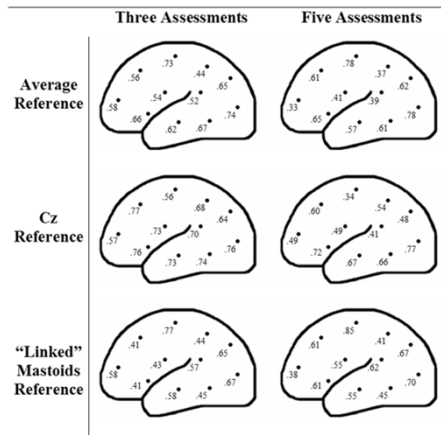

Figure 1. The relationship between the age at onset of major depression (MD) in an affected twin and the natural logarithm of the hazard ratio in the cotwin for MD (in open circles) and vascular disease (VD) (in filled-in circles). These results are obtained from a Cox proportional hazard model controlling for age, sex, and birth cohort. We fitted to these results piecewise models with a single inflection point using a grid search to find the single inflection point that maximized the model's -2 log likelihood.

Kendler, Fiske, Gardner, & Gatz, 2009, *Biological Psychiatry*



Allen, Urry, Hitt, & Coan (2004), *Psychophysiology*

Frontal EEG asymmetry as risk marker for MDD

Resting EEG asymmetry is a stable trait

in clinical populations

(Allen, Urry, et al., 2004; Jetha, Schmidt, & Goldberg, in press; Niemic & Lithgow, 2005; Vuga, et al., 2006)

and nonclinical populations

(Hagemann, Naumann, Thayer, & Bartussek, 2002; Jones, Field, Davalos, & Pickens, 1997; Papousek & Schulte, 1998, 2002; Tomarken, Davidson, Wheeler, & Doss, 1992; Tomarken, Davidson, Wheeler, & Kinney, 1992)

Frontal EEG asymmetry as risk marker for MDD

Changes in clinical status are not associated with changes in resting EEG asymmetry

(Allen, Urry, et al., 2004; Debener, et al., 2000; Vuga, et al., 2006).

Frontal EEG asymmetry as risk marker for MDD

Resting EEG asymmetry is:

modestly heritable

(Anokhin, Heath, & Myers, 2006; J. A. Coan, Allen, Malone, & Iacono, 2009; Smit, Posthuma, Boomsma, & De Geus, 2007)

related to serotonergic candidate genes such as HTR1A allele variations (Bismark, et al., 2010)

Frontal EEG asymmetry as risk marker for MDD

Resting EEG asymmetry relates to internalizing disorders:

→ MDD and depressive symptoms (Allen, Urry, et al., 2004; Bruder, et al., 2005; Debener, et al., 2000; Diego, Field, & Hernandez-Reif, 2001; Diego, Field, & Hernandez-Reif, 2001; Fingelkurts, et al., 2006; Ian H. Gotlib, Ranganath, & Rosenfeld, 1998; J. B. Henriques & Davidson, 1990; Jeffrey B. Henriques & Davidson, 1991; Mathersul, Williams, Hopkinson, & Kemp, 2008; Miller, et al., 2002; Pössel, Lo, Fritz, & Seeman, 2008; Schaffer, Davidson, & Saron, 1983; Vuga, et al., 2006);

Frontal EEG asymmetry as risk marker for MDD

- ➔ Resting EEG asymmetry relates to internalizing disorders:
 - ➔ Anxious arousal/somatic anxiety (Mathersul, et al., 2008; Nitschke, Heller, Palmieri, & Miller, 1999; J.L. Stewart, Levin-Silton, Sass, Heller, & Miller, 2008);
 - ➔ Panic disorder (Wiedemann, et al., 1999);
 - ➔ Comorbid anxiety/depression (Bruder, et al., 1997);
 - ➔ Social phobia (R. J. Davidson, Marshall, Tomarken, & Henriques, 2000);

Frontal EEG asymmetry as risk marker for MDD

- ➔ Resting EEG asymmetry relates to internalizing disorders:
 - ➔ Premenstrual dysphoria (Accortt & Allen, 2006; Accortt, Stewart, Coan, Manber, & Allen, 2010);

PMDD



Accortt & Allen, 2006

PMDD

- ➔ Assessed at
 - ➔ Late-Luteal
 - ➔ Follicular

Accortt & Allen, 2006

Specificity or Spectrum: PMDD

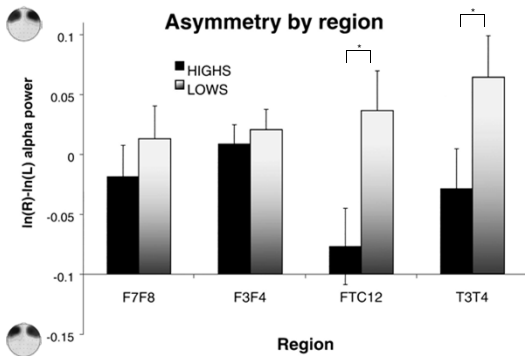

Accortt & Allen, 2006

PMDD

- ➔ Larger Sample
- ➔ Diagnostic Interviews
- ➔ Matched for MDD

Accortt, Stewart, Coan, & Allen, 2010

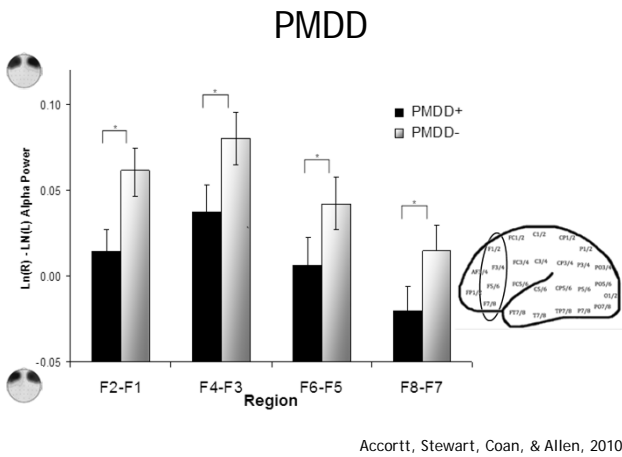

Frontal EEG asymmetry as risk marker for MDD

- Resting EEG asymmetry relates to internalizing disorders:
 - Childhood/adolescent internalizing psychopathology (anxiety, sadness, disappointment, low empathy and sociability, higher stress cortisol, and avoidant-withdrawn behavior (Baving, Laucht, & Schmidt, 2002; Buss, et al., 2003; R.J. Davidson, 1991; Forbes, Fox, Cohn, Galles, & Kovacs, 2005; N.A. Fox, Henderson, Rubin, Calkins, & Schmidt, 2001; Henderson, Marshall, Fox, & K.H., 2004; Schmidt, Fox, Schulkin, & Gold, 1999).

Frontal EEG asymmetry as risk marker for MDD

- Resting EEG asymmetry identifies *family members* of those with internalizing disorders
 - MDD (Dawson, Frey, Panagiotides, Osterling, & Hessler, 1997; Dawson, Frey, Panagiotides, et al., 1999; Dawson, Frey, Self, et al., 1999; Field, Diego, Hernandez-Reif, Schanberg, & Kuhn, 2002; Forbes, et al., 2007; Jones, Field, & Davalos, 2000; Jones, et al., 1997; Miller, et al., 2002; Tomarken, Dichter, Garber, & Simien, 2004).



Meta-Analysis: Depression, Anxiety

- Studies of resting frontal alpha asymmetry
- Measures of depression or anxiety
- Both adult and infant samples
- Literature Sample:
 - 31 papers
 - 59 tests (studies, sites, reference)
 - Adult samples predominantly female

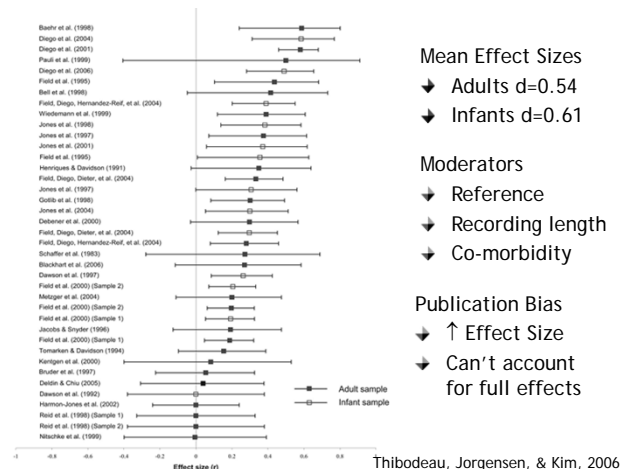

Thibodeau, Jorgensen, & Kim, 2006

Thibodeau, Jorgensen, & Kim, 2006

A "Definitive" Study

- ➔ Large (n=306), medication-free
 - ➔ Both men (n=95) and women (n=211)
 - ➔ Lifetime Depressed (n=143)
 - ➔ Never Depressed (n=163)
- ➔ Assessed for Family History
- ➔ No co-morbidity, medically healthy

Stewart, Bismark, Towers, Coan, & Allen, 2010

A "Definitive" Study

- ➔ Large (n=306), medication-free
- ➔ Assessed for Family History
- ➔ No co-morbidity, medically healthy
- ➔ Resting EEG
 - ➔ Two sessions per day
 - ➔ Four days
- ➔ Four Reference Montages
- ➔ Mixed Linear Models

Stewart, Bismark, Towers, Coan, & Allen, 2010

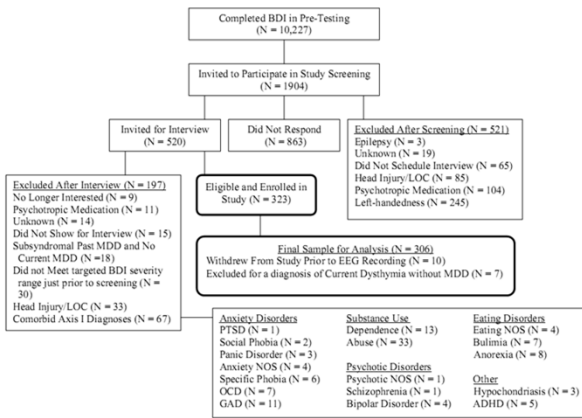

Stewart, Bismark, Towers, Coan, & Allen 2010, *J Abnormal Psychology*

Reference Effects

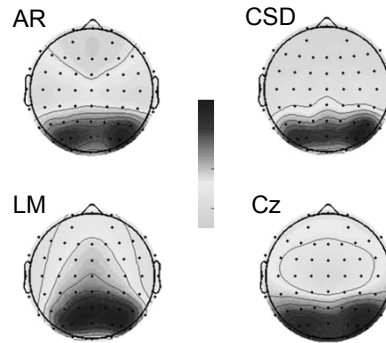

Resting
Eyes Closed
Alpha Power

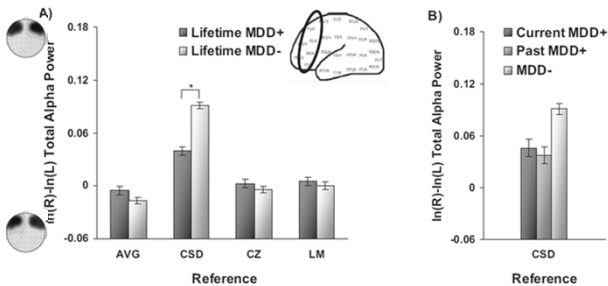

Figure 2. Panel A shows frontal alpha asymmetry scores (8–13 Hz at F2–F1, F4–F3, F6–F5, F8–F7) by lifetime MDD status for each reference montage across all four frontal regions depicted on the head insert. Error bars reflect standard error. Panel B shows results of a follow-up assessment indicating that the relationship of lifetime MDD status to CSD-referenced asymmetry is not solely accounted for by current MDD status. The y-axis is in μV^2 for AVG, Cz, and LM references, and in $\mu V^2/cm^2$ for CSD referenced data. MDD = major depressive disorder; AVG = average; CSD = current source density; CZ = Cz; LM = linked mastoid.

Stewart, Bismark, Towers, Coan, & Allen, 2010

STICK WITH CSD...

Prospective Pilot Data

- ➔ Assessed never depressed (MDD-) individuals ~1 year after EEG
- ➔ Obtained 53 of 163 (representative)
- ➔ Completed BDI based on "worst month"
- ➔ BDI worst month residualized on BDI at EEG assessment
- ➔ Can EEG predict this worst month BDI score?

Prospective Pilot Data

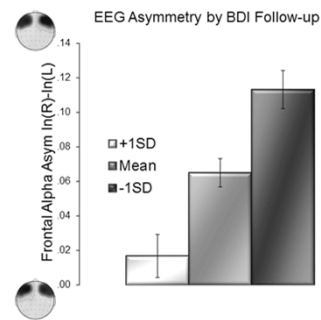

Thus

- ➔ Frontal EEG asymmetry has promise as a risk indicator for MDD and other internalizing disorders
- ➔ Need:
 - ➔ Large-scale prospective study
 - ➔ Links to underlying neural systems

Asymmetry Metric Vs Individual Sites

- Is it left or is it right?
- Can assess using ANOVA with hemisphere as a factor
 - Removes overall power before testing for interaction of emotion/temperament/psychopathology with hemisphere
 - But not easily amenable for assessing relationship of EEG at given site to continuous variables

Asymmetry Metric Vs Individual Sites

- The Problem:
 - Power at an individual site reflects:
 - Underlying neural activity
 - Scalp thickness
- An early (nonoptimal) solution
 - Residualize power at each lead based on
 - Whole head power (reasonable)
 - Homologous lead power (troublesome)

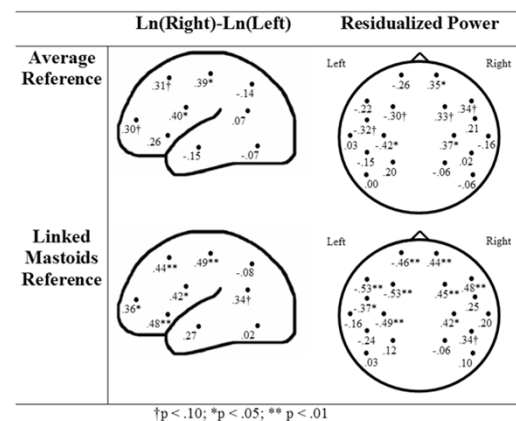

Why does it do *that*?!?

- This double residualization results in correlations with the outcome variable similar in magnitude to the difference score, but with opposite signs for the two hemispheres.
- This is actually to be expected when the predictor and criterion variable are highly correlated

Allen, Coan, & Nazarian (2004)

Alpha Power at Homologous Sites is *Highly* Correlated

Sites	Reference	
	AR	LM
FP1 .. FP2	.997	.998
F7 .. F8	.983	.971
F3 .. F4	.990	.992
FTC1 .. FTC2	.975	.943
C3 .. C4	.977	.981
T3 .. T4	.918	.891
TCP1 .. TCP2	.944	.948
P3 .. P4	.965	.982
T5 .. T6	.907	.932

Allen, Coan, & Nazarian (2004)

Consider residualized left lead power when $L \approx R$

$$L_{resid} = L - \hat{L}$$

$$\hat{L} = a + b(R)$$

In limiting case where $r_L \rightarrow 1.0$

$$\hat{L} = 0 + 1(R) = R$$

$$L_{resid} = L - \hat{L} = L - R$$

Allen, Coan, & Nazarian (2004)

Fancy That!

➤ Residual values for left hemisphere leads approaches $L - R$ as the correlation between left and right leads approaches 1.0.

➤ Residual values for right hemisphere approaches the value $R - L$ as the correlation between left and right leads approaches 1.0.

➤ Therefore, this procedure will make it appear that right hemisphere leads correlate with a criterion variable in the same direction and magnitude as the $R - L$ difference score, and that left hemisphere leads correlate with a criterion variable in the opposite direction but same magnitude as the $R - L$ difference score.

➤ Therefore, *don't do that!*

What to do?

- Residualize only on whole head power, not additionally on homologous lead power

Synchronization and Desynchronization

- Supposition that alpha blocking meant that the EEG had become desynchronized
 - Yet the activity is still highly synchronized -- not at 8-13 Hz
 - May involve fewer neuronal ensembles in synchrony

If Alpha Desynchs, what Synchs?

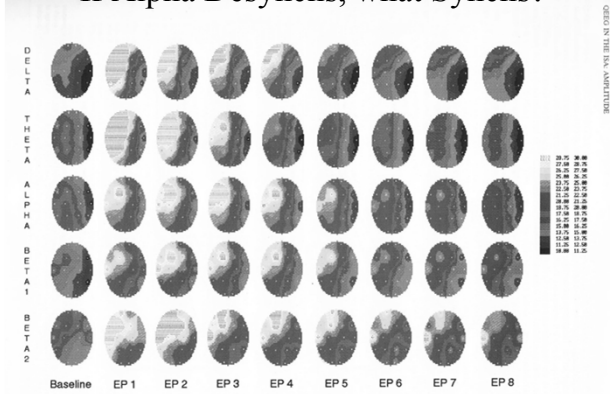

Event-related Synchronization and Desynchronization

- Pfurtscheller (1992) -- Two types of ERS
 - Secondary (follows ERD)

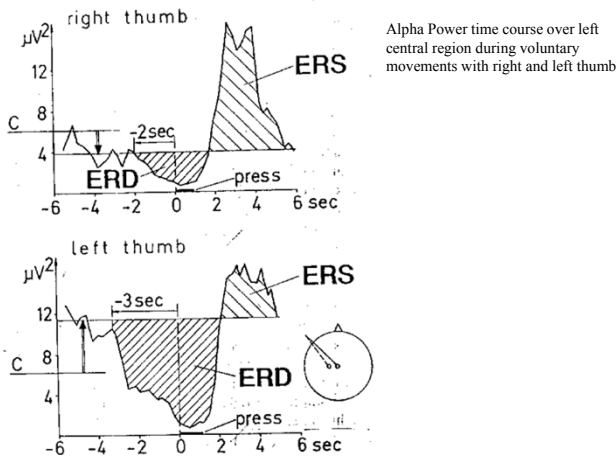

Alpha Power time course over left central region during voluntary movements with right and left thumb

Event-related Synchronization and Desynchronization

- Pfurtscheller (1992) -- Two types of ERS
 - Secondary (follows ERD)
 - Primary (Figure 3 & Figure 4)

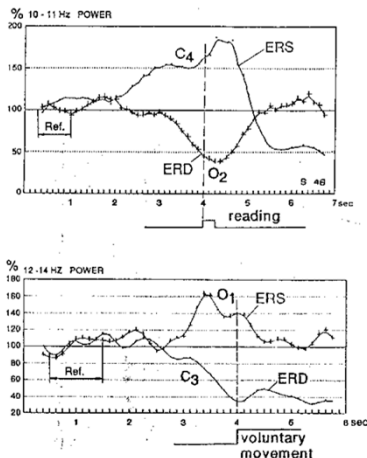

Alpha power time course during reading (upper) and voluntary finger movements (lower). Primary ERS is seen over electrodes overlying cortical areas not involved in the task.

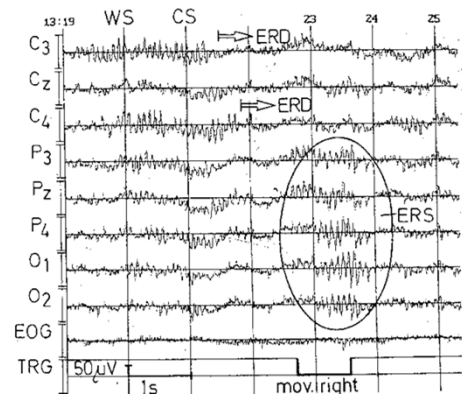

Primary ERS seen over parietal and occipital leads during right finger movement. ERD is seen over central electrodes, with earlier onset over hemisphere contralateral to movement.

Frontal Midline Theta (more later in advanced topics)

- Increased midline frontal theta during periods of high cognitive demand
- This is specifically under conditions in which cortical resources must be allocated for select cognitive processes
 - Attention
 - Memory
 - Error Monitoring

Sheer work with Cats

- Learning paradigm
- Cat must learn
 - press to S_D (7cps light flicker)
 - not $S-$ (3 cps light flicker)
 - the hypothesis is that the synchronized 40 Hz activity represents the focused activation of specific cortical areas necessary for performance of a task

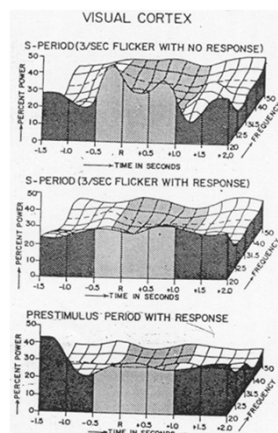

Note very different pattern to $S-$. No 40-Hz change in visual cortex, and marked increase in lower frequencies at same time period.

40 Hz Activity

- First reports of important 40 Hz activity
- Sheer & Grandstaff (1969) review
 - pronounced rhythmic electrical bursting
- Daniel Sheer's subsequent work until his death renewed interest in "40 Hz" phenomena

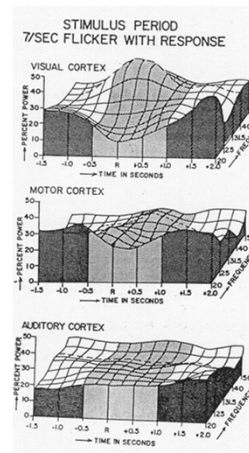

Note specificity of response to S_D , over visual cortex to discriminative stimulus, in 40-Hz range; Some hint of it later in the motor cortex. Note also decreased activity in slower bands during the same time periods.

Human Studies

- Hypothesis is that 40 Hz activity correlates with the behavioral state of focused arousal (Sheer, 1976) or cortical activation
 - a "circumscribed state of cortical excitability" (Sheer, 1975)
 - Bird et al (1978)
 - biofeedback paradigm
 - increased 40 Hz activity is associated with high arousal and mental concentration
 - Ford et al., (1980)
 - subjects once trained to voluntarily suppress 40 Hz EEG are unable to maintain that suppression while simultaneously solving problems
 - concluded that problem solving and absence of 40 Hz are incompatible

Lateralized Task Effects

- Loring & Sheer (1984)
 - right-handed students
 - analogies task
 - spatial Task
- Results transformed into laterality ratios:
 - (L-R)/(L+R) 40 Hz
 - higher # => greater LH activity (P3-O1-T5 triangle vs P4-O2-T6 triangle);
- Results
 - greatest variability during baseline
 - smallest variability and greatest LH activation during verbal
 - no laterality effects in the 40Hz EMG bands

Laterality of 40 Hz

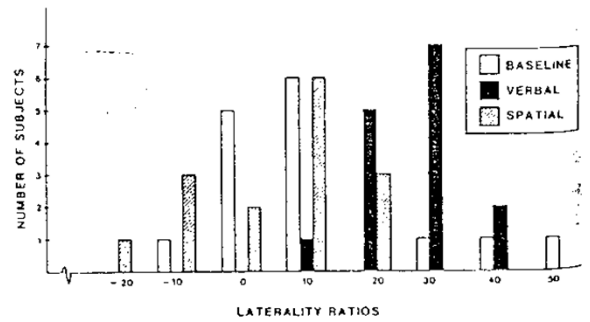

Controlling for EMG contributions

- Spydell & Sheer (1982)
 - used similar tasks and found similar results
 - using conservative controls for muscle artifact

Alj, 1982 Alpha, Beta II, 40 Hz EEG, and 40 Hz EMG Activity 423

TABLE 1
Median changes in rate scores

Problems	Alpha		Beta II		40 Hz Total		40 Hz EMG		40 Hz EMG	
	Left	Right	Left	Right	Left	Right	Left	Right	Left	Right
Verbal	-36.7*	-52.4*	-20.1*	-20.2*	1.0*	0.1	1.2*	0.1	8.4*	10.6*
Rotation	-36.7*	-37.6*	-15.3*	-15.3*	0.7	1.0*	0.4	0.9*	13.9*	8.9*

*p < .05.

Spydell and Sheer Vol.

TABLE 3
Spearman rank-order correlations between various 40 Hz activity measures

40 Hz Measures	Verbal		Rotationless		Rotational	
	Left	Right	Left	Right	Left	Right
40 Hz EEG	.74*	.68*	.94*	.94*	.78*	.78*
40 Hz EMG	.27	.28	.39	.05	.27	.35

*p < .05.

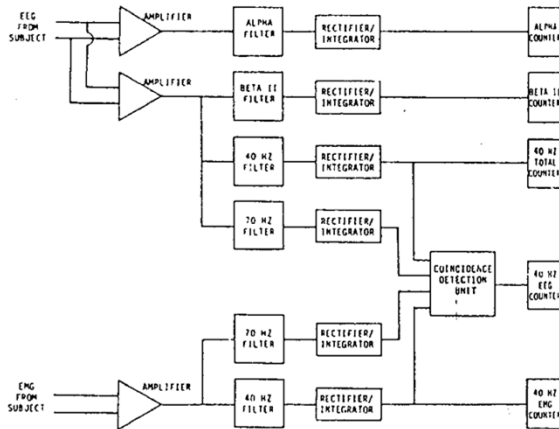

Individual Differences

- Spydell & Sheer (1983), Alzheimers
 - controls showed task related changes in EEG with appropriate lateralization
 - Alz did not
- Schnyer & Allen (1995)
 - Most highly hypnotizable subjects showed enhanced 40 hz activity

So this is exciting, why didn't this work take off immediately?

- The EMG concern
- The concern is likely over-rated (recall **Table 3**)
- Sheer died
- But not all is lost, as there is renewed interest...

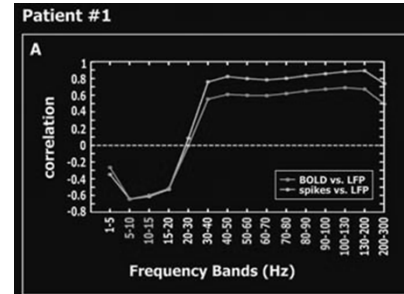

Mukamel et al *Science* 2005
recorded single unit activity and local field potentials in auditory cortex of two neurosurgical patients and compared them with the fMRI signals of 11 healthy subjects during presentation of an identical movie segment. The predicted fMRI signals derived from single units and the measured fMRI signals from auditory cortex showed a highly significant correlation.

Singer (1993)

- Revitalized interest in the field

The Binding Problem

- Potentially infinite number of things and ideas that we may attempt to represent within the CNS
 - Cells code for limited sets of features,
 - These must somehow be integrated
 - -- the so-called binding problem
- If there exists a cell for a unique contribution of attributes, then convergent information from many cells could converge on such a cell
 - But there are a finite # of cells and interconnections
- And even the billions and billions of cells we have cannot conceivably handle the diversity of representations

The Functional Perspective -- as yet merely a theory

- There is no site of integration
 - Integration is achieved through simultaneous activation of an assembly of neurons distributed across a wide variety of cortical areas
 - Neurons in such assemblies must be able to adaptively identify with other neurons within the assembly while remaining distinct from other neurons in other assemblies
 - This association with other neurons is through a temporal code of firing (Synchronicity)
 - This even allows for the possibility that a single neuron could be part of two active assemblies (via a multitasking procedure)

Implications

- Also allows for the possibility that there exists no direct neuronal connection between neurons within an assembly
 - merely the fact that they are simultaneously activated that makes the unified experience of the object possible
- Yet what can synchronize these oscillations?

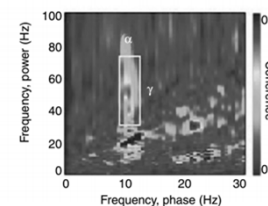

Jensen et al, *TICS*, 2012

Implications – Alpha as a synchronization mechanism

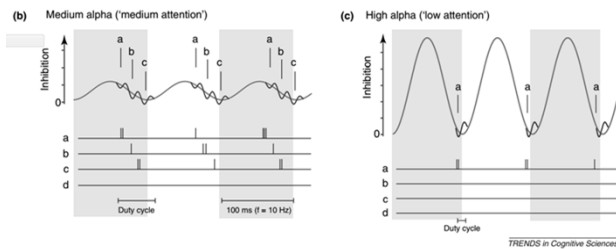

Jensen et al, *TICS*, 2012

Functional Role of Gamma Synchronization

- Feedforward coincidence detection
 - To summate effectively, signals must arrive at post-synaptic neuron from multiple sources within msec of each other (else decay)
 - Gamma-band synchronization can lead to temporal focusing of inputs from multiple and distributed pre-synaptic neurons
- Rhythmic Input Gain Modulation
 - Excitatory input is most effective when it arrives out of phase with inhibitory input and vice versa
 - Allows for precision and efficiency of signal transmission (or inhibition)

Fries, 2009

Implications

- This view is a dynamic view
 - depends on experience
 - can change with experience
- Synchronously activated units more likely to become enhanced and part of an assembly that will subsequently become synchronously activated
- Singer concludes:
 - Points out the problem of looking for synchronous activation on the micro level, suggesting that a return to the EEG literature looking for task-dependent synchronization in the gamma (aka 40 Hz) band!
- Forty-Hz may indeed make a comeback!
 - “Forty” = $40 \pm$ some range
 - Gamma! (Stay tuned during advanced topics)

The Event-Related Potential (aka the ERP)

Overview

Event-related potentials are patterned voltage changes embedded in the ongoing EEG that reflect a process in response to a particular event: e.g., a visual or auditory stimulus, a response, an internal event

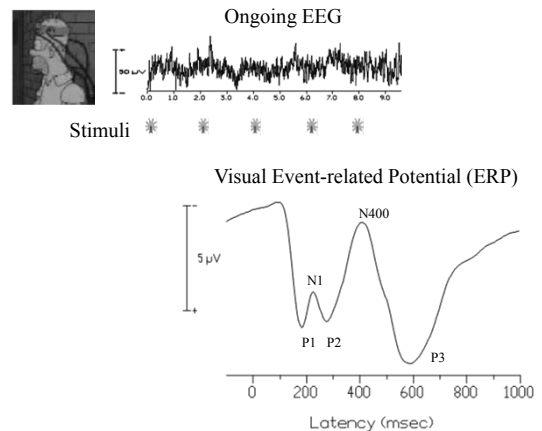

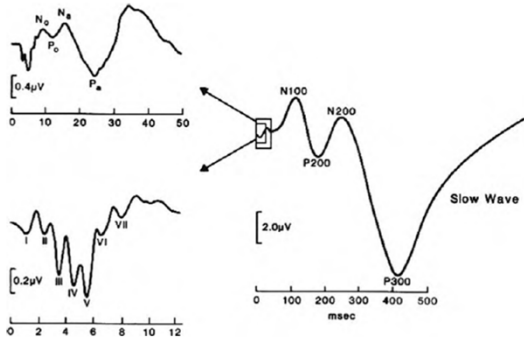
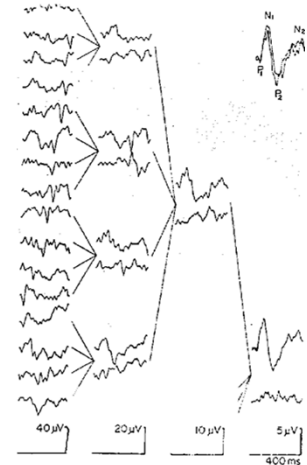

Figure 4.2. A schematic representation of ERP components elicited by auditory, infrequent target stimuli. The three panels represent three different voltage × time functions: the left bottom panel shows the very early sensory components (with a latency of less than 10 ms); the left top panel shows the middle latency sensory components (with a latency of between 10 and 50 ms); and the right panel shows late components (latency exceeding 50 ms). Note the different voltage and time scales used in the three panels, as well as the different nomenclatures used to label the peaks (components). (Adapted with permission of the author from Donchin, 1979, with kind permission of Springer Science and Business media.)

Time-locked activity and extraction by averaging



The Classic View:

Time-locked activity and extraction by signal averaging

- Ongoing activity reflects "noise"
- Activity that reflects processing of a given stimulus "signal"
- The signal-related activity can be extracted because it is **time-locked** to the presentation of the stimulus
- Signal Averaging is most common method of extracting the signal
 - Sample EEG for ~1 second after each stimulus presentation & average together across like stimuli
 - Time-locked signal emerges; noise averages to zero
 - Signal to noise ratio increases as a function of the **square root** of the number of trials in the average

What does the ERP reflect?

- May reflect sensory, motor, **and/or** cognitive events in the brain
- Reflect the synchronous and phase-locked activities of large neuronal populations engaged in information processing

Component is a "bump" or "trough"

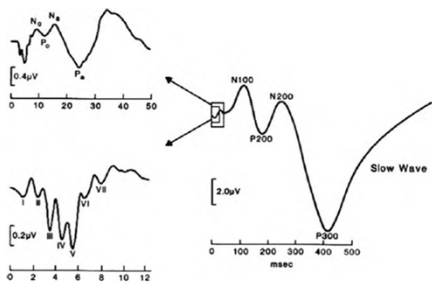

Figure 4.2. A schematic representation of ERP components elicited by auditory, infrequent target stimuli. The three panels represent three different voltage × time functions: the left bottom panel shows the very early sensory components (with a latency of less than 10 ms); the left top panel shows the middle latency sensory components (with a latency of between 10 and 50 ms); and the right panel shows late components (latency exceeding 50 ms). Note the different voltage and time scales used in the three panels, as well as the different nomenclatures used to label the peaks (components). (Adapted with permission of the author from Donchin, 1979, with kind permission of Springer Science and Business media.)

Making Meaning from the bumps

Pores o'er the Cranial map with learned eyes,
Each rising hill and bumpy knoll decies
Here secret fires, and there deep mines of sense
His touch detects beneath each prominence.



Nomenclature & Quantifying

- Most commonly label peaks and troughs by polarity (P or N) and latency at active recording site
- Quantifying
 - Amplitude
 - Latency
 - Area
 - “String” measure
- Fancy stuff to be discussed in “advanced” topics

Component is a "bump" or "trough"

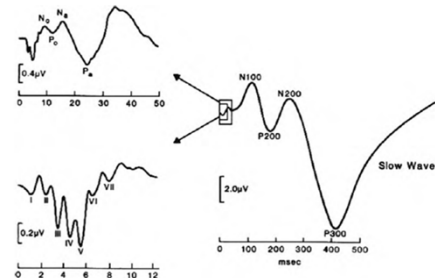

Figure 4.2. A schematic representation of ERP components elicited by auditory, infrequent target stimuli. The three panels represent three different voltage \times time functions: the left bottom panel shows the very early sensory components (with a latency of less than 10 ms); the left top panel shows the middle latency sensory components (with a latency of between 10 and 50 ms); and the right panel shows late components (latency exceeding 50 ms). Note the different voltage and time scales used in the three panels, as well as the different nomenclatures used to label the peaks (components). (Adapted with permission of the author from Donchin, 1979, with kind permission of Springer Science and Business Media.)

Early Components

- Waves I-VI represent evoked activity in auditory pathways and nuclei of the brainstem
- Early components <60-100 msec
 - occur in **obligatory** fashion
 - are called **Exogenous** = determined "outside" organism
- Even subtle deviations in appearance may be indicative of pathology

Later ERP components

- Highly sensitive to changes in
 - State of organism
 - Meaning of stimulus (NOT physical characteristics)
 - Information processing demands of task
- Therefore termed **Endogenous** = determined “within” organism

Not all components fit neatly into exogenous or endogenous categories

- Both Obligatory but modulated by psychological factors
- “Mesogenous”

Defining Components:
aka how do I know one when I see one?

- By positive and negative peaks at various latencies and scalp locations
- By functional associations, covarying across subjects, conditions, or scalp locations in response to experimental manipulations
- By neuronal structures that plausibly give rise to them

Evoked Vs Emitted ERP's

- Evoked are most commonly studied: occur in response to a physical stimulus
- Emitted potentials occur in absence of a physical stimulus (e.g., omission of item in sequence)
- Evoked can have both exogenous and endogenous components; emitted usually have only endogenous

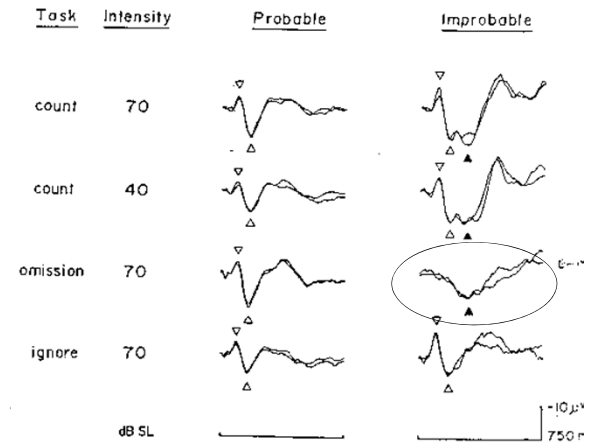

Comparison to other "windows on the brain"

- Very precise temporal resolution

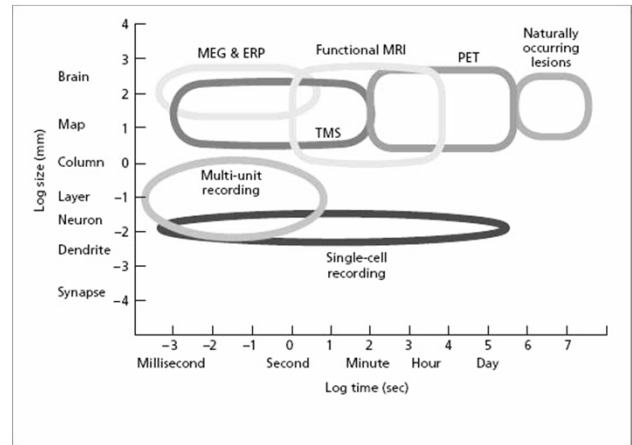

Comparison to other "windows on the brain"

- Very precise temporal resolution
- Spatial localization is more difficult
 - At the surface, activity of many functional synaptic units recorded
 - ERP's generated only by groups of cells that are synchronously activated in a geometrically organized manner

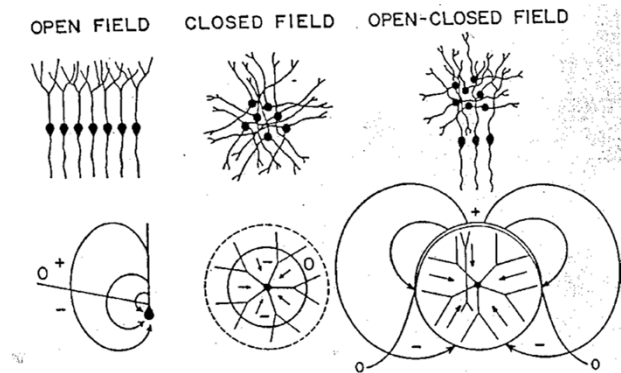

After Lorente de Nó, 1947

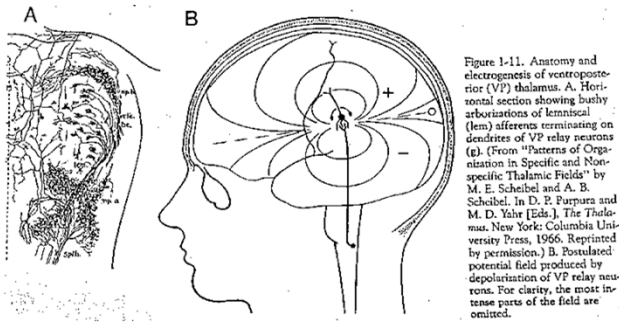

Comparison to other "windows on the brain"

- Very precise temporal resolution
- Spatial localization is more difficult
 - At the surface, activity of many functional synaptic units recorded
 - ERP's generated only by groups of cells that are synchronously activated in a geometrically organized manner
 - Synchronous activation may occur in one or more than one location
 - Monopolar recording technique most often used
 - Yet localization is not impossible in conjunction with other techniques

Caveat Emptor

- DO NOT interpret scalp distribution of ERP's as reflect cortical specialization
- Also, DO NOT interpret area of maximum amplitude to suggest that generator lies underneath

Correlate Vs substrate (AGAIN)

- Late ERP components should not be taken to indicate the existence of a neurological substrate of cognitive processing
- Rather should be considered a correlate
- Constructs in search of validation; Process of validation:
 - Determine antecedent conditions under which the ERP component appears and also magnitude and latency of ERP component
 - Develop hypotheses concerning functional significance of the "subroutine" underlying the ERP component
 - Predict consequences of subroutine--validate empirically

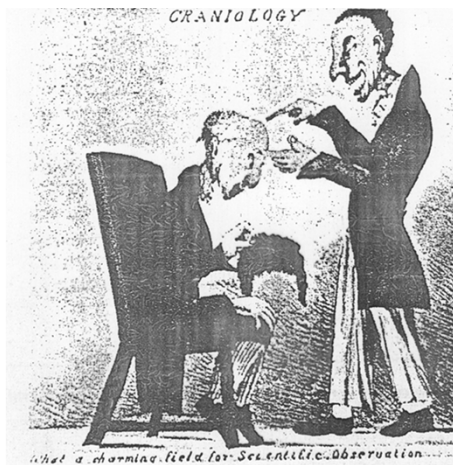

Basic Signal Processing

Paradigms and acquisition

- Precise temporal control over stimulus presentation necessary
 - Requires discrete stimuli or responses
- Individual stimuli are presented numerous times; ERP's generally do not habituate, unlike peripheral measures
- Concurrent with each stimulus, a signal/pulse must be sent to the A/D converter to indicate time of stimulus onset
- A/D converter and sampling
 - sampling either as pulse received, or it may be continuously monitored
 - several pre-onset samples (to provide a baseline for comparison);
 - **epoch** length
- Epochs for like stimuli averaged together to create ERP for that set of stimuli

Assumptions of Averaging methods

- Signal and noise (in each epoch) sum linearly together to produce the recorded waveform for each epoch (not some peculiar interaction)
- The evoked signal waveshape attributable **solely** to the stimulus is the same for each presentation
- The noise contributions can be considered to constitute statistically independent samples of a random process

Demo of Averaging

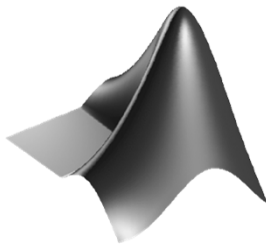

Filtering and its influence on the ERP

- Despite many trials and averaging, some noise may remain in the averaged waveform
- If you are only interested in later & slower components, then a low-pass filter may be of interest

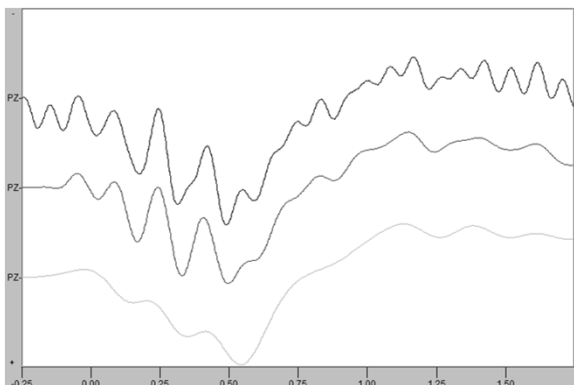

Same ERP filtered with 12.5 (black), 8 (red), and 5 (lime) Hz Low Pass FIR Filter

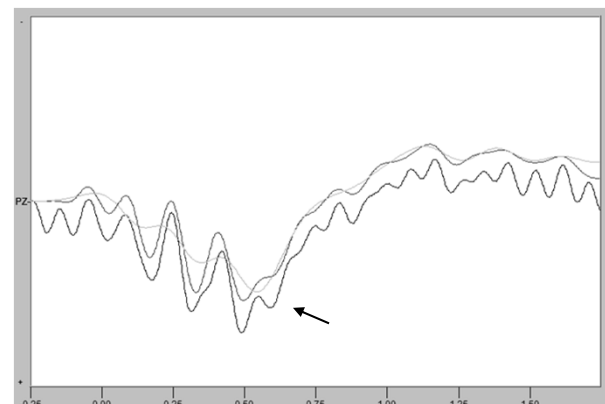

Same ERPs overlaid; note amplitude attenuation in P3 amplitude with stricter filters