

*A bit more on
Frequency-domain EEG*

and then...

The Event-related Brain Potential (Part 1)

Announcements 4/5/21

- Paper/Proposal Guidelines available on course webpage (link in D2L too)
 - Two paragraph prospectus due (on D2L “Research Prospectus”) no later than Monday April 19
- Lab: See the videos for signal processing; you will receive compiled dataset from TA
- Class Feedback and Q&A

Next few slides courtesy of Dr. Ryan

Positron emission tomography

Cyclotron creates an isotope, where extra protons are added to the nucleus, creating instability.

Isotope is connected to the compound of interest (such as oxygen or glucose) and injected.

As the molecule decays, it emits a positron which is annihilated when it collides with an electron.

Annihilation event releases energy (photons) that can be measured with detectors.

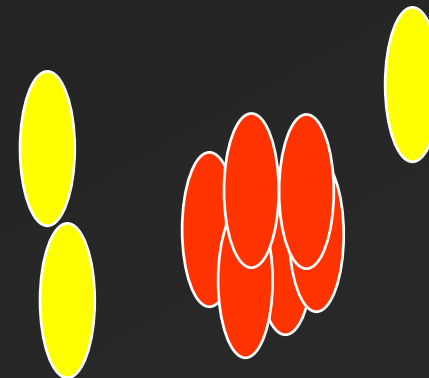

A cyclotron is used to create the isotope, adding additional protons to molecules of interest, such as oxygen, glucose, etc.





The radioactive isotope is injected into the subject, and is taken up by the brain into metabolically active regions. Detectors measure events as the isotope decays.

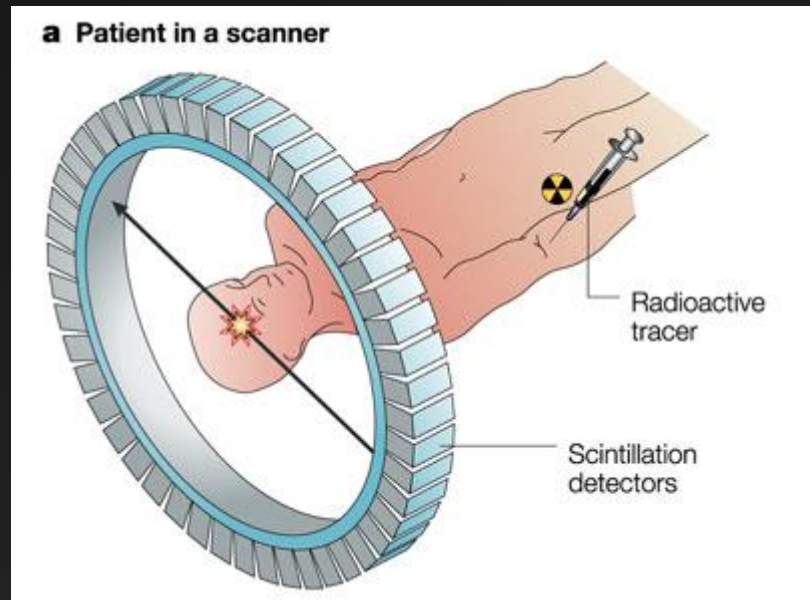

Annihilation: Decay via positron emission

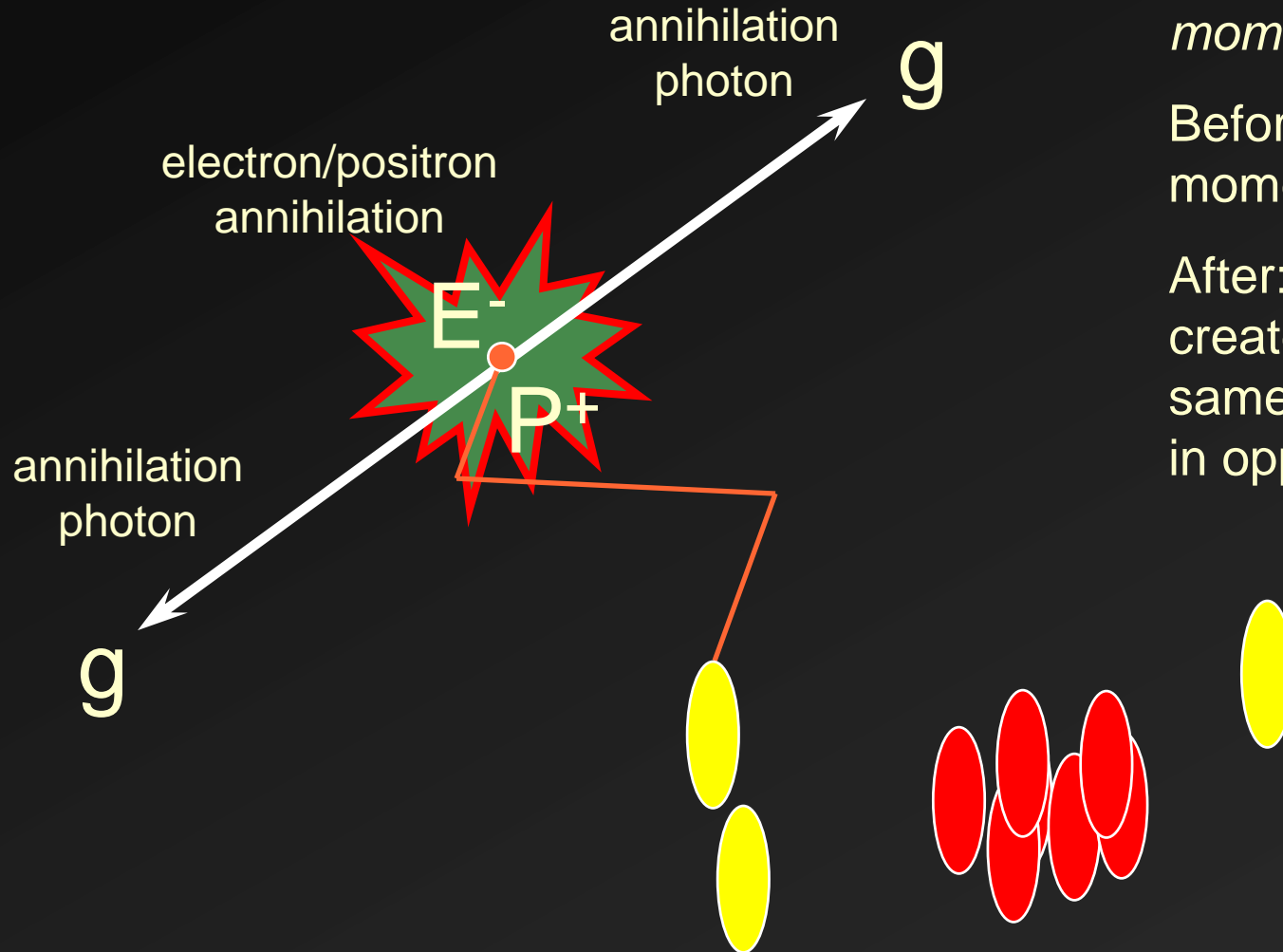

Conservation of momentum:

Before: system at rest; momentum ~ 0

After: two photons created; must have same energy and travel in opposite direction.

Emits gamma ray (two photons), travelling a path 180 degrees from the site of annihilation.

Sufficient energy in gamma rays to increase probability of passing out of brain without attenuation

Scatter (how far the positron moves away from molecule) is 2 mm or less.

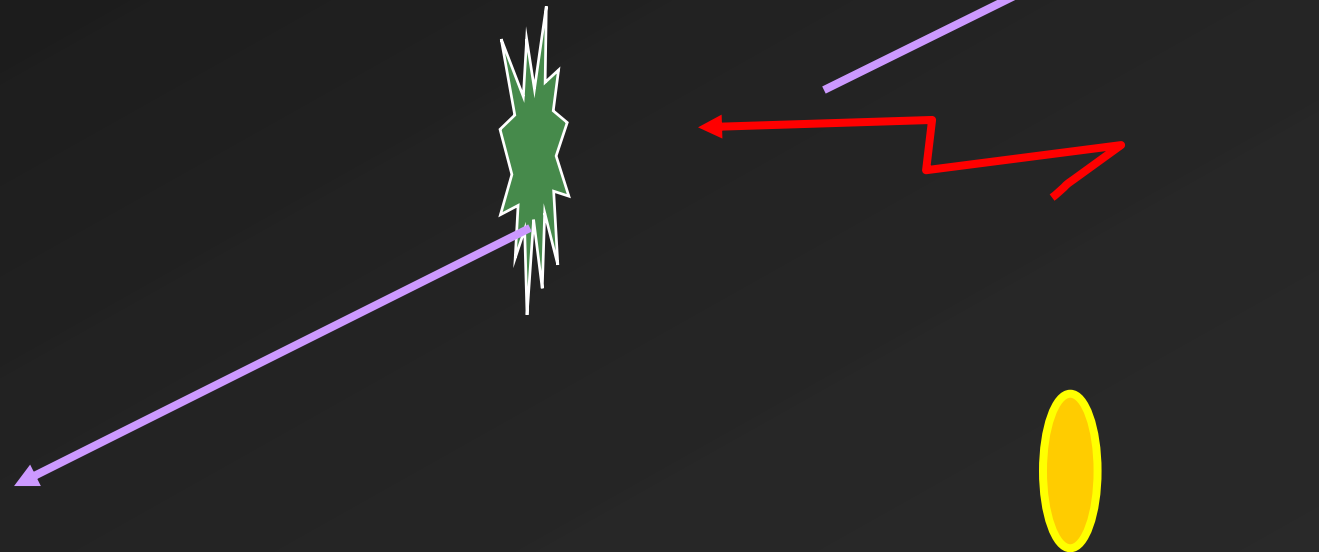

Coincident detection

Scintillating crystal detectors in circumferential arrays, measure coincident events only.

Essentially counts coincident events, assumes a line of events (180 degrees).

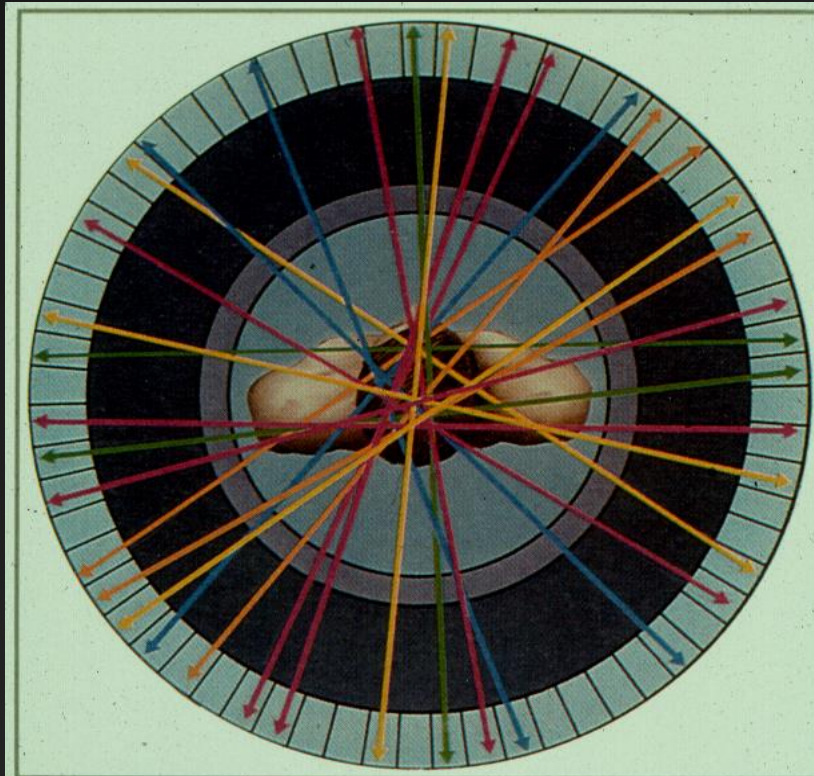

6. The multiple LORs through multiple points.

Tomographic problem, reconstruction using back-projection

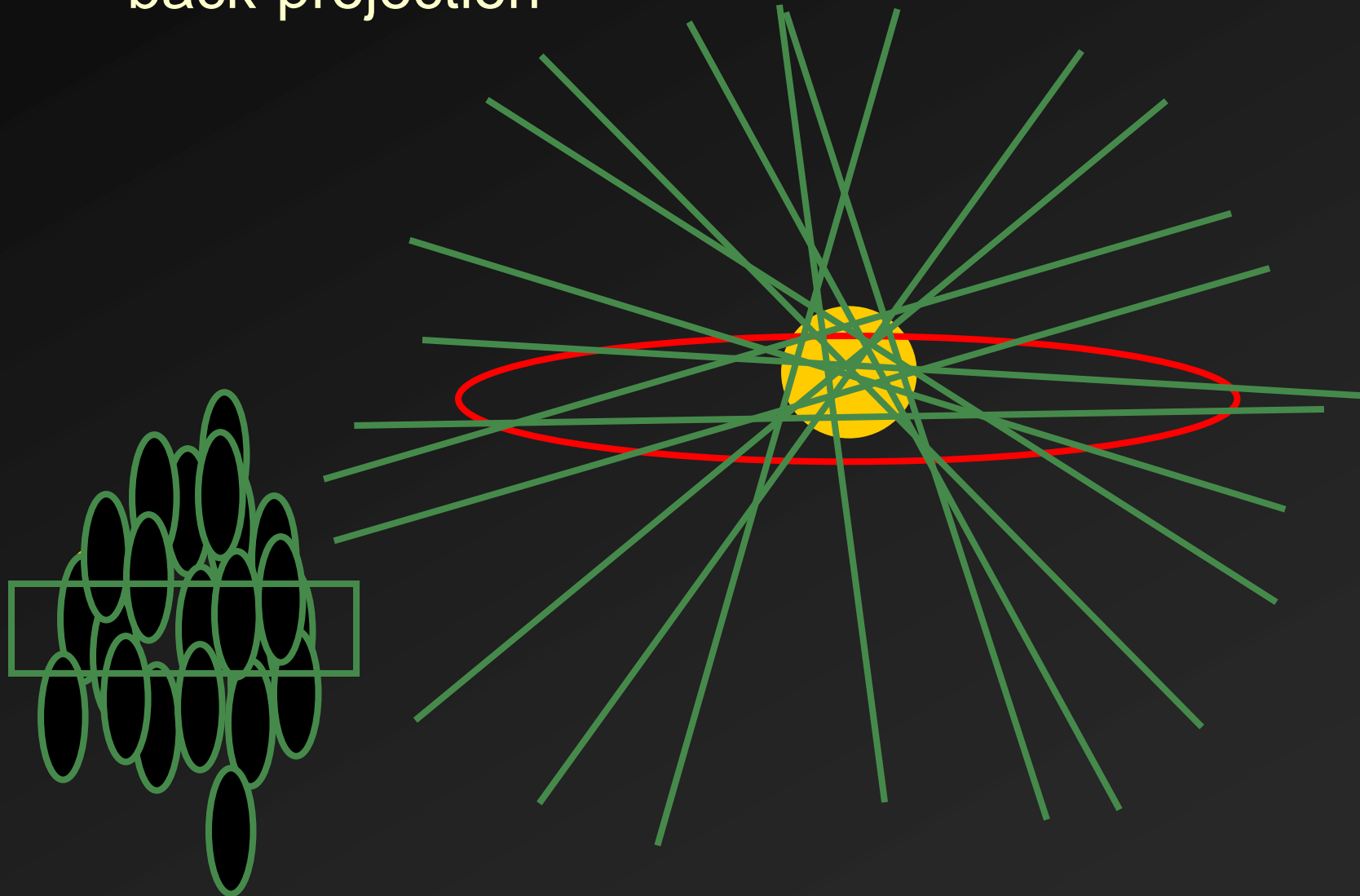

PET tracers:

1. Oxygen - HL is 1.5 mins.

[15O]-labeled water and oxygen used in quantification of oxygen consumption.

2. Carbon - HL is 10.0 mins.

[11C]-labeled cocaine used to measure responses of dopamine D2 receptors during acute and chronic drug use.

3. Fluorine - HL is 109 mins.

[18F]-2-deoxyglucose (FDG) most often used in activation studies. Also used to label L-Dopa and fluoroethylspiperone which bind to D2 dopamine receptors.

End of slides from Dr. Ryan

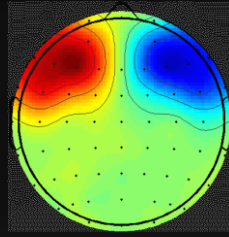

$\ln(R) - \ln(L)$ Alpha

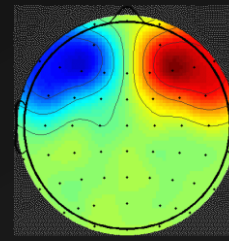

- Positive Affect and Mood
- Behavioral Engagement
- Approach Motivation (including Anger)
- High Behavioral Activation
- Depression and Risk

- Negative Affect and Mood
- Behavioral Disengagement
- Withdrawal Motivation
- Low Behavioral Activation
- Well-being and resilience

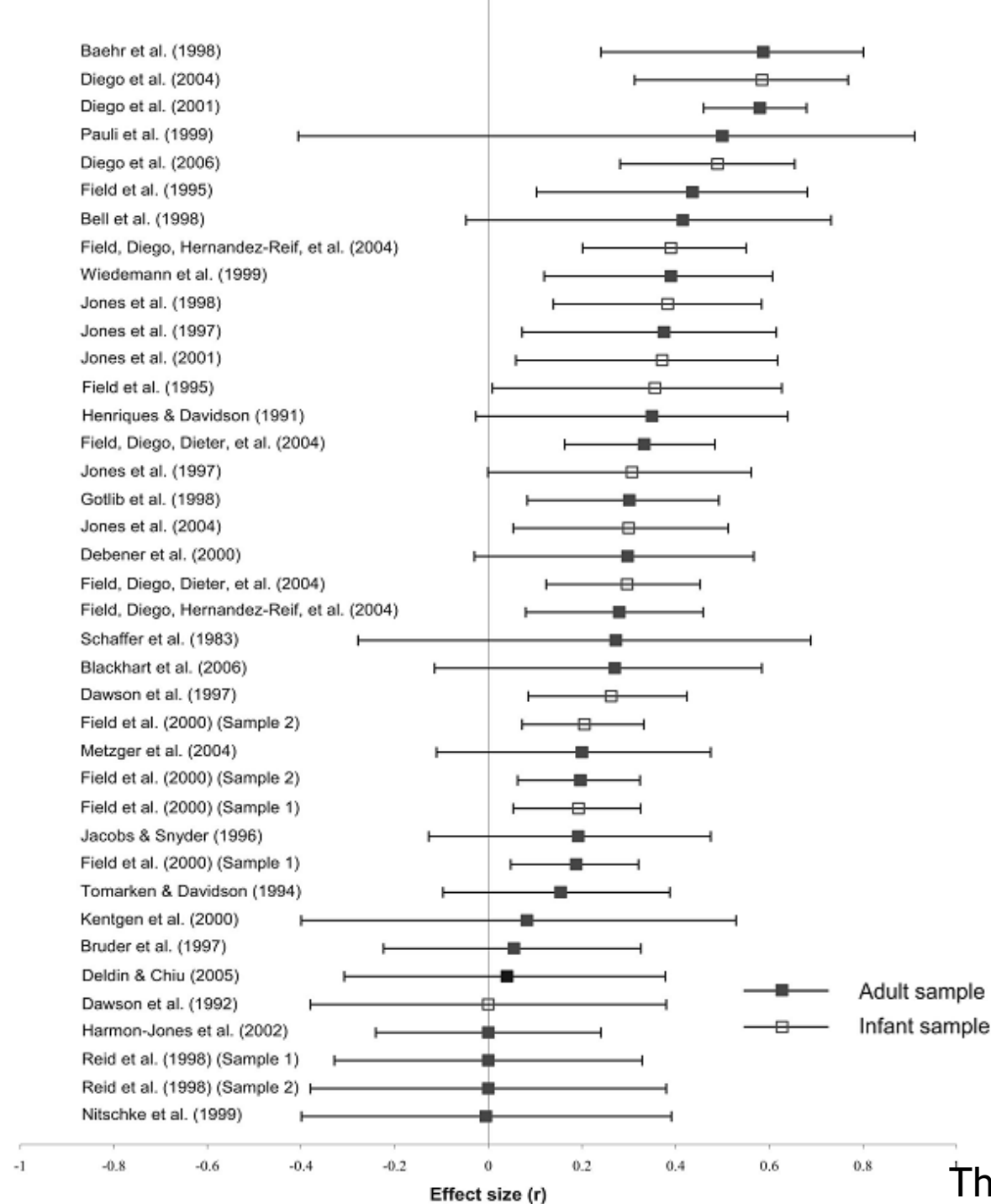

Mean Effect Sizes

Adults $d=0.54$

Infants $d=0.61$

Moderators

Reference

Recording length

Co-morbidity

Publication Bias

↑ Effect Size

Can't account for full effects

Reference Effects

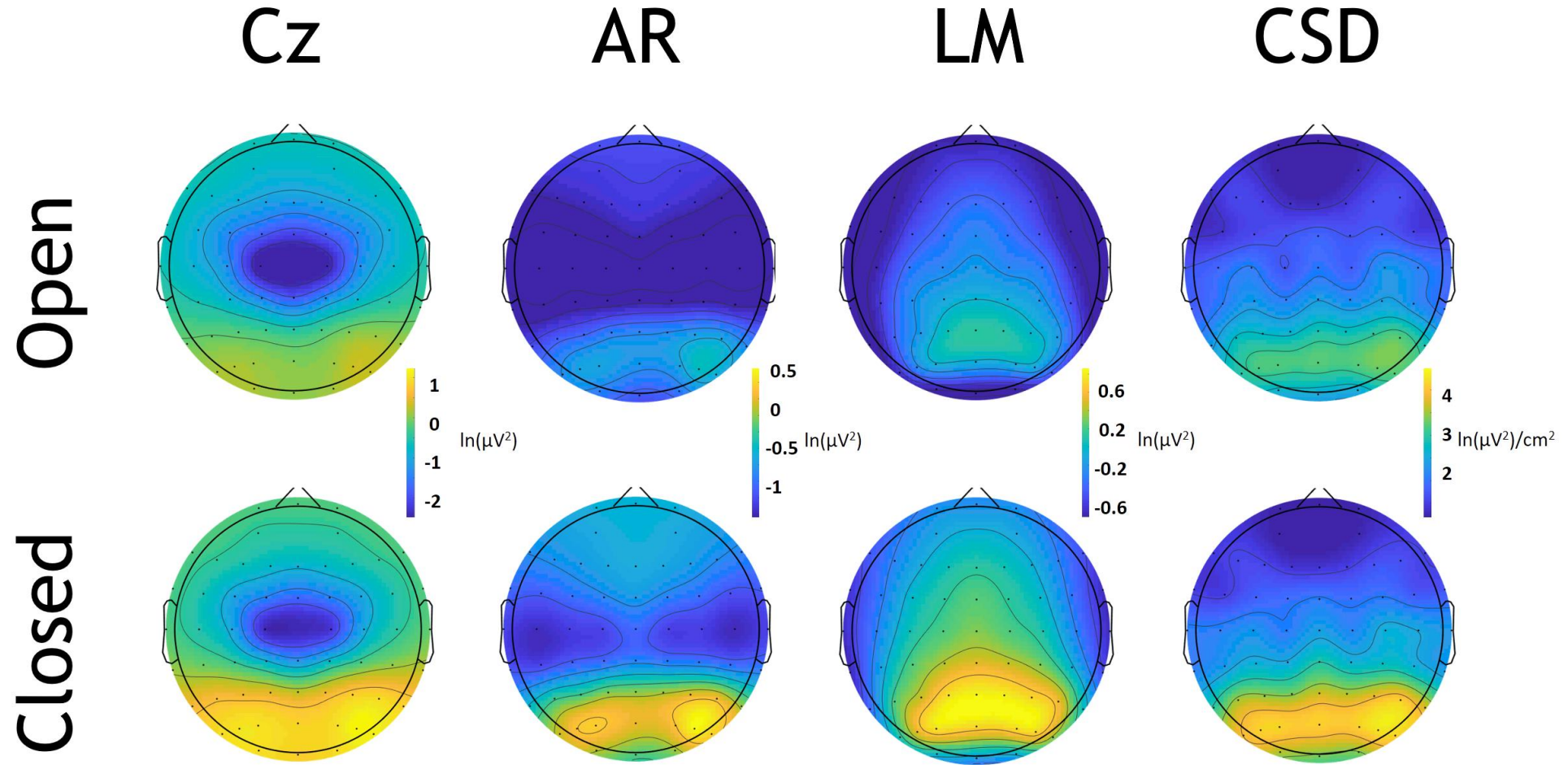

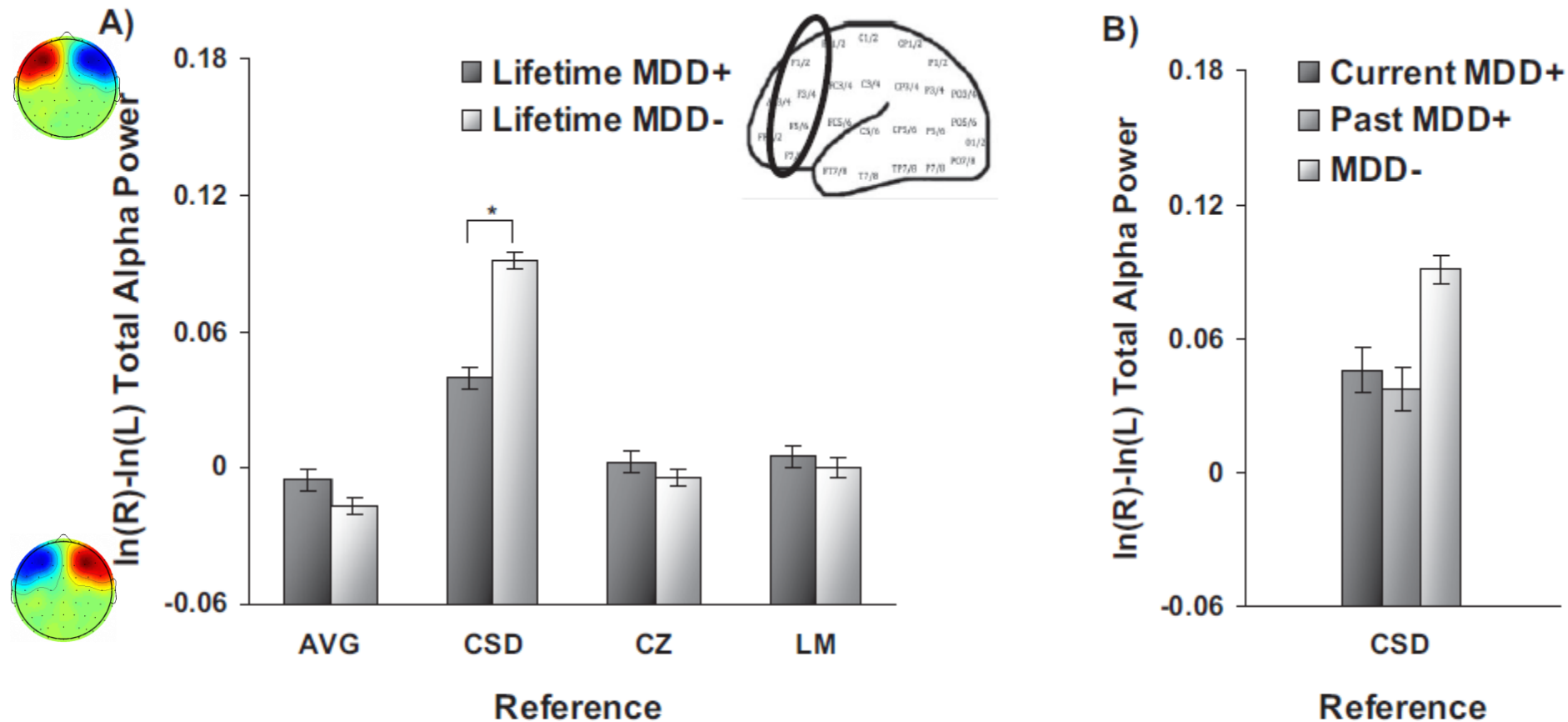

Figure 2. Panel A shows frontal alpha asymmetry scores (8–13 Hz at F2–F1, F4–F3, F6–F5, F8–F7) by lifetime MDD status for each reference montage across all four frontal regions depicted on the head insert. Error bars reflect standard error. Panel B shows results of a follow-up assessment indicating that the relationship of lifetime MDD status to CSD-referenced asymmetry is not solely accounted for by current MDD status. The y-axis is $\ln \mu V^2$ for AVG, Cz, and LM references, and $\ln \mu V^2/cm^2$ for CSD referenced data. MDD = major depressive disorder; AVG = average; CSD = current source density; CZ = Cz; LM = linked mastoid.

STICK WITH CSD...

Interim Synopsis: Endophenotype Desiderata

Gottesman & Shields, 1972; Gottesman & Gould, 2003; Iacono, 1998

- ☑ Specificity: Associated with disorder
- ☑ Heritability
- ☑ State-independence: Primarily trait
- ☑ Familial Association: Seen in unaffected family members at rates higher than general population
- ◄ Predictive Power: predicts future disorder in unaffected individuals

Prospective Pilot Data

- ◆ Assessed never depressed (MDD-) individuals ~1 year after EEG
- ◆ Obtained 54 of 163 (representative)
- ◆ Completed BDI based on “worst month”
- ◆ BDI worst month residualized on BDI at EEG assessment
- ◆ Can EEG predict this worst month BDI score?

Prospective Pilot Data

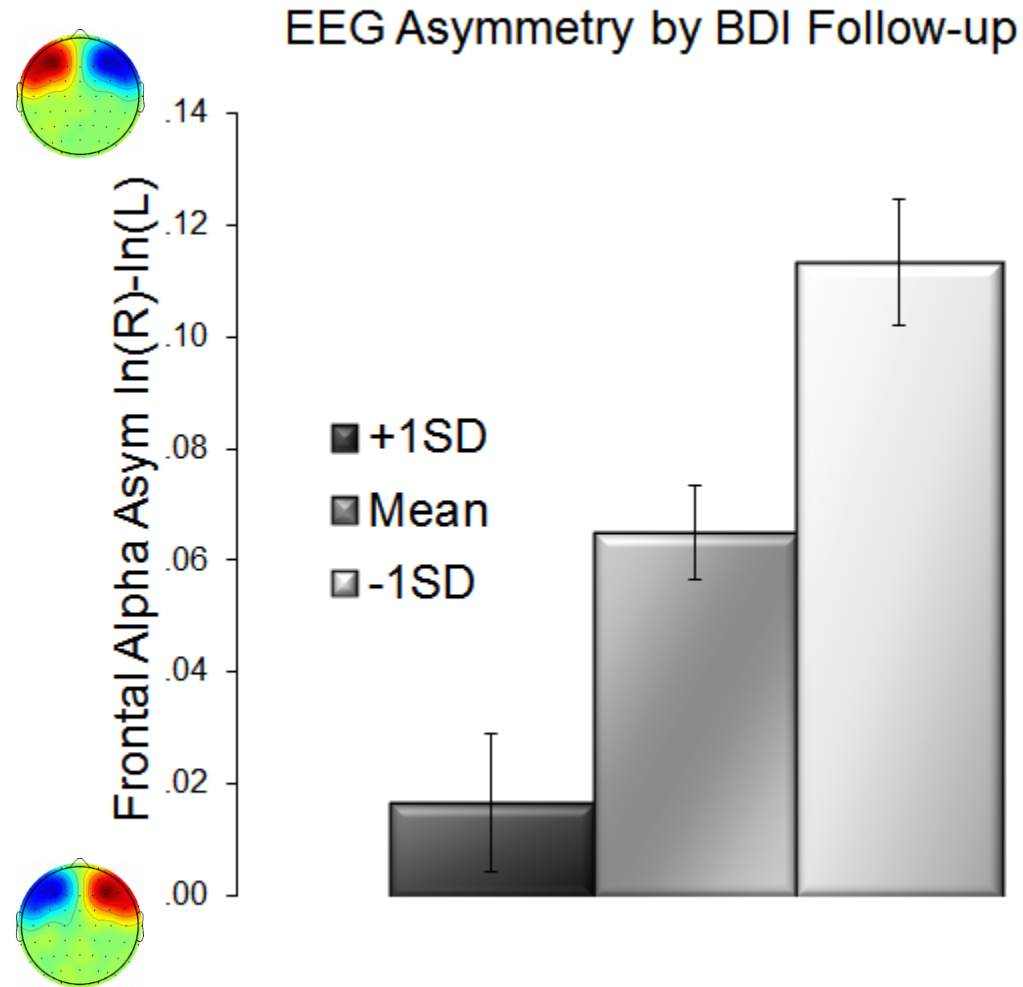

See also Nusslock et al.,
J Abnormal Psychology,
2011

Prospective Pilot Data: a wrinkle

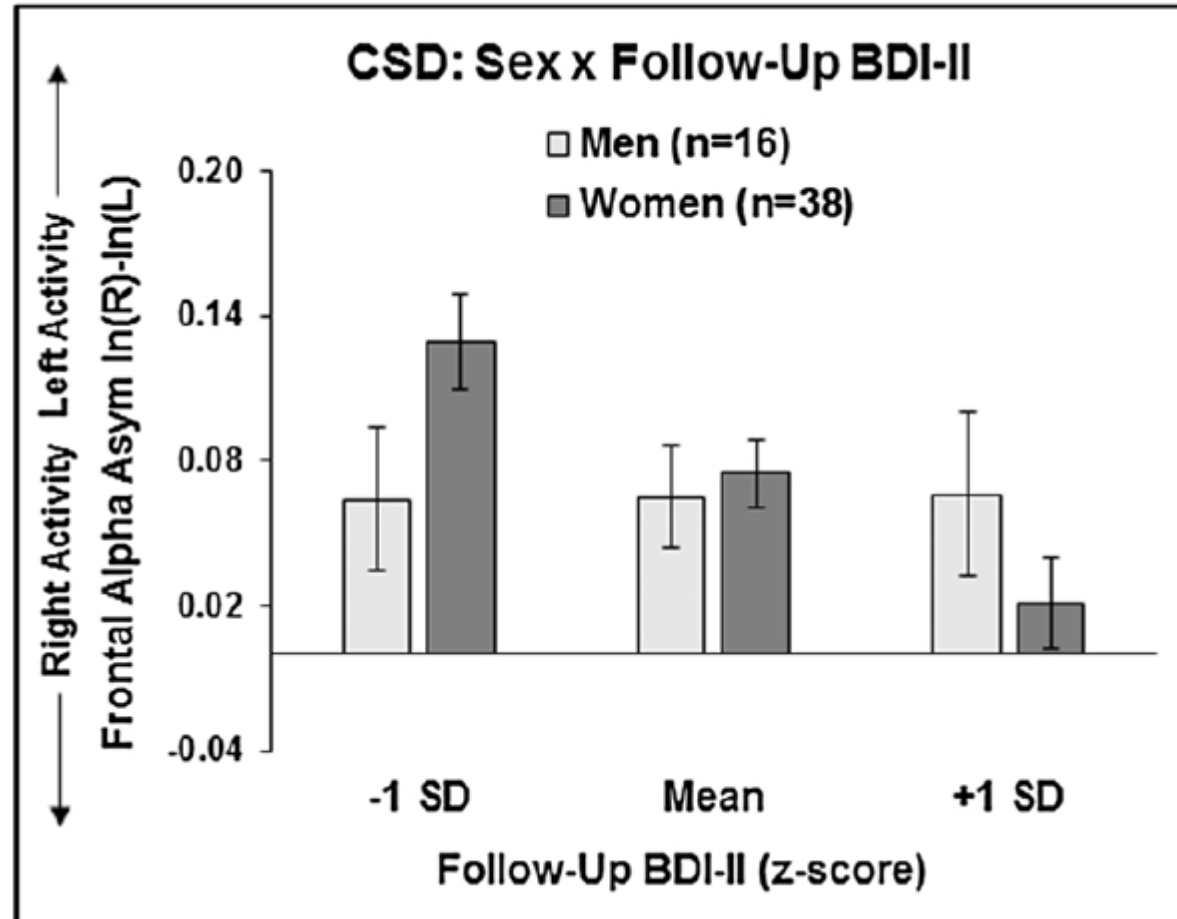

Thus

- ◆ Frontal EEG asymmetry has promise as a risk indicator for MDD and other internalizing disorders
- ◆ Need:
 - ◆ Large-scale prospective study
 - ◆ Links to underlying neural systems

TIME AND SPACE

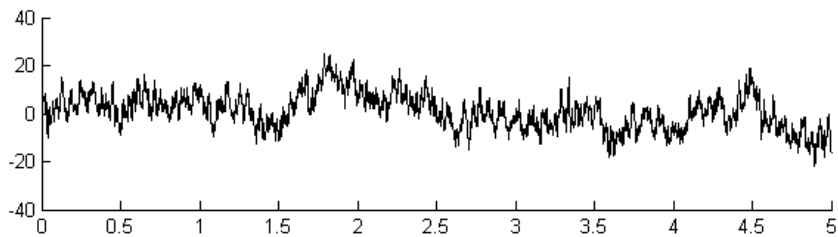
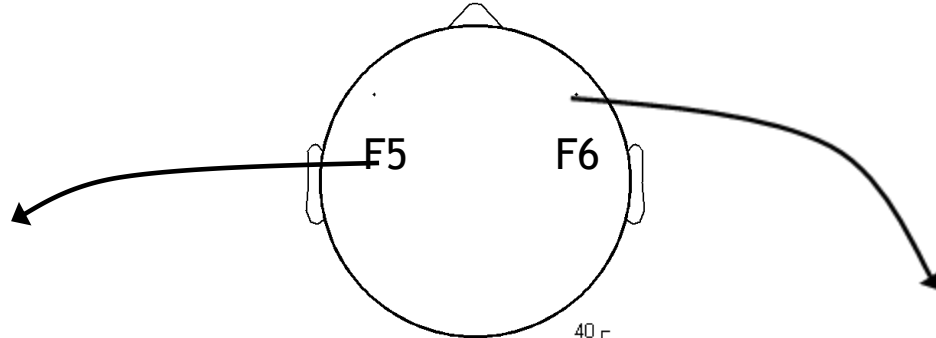

Raw

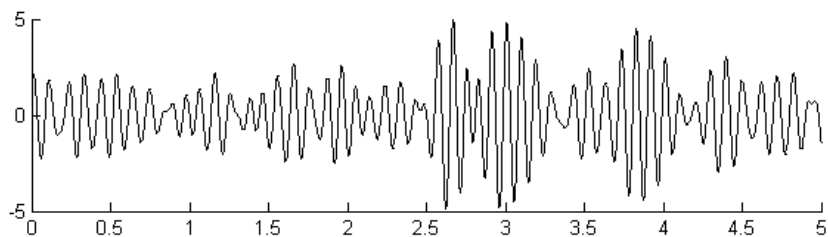
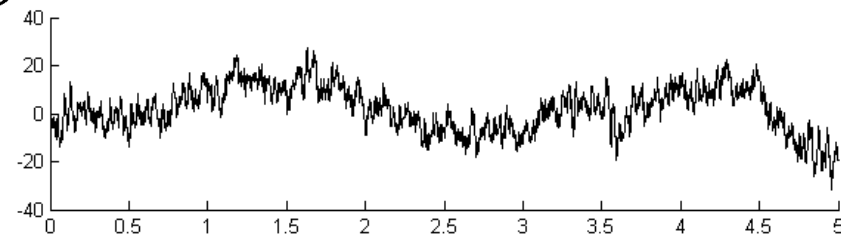

8-13 Hz
Filtered

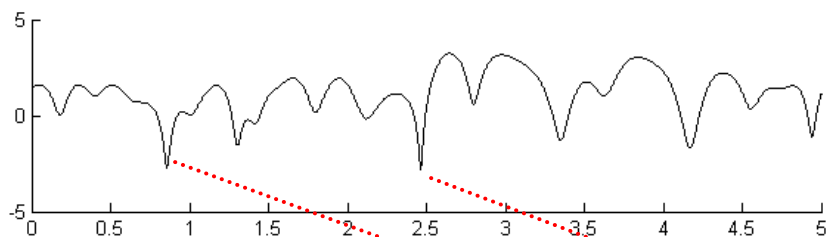
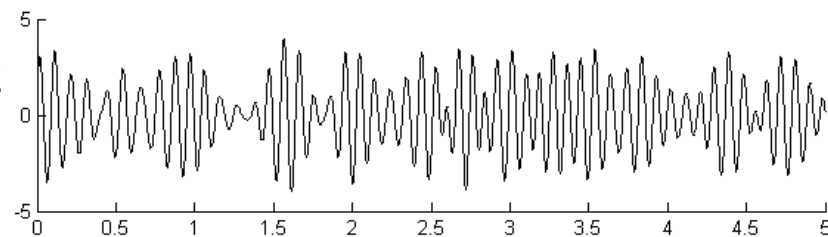

Ln
Power

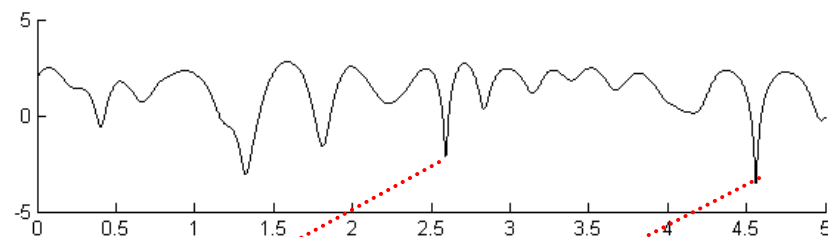

1%

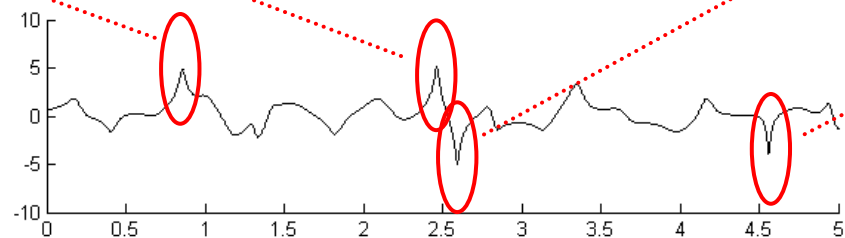

Continuous R-L
Difference

Relationship of Peri-Burst Alpha Asymmetry at F6-F5 with Conventional FFT-Derived Alpha Asymmetry across the scalp

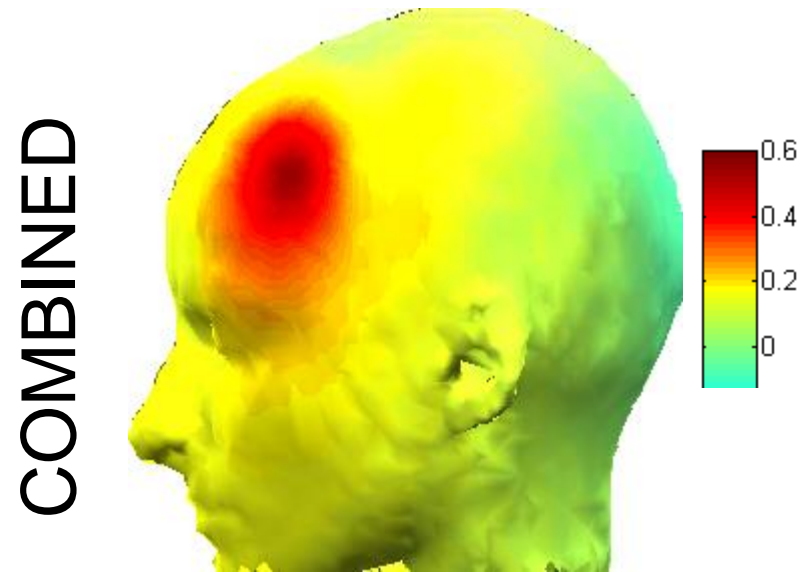
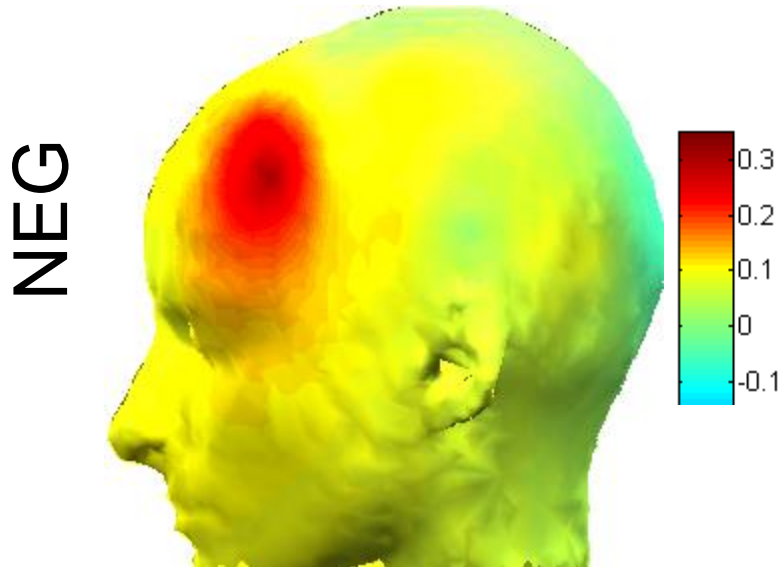
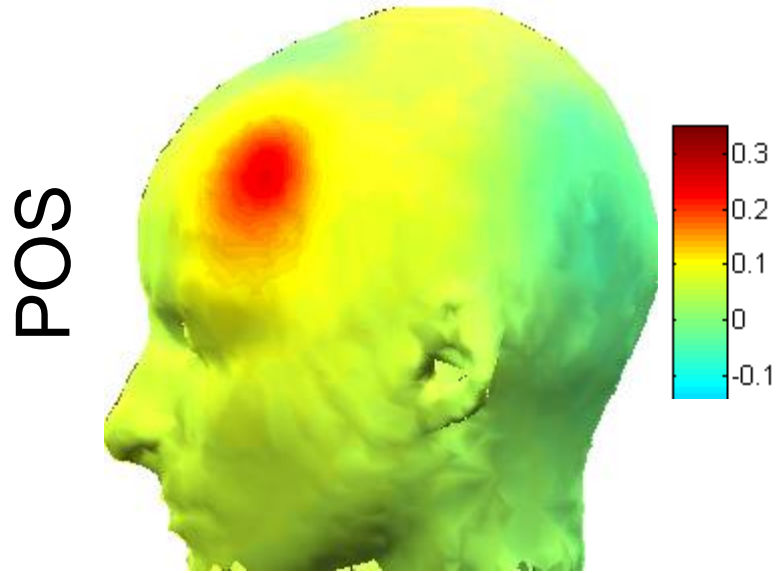

$r^2 = .42 !$

(1%)

Conventional Frontal EEG Alpha Asymmetry by MDD status

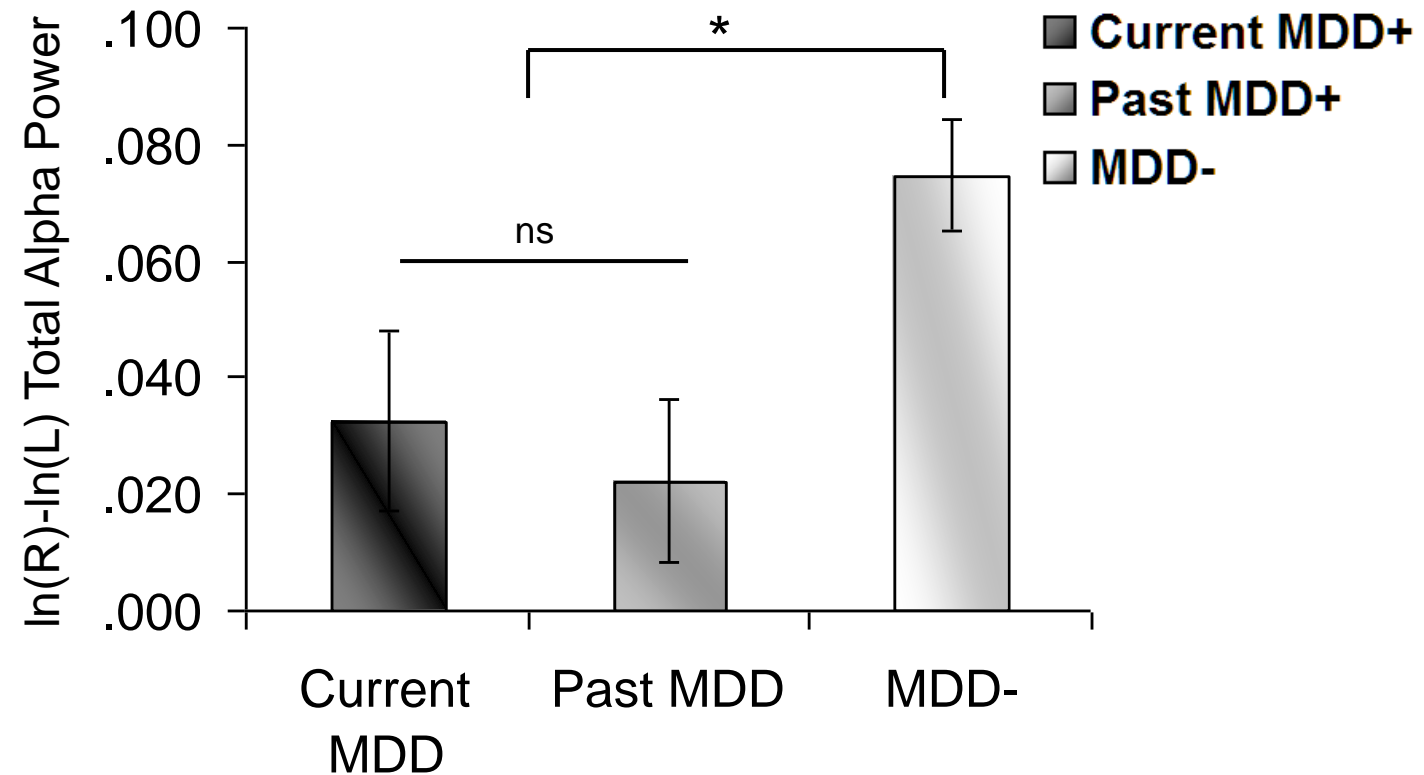

Peri-burst Frontal EEG Alpha Power Asymmetry by MDD status

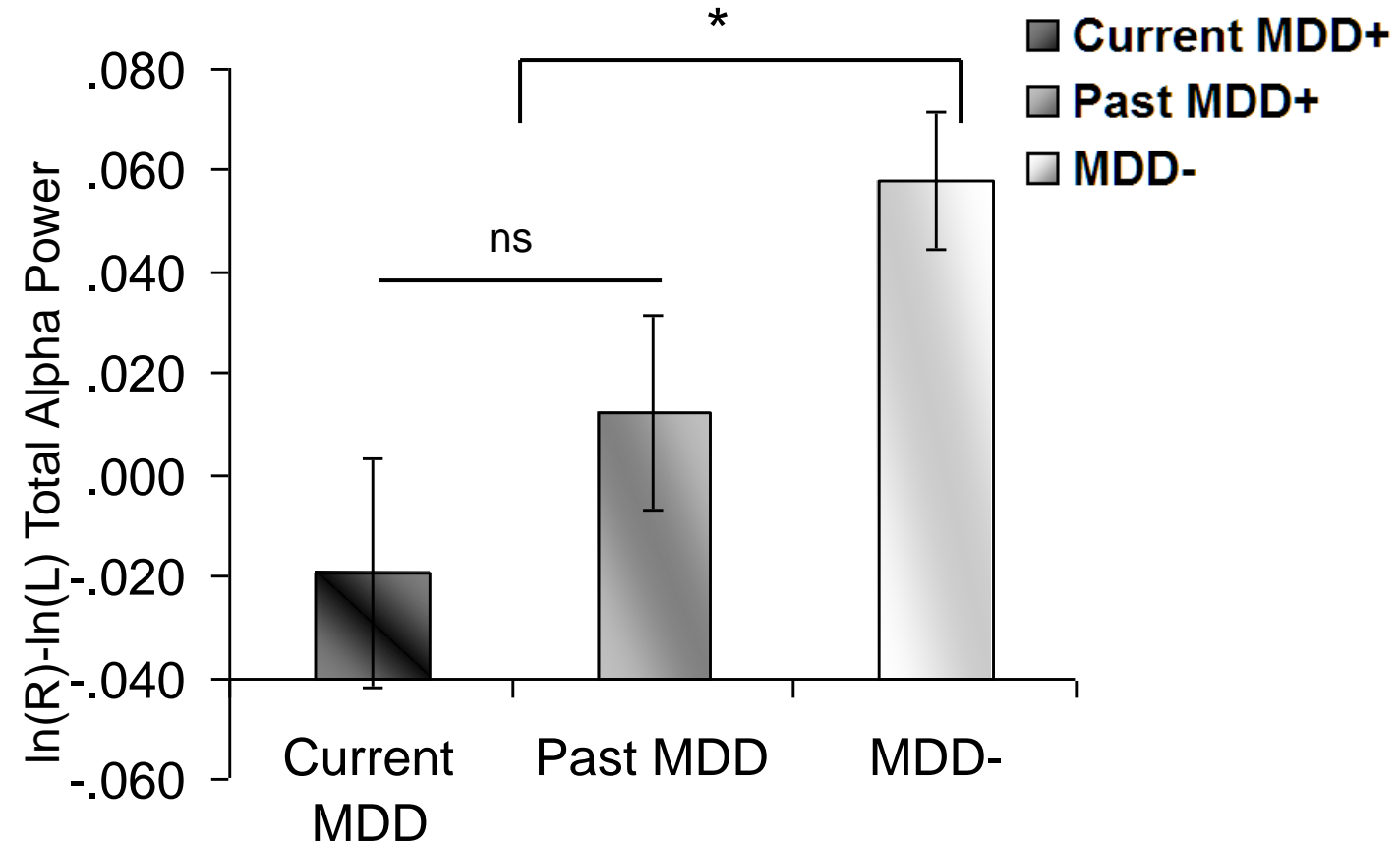

(A) Positive bursts

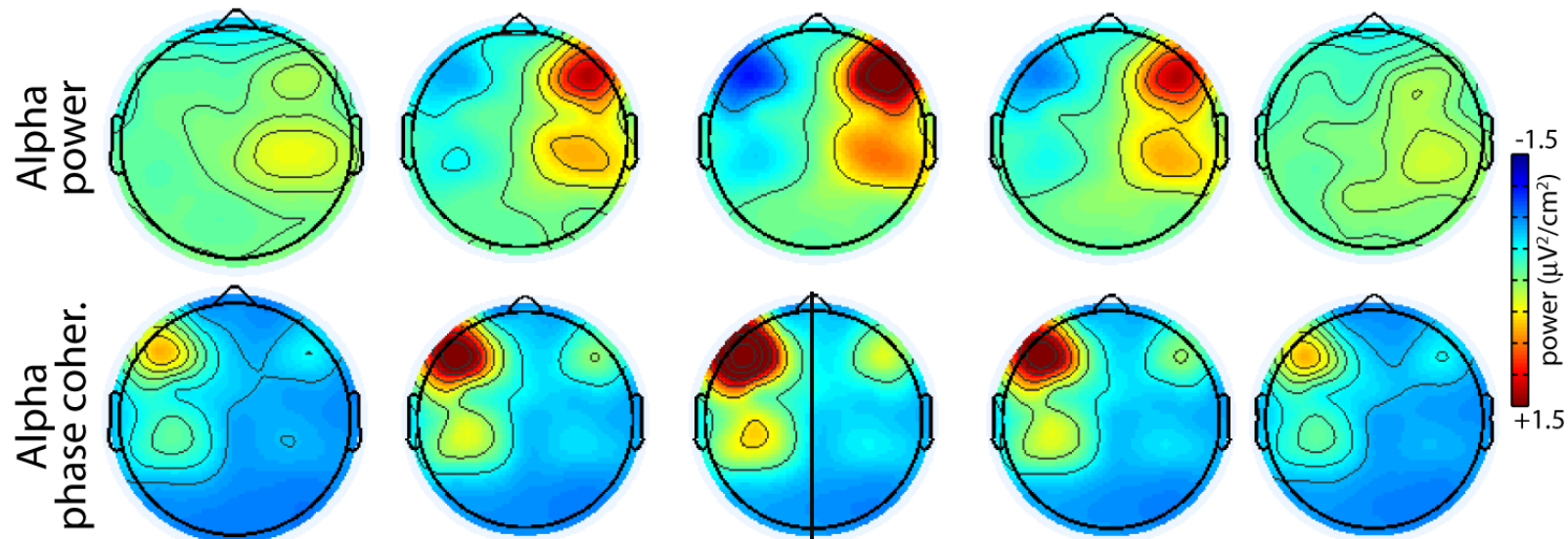

(B) Negative bursts

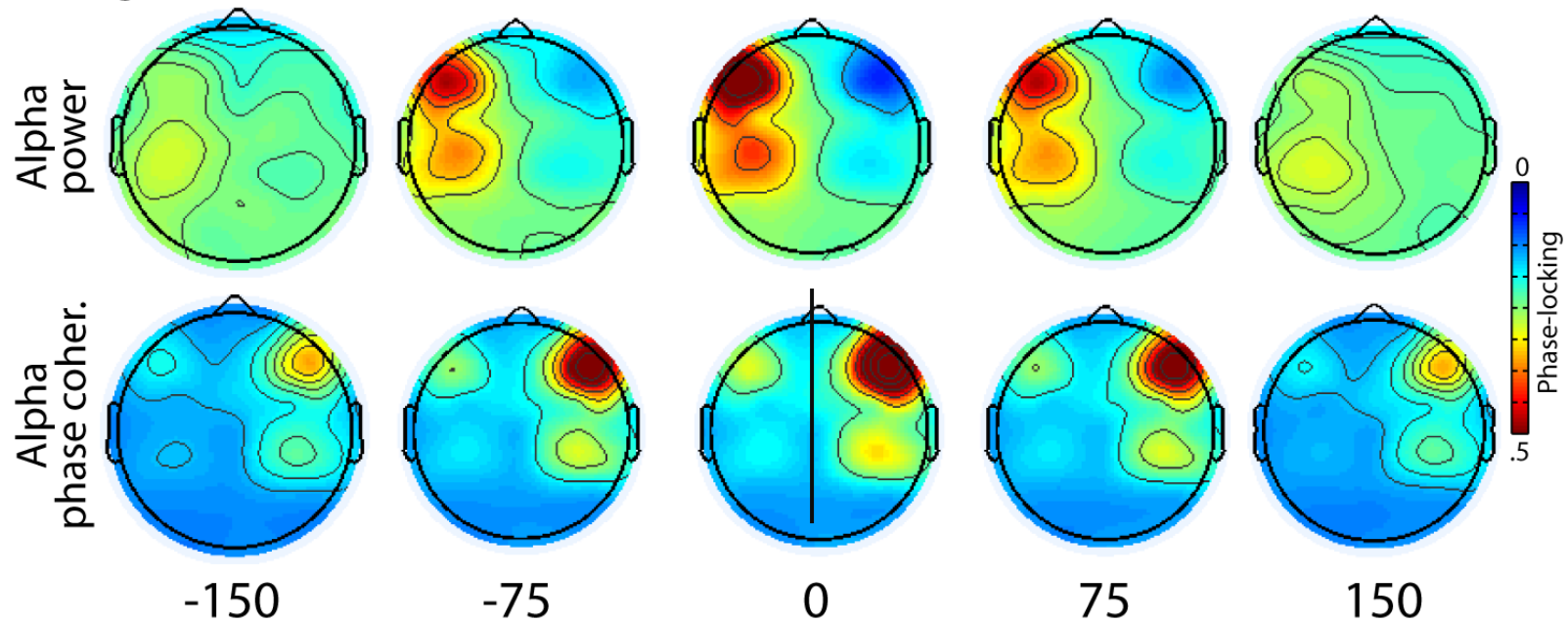

-150

-75

0

75

150

Peri-burst time (ms)

Allen & Cohen, 2010

So?

- ◆ Bursts reflect ...
 - ◆ Transient lateralized alpha suppression that shows a highly consistent phase relationship across bursts
 - ◆ Along with concurrent contralateral transient alpha enhancement that is less tightly phase-locked across bursts

(A) Positive bursts

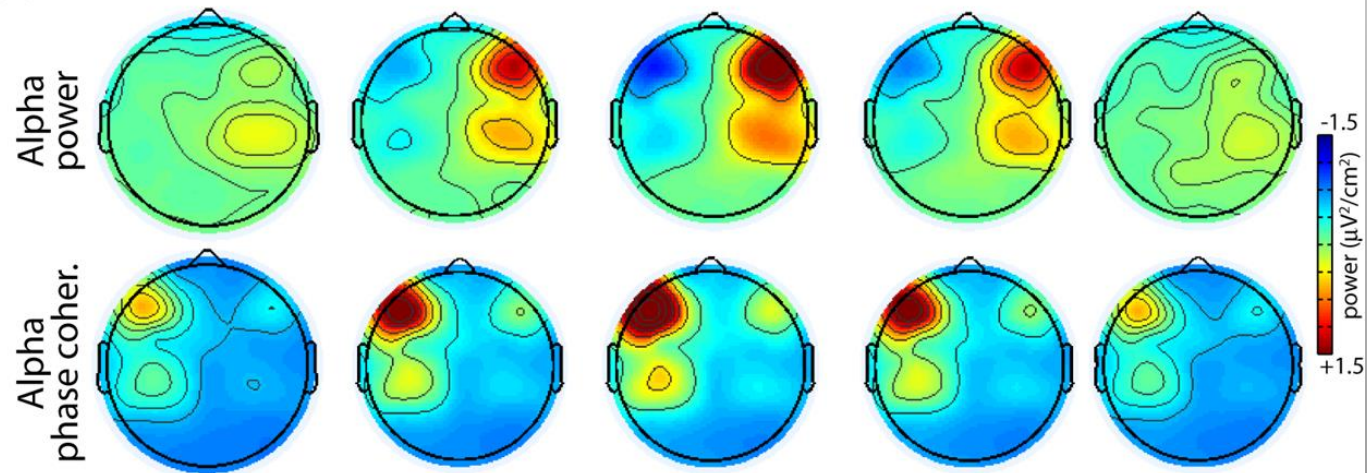

So?

- ◆ The fact that the alpha suppression is particularly tightly phase-locked across bursts raises the possibility that the lateralized alpha suppression may drive or regulate cortical processing
- ◆ Alpha has been shown to regulate gamma power (i.e., cross-frequency coupling, Cohen et al., 2009)

TIME AND SPACE

Multi-modal Imaging

- ◆ Tether EEG asymmetry to other measures neural systems known to be involved in MDD
- ◆ 23 subjects with simultaneous EEG and fMRI during resting state



Multi-modal Imaging

- ◆ Tether EEG asymmetry to other measures neural systems known to be involved in MDD

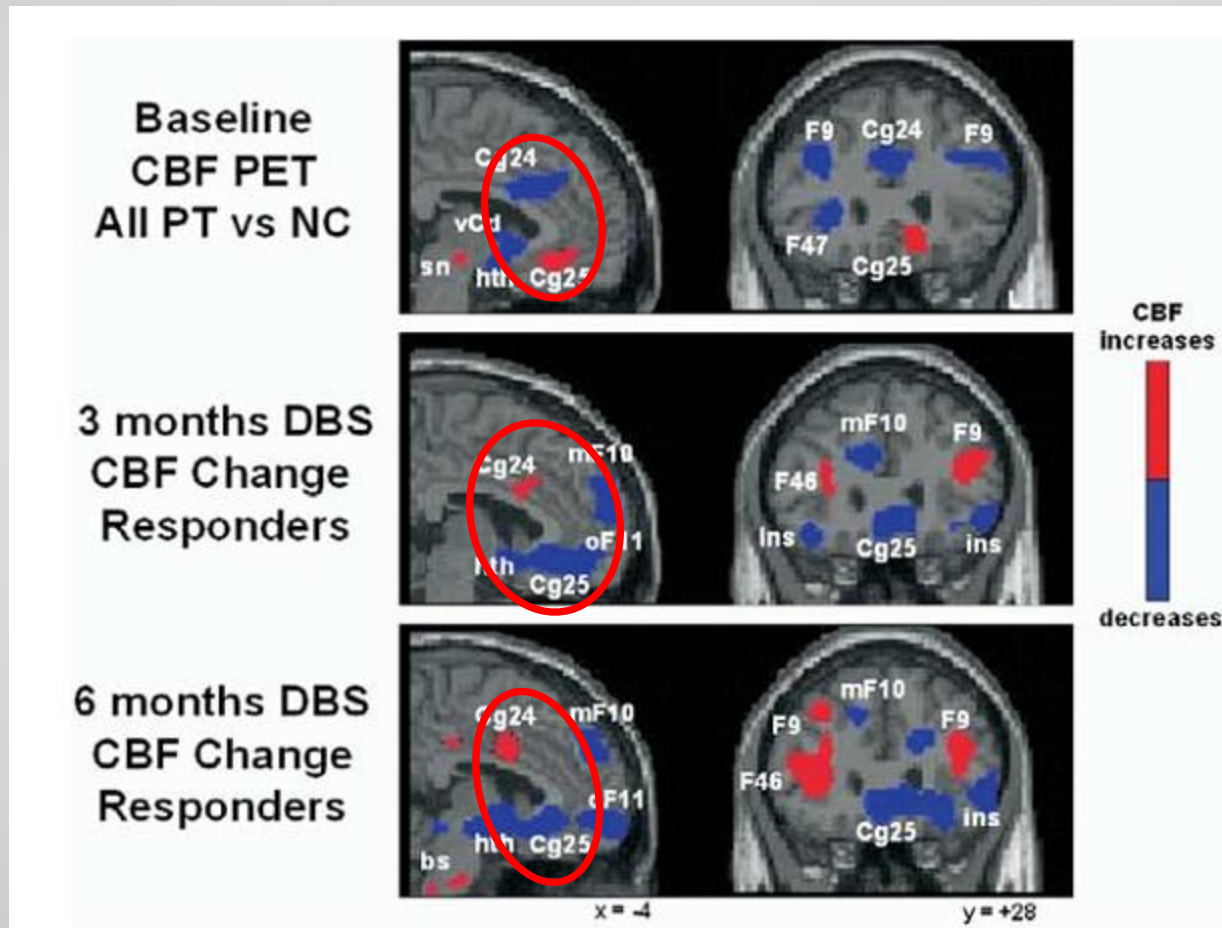

Multi-modal Imaging

- ◆ Create RS-fMRI network with ACC seeds

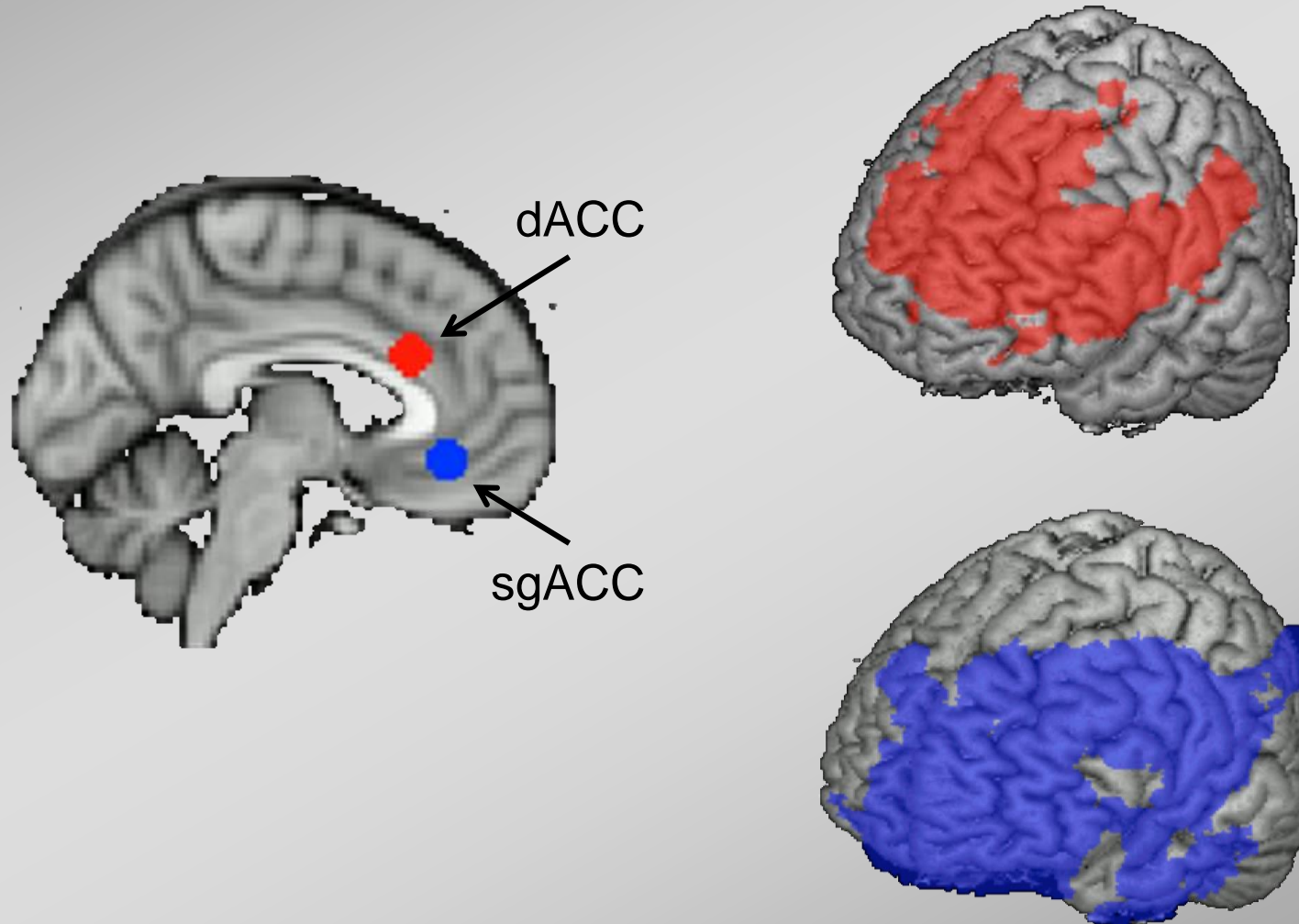

Remove Artifacts from Resting EEG

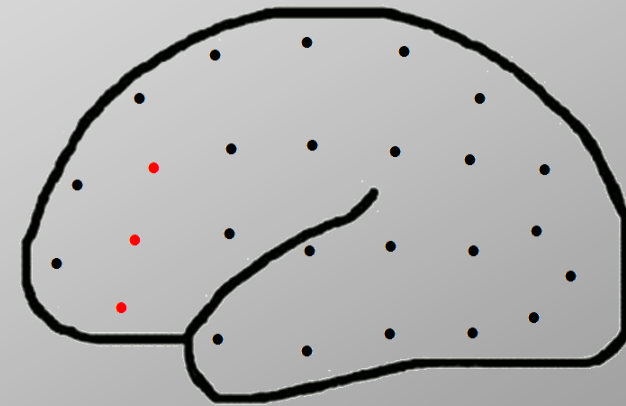
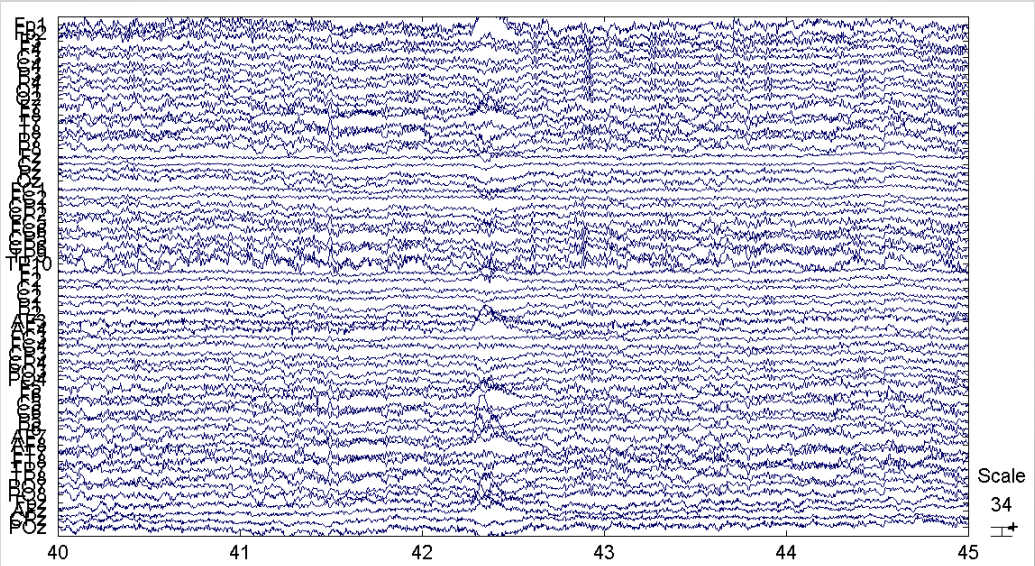
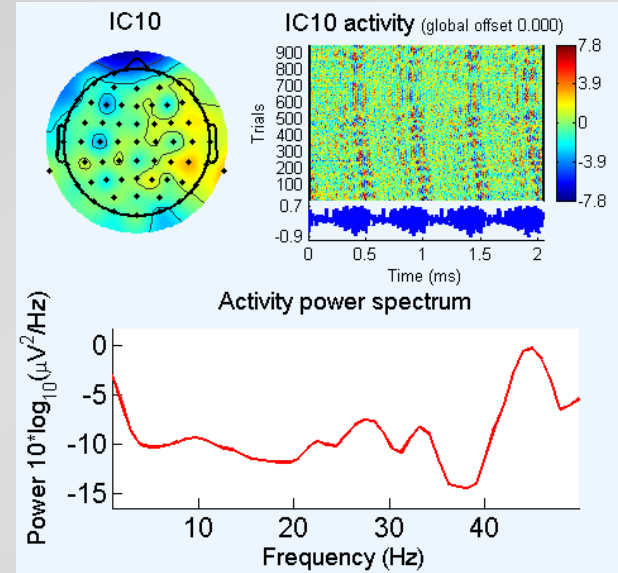
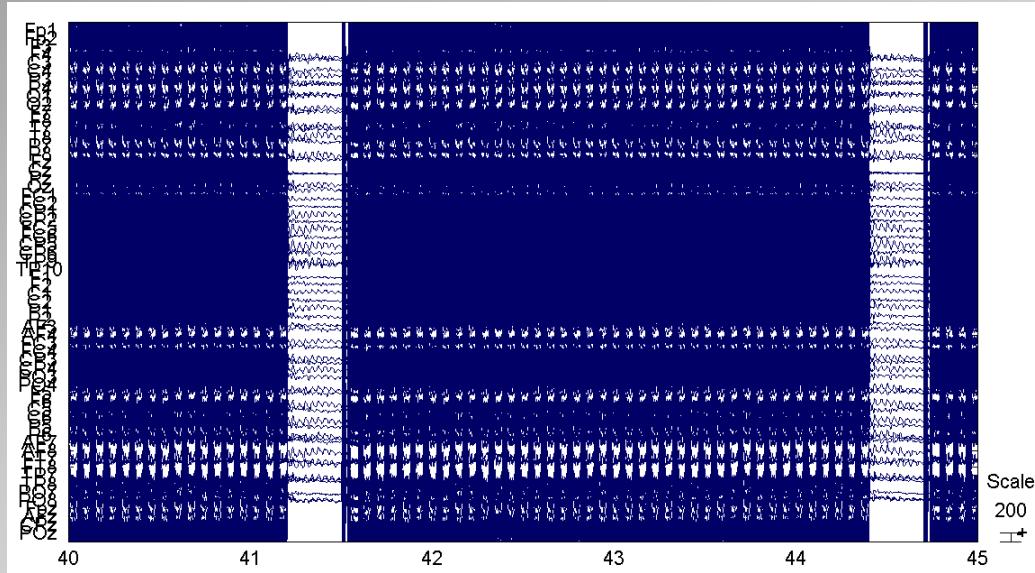

EEG Alpha Asymmetry is Negatively Correlated with IFG Connectivity in Two ACC-seeded Resting State Networks

Spatially-enhanced EEG asymmetry (using CSD transform) at sites F8-F7 is related to resting state connectivity between left inferior frontal gyrus and two ACC-seeded networks.

Dorsal ACC-seeded Network

Center of the depicted cluster is (x,y,z) -46, 28, -4 MNI coordinates.

Largest correlation: $r = -0.69$

Subgenual ACC-seeded Network

Center of the depicted cluster is (x,y,z) -54, 28, -4 MNI coordinates.

Largest correlation: $r = -0.71$

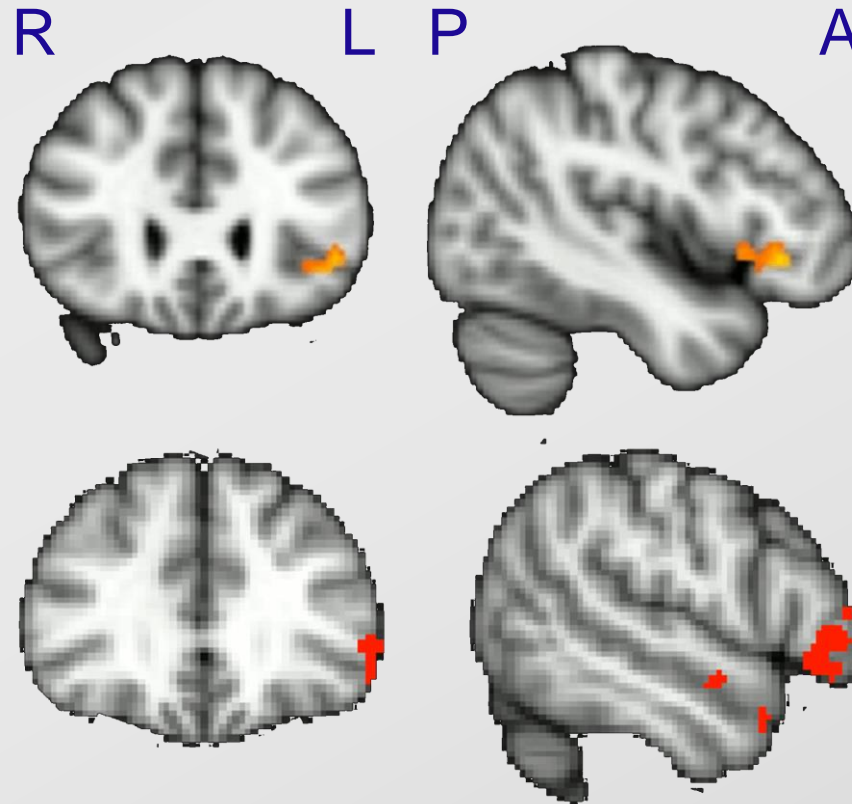

EEG-fMRI Synopsis

- ◆ Less relative left frontal activity (indexed by EEG) is related to increased connectivity of left IFG to two ACC-seeded RS networks
- ◆ Consistent with:
 - ◆ Hyper-connectivity in RSfMRI emotion networks in MDD (e.g., Greicius et al., 2007; Sheline et al., 2010; Kaiser et al., 2015)
 - ◆ Frontal EEG asymmetry findings of less relative left frontal activity in risk for MDD.
- ◆ Alpha power may regulate network connectivity
 - ◆ Note: Between vs Within Subjects



BETWEEN-SUBJECTS' DATA DOES NOT NECESSARILY SUPPORT A WITHIN-SUBJECTS' INTERPRETATION

Within Subjects' Moderation of RSfMRI Connectivity

- ◆ Calculate F8-F7 alpha asymmetry for each TR
 - ◆ EEG leads TR by 4.096 seconds
- ◆ Median split into high (left) and low (right)
- ◆ Entered as moderator in PPI approach (cf. Friston et al., 1997)
 - ◆ Tests whether strength of connectivity to seed region varies as a function of the moderator

Within Subjects' Moderation of RSfMRI Connectivity

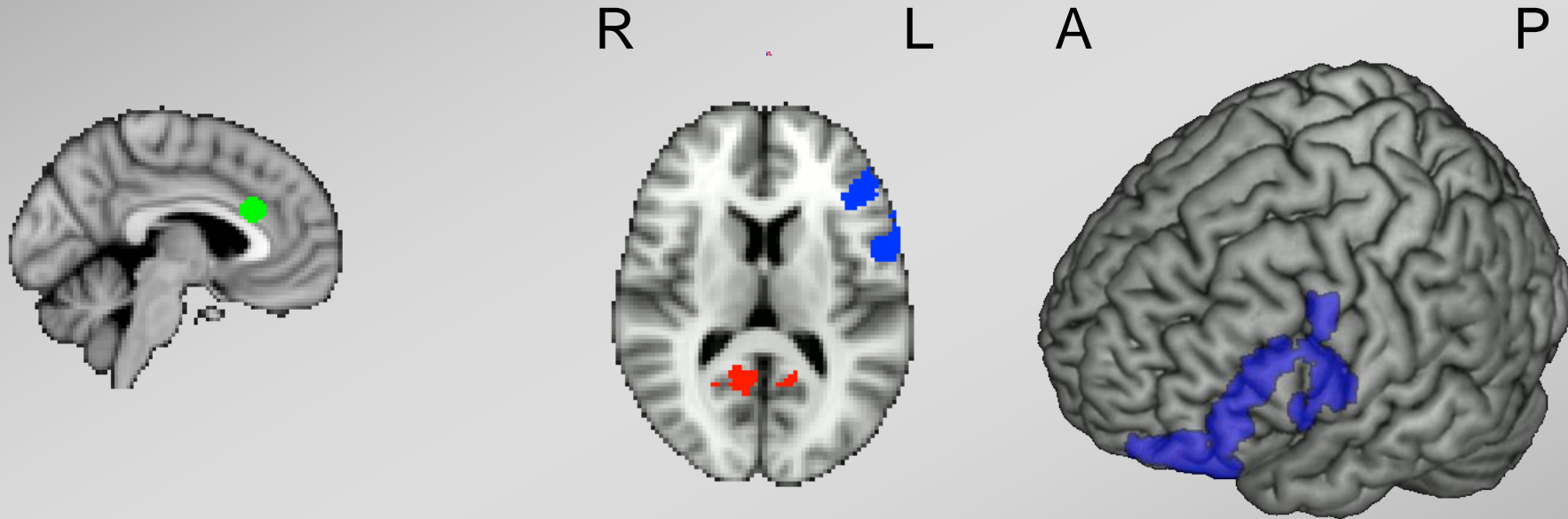

Dorsal ACC Seed

Greater Connectivity with
Less Left Frontal Alpha or
Greater Left Frontal Alpha

Within (red) and Between (blue)
Within-subject effects more extensive

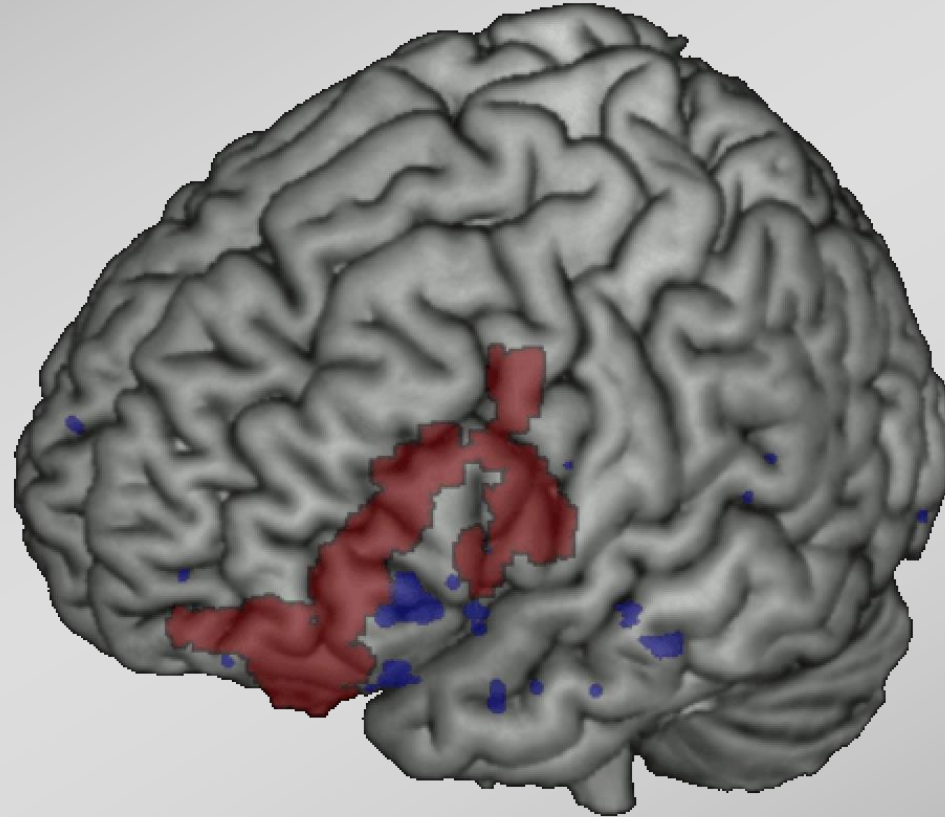

Cognitive Control over Emotion

- ◆ IFG has a key role in mediating the success of cognitive control over emotional stimuli

Cognitive Control over Emotion

◀ Left IFG:
Language and
self-referential
processing

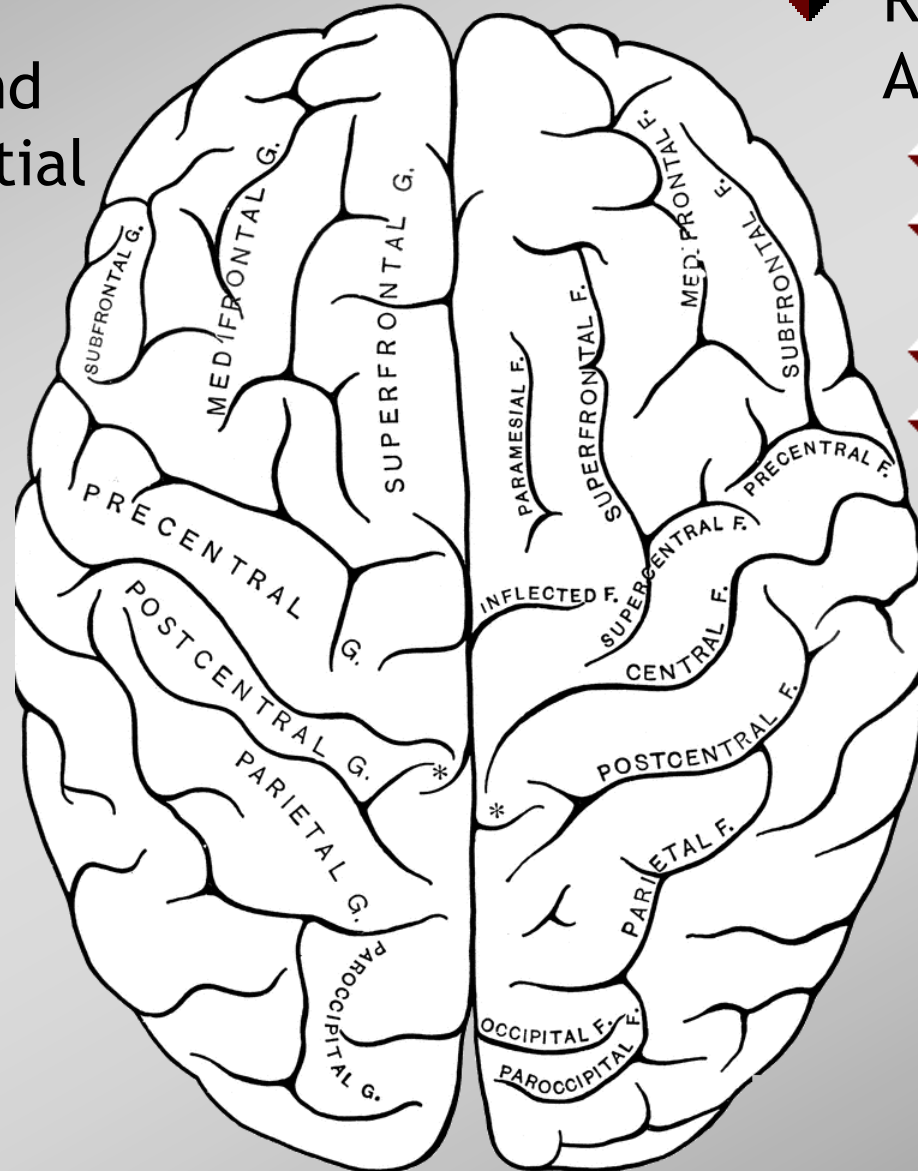

◀ Right IFG:
Attentional control

- ▶ behavioral inhibition
- ▶ suppression of unwanted thoughts
- ▶ attention shifting
- ▶ efforts to reappraise emotional stimuli

Cognitive Control over Emotion

◆ Left IFG:
Language and
self-referential
processing

◆ Right IFG:
Attentional control

- ◆ behavioral inhibition
- ◆ suppression of unwanted thoughts
- ◆ attention shifting
- ◆ efforts to reappraise emotional stimuli

◆ Working Hypothesis:

- ◆ Hyperconnected left IFG* and emotion networks:
rumination
- ◆ Hypoconnected right IFG: difficulty disengaging from emotion

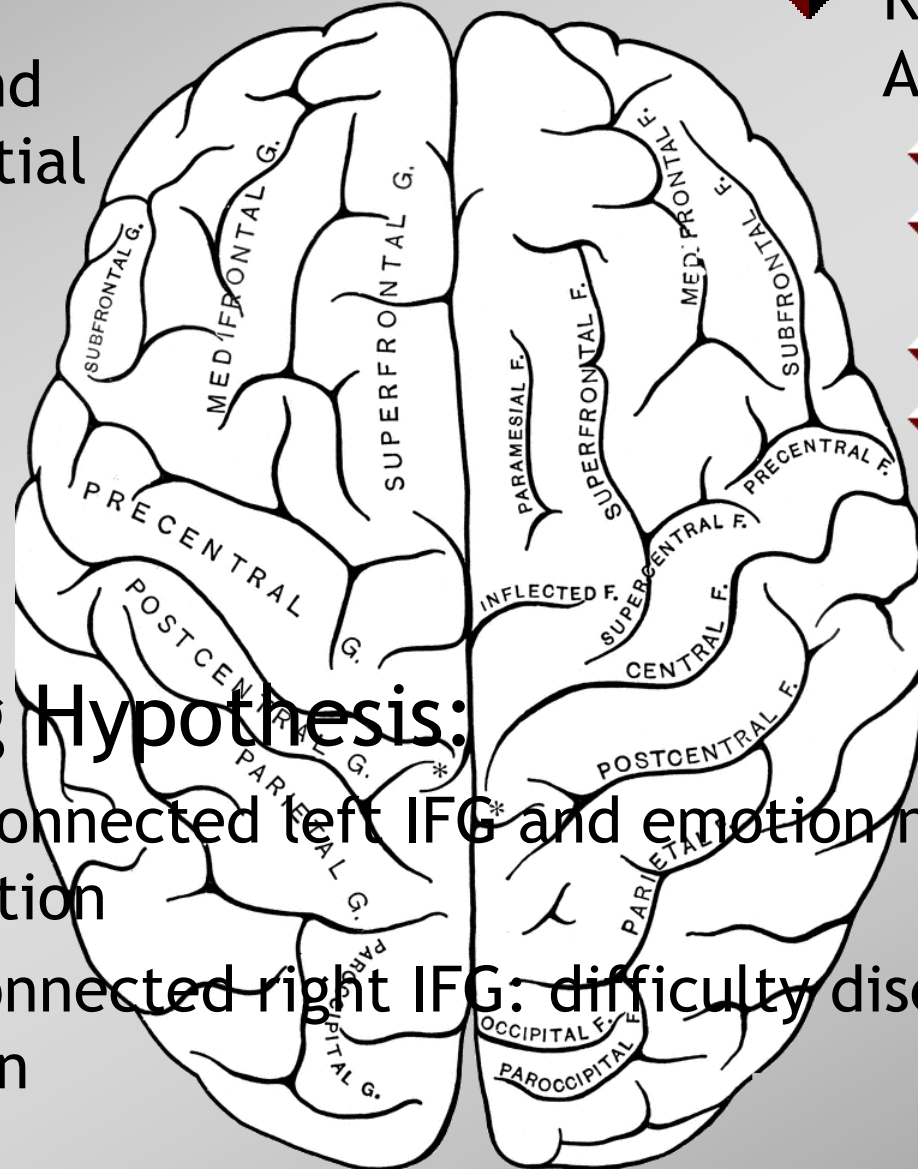

Synchronization and Desynchronization

- Supposition that alpha blocking meant that the EEG had become desynchronized
 - Yet the activity is still highly synchronized -- not at 8-13 Hz
 - May involve fewer neuronal ensembles in synchrony

If Alpha Desynchs, what Synchs?

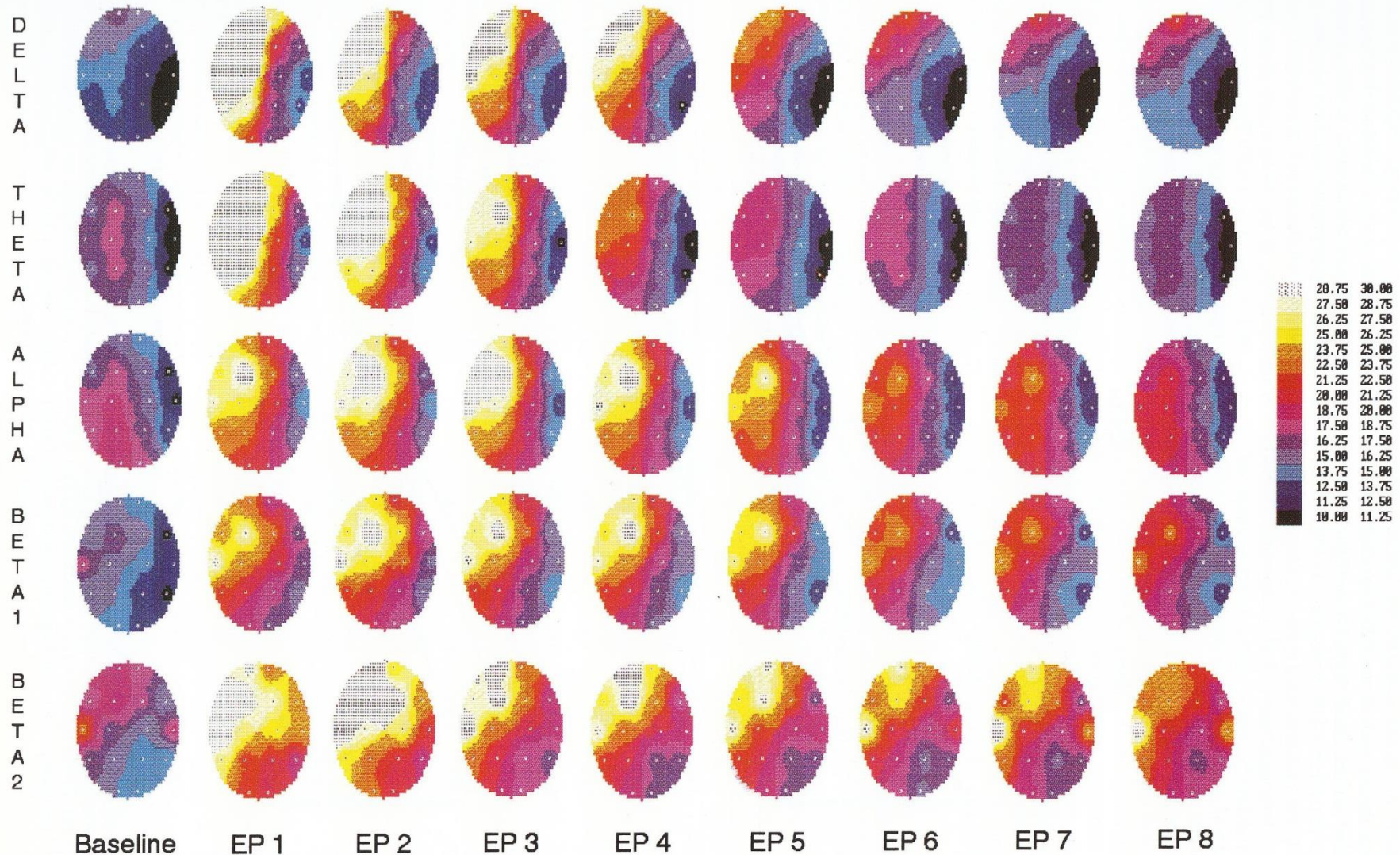

Event-related Synchronization and Desynchronization

- Pfurtscheller (1992) -- Two types of ERS
 - Secondary (follows ERD)

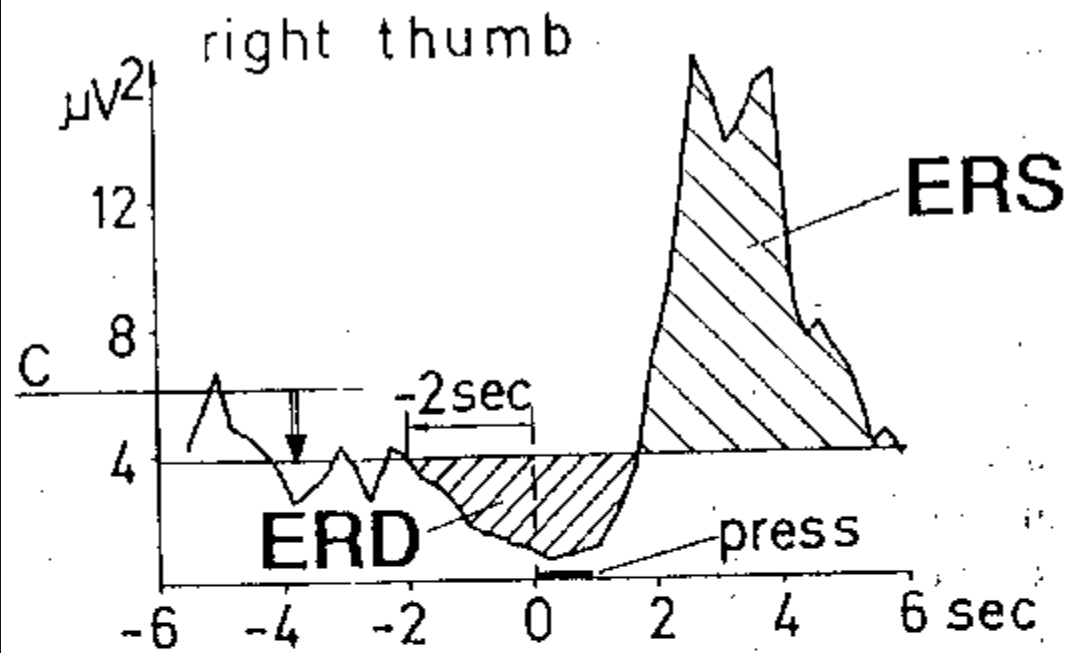

Alpha Power time course over left central region during voluntary movements with right and left thumb

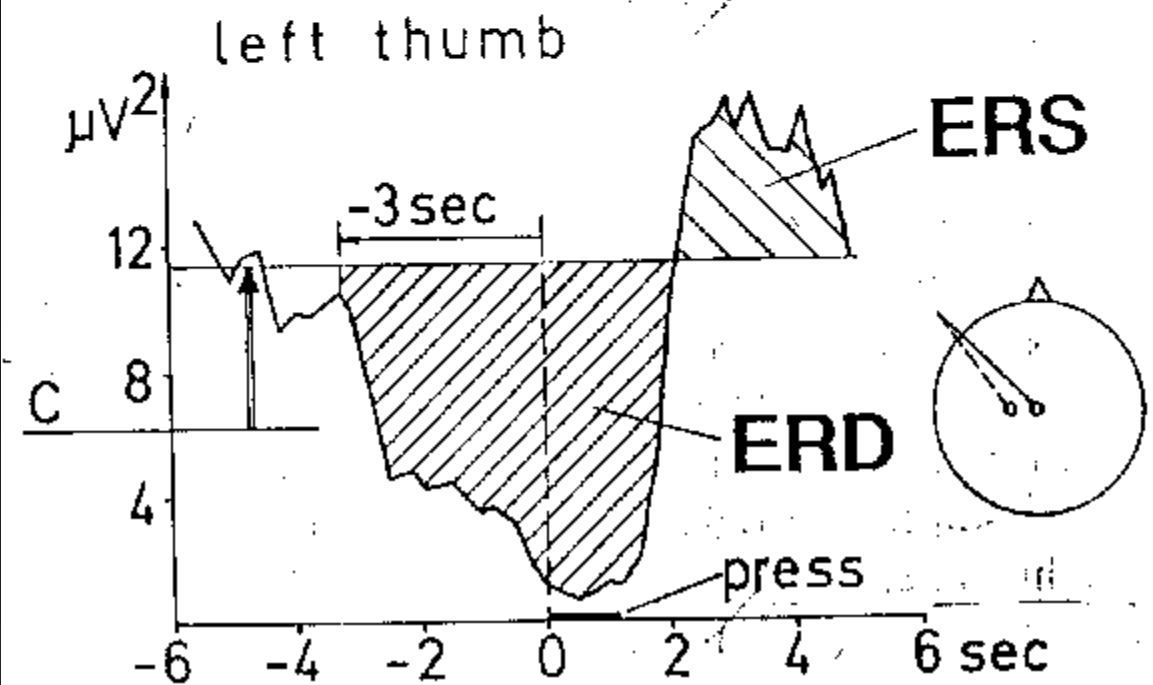

Event-related Synchronization and Desynchronization

- Pfurtscheller (1992) -- Two types of ERS
 - Secondary (follows ERD)
 - Primary (**Figure 3 & Figure 4**)

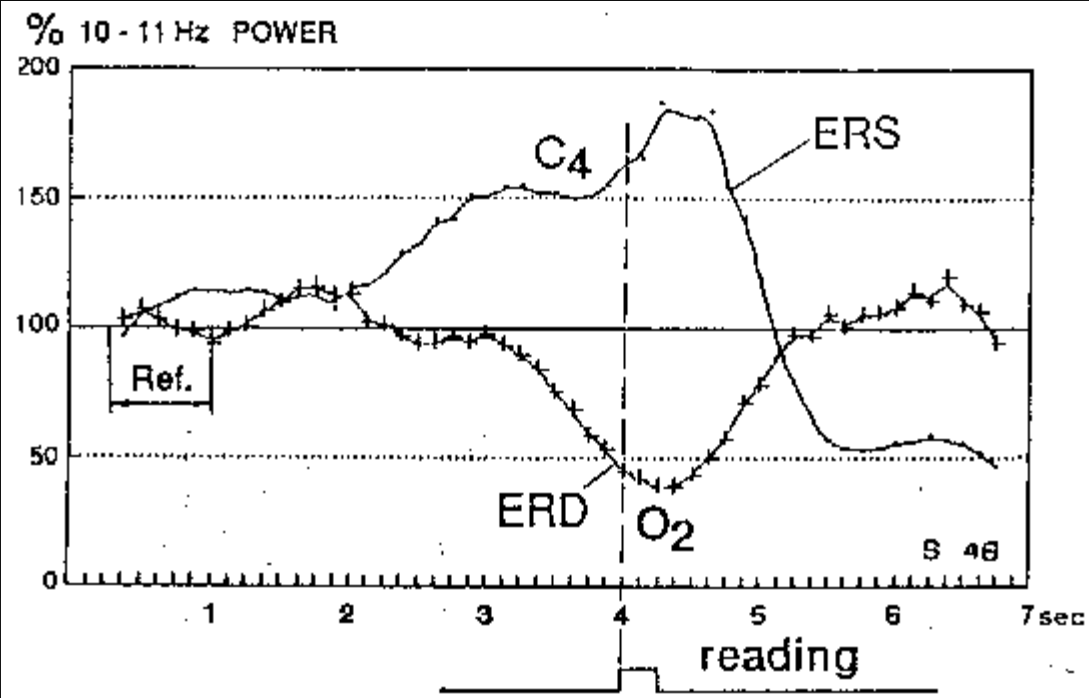

Alpha power time course during reading (upper) and voluntary finger movements (lower). Primary ERS is seen over electrodes overlying cortical areas not involved in the task.

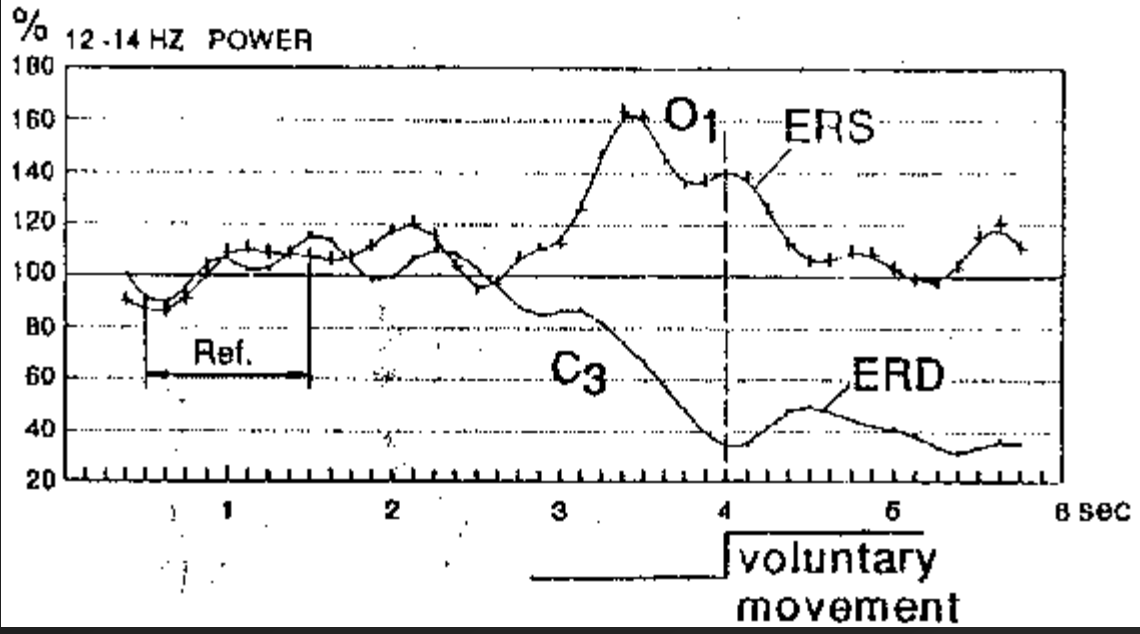

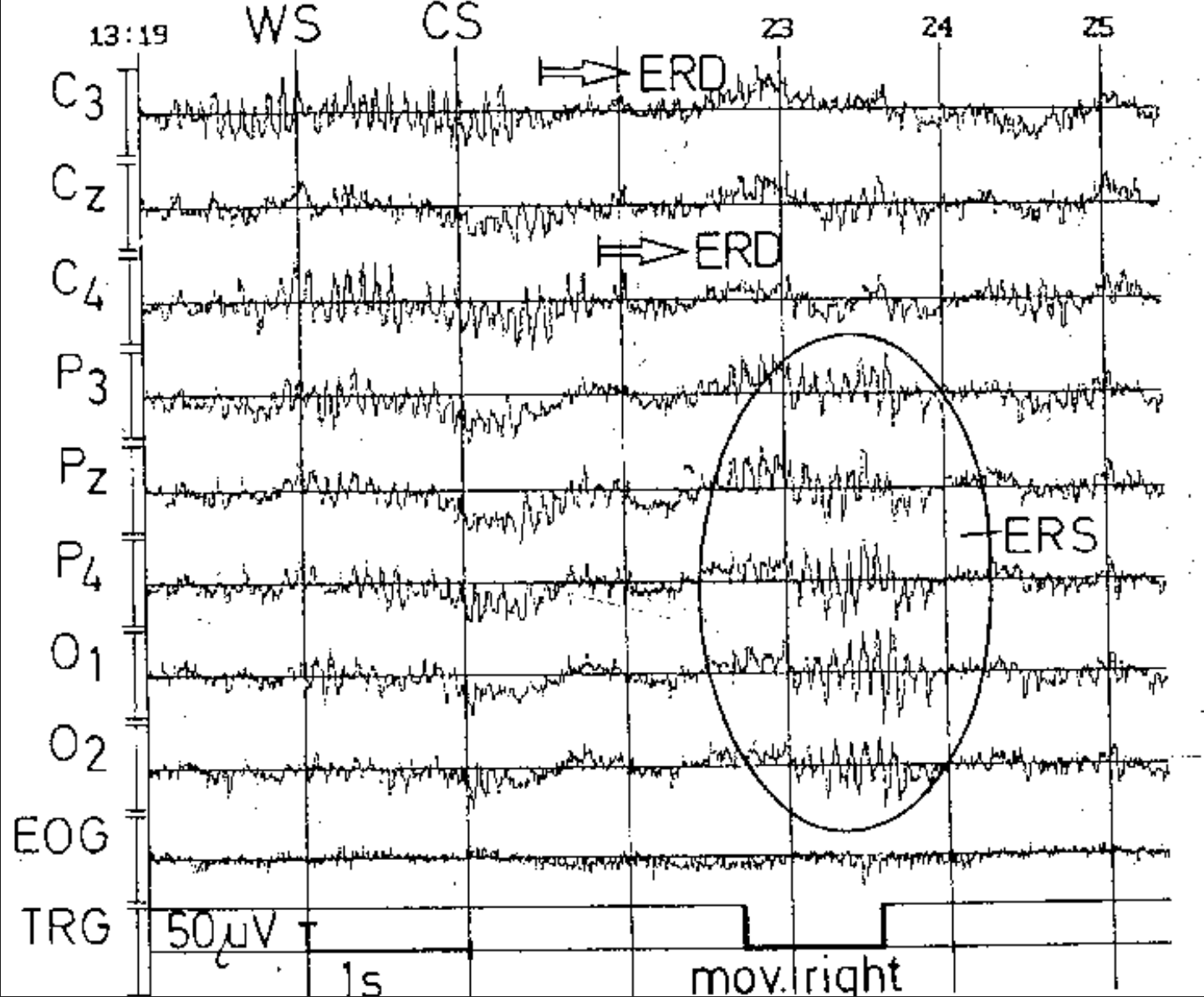

Primary ERS seen over parietal and occipital leads during right finger movement. ERD is seen over central electrodes, with earlier onset over hemisphere contralateral to movement.

40 Hz Activity

- First reports of important 40 Hz activity
- Sheer & Grandstaff (1969) review
 - pronounced rhythmic electrical bursting
- Daniel Sheer's subsequent work until his death renewed interest in "40 Hz" phenomena

Sheer work with Cats

- Learning paradigm
- Cat must learn
 - press to S_D (7cps light flicker)
 - not S_- (3 cps light flicker)
 - the hypothesis is that the synchronized 40 Hz activity represents the focused activation of specific cortical areas necessary for performance of a task

STIMULUS PERIOD 7/SEC FLICKER WITH RESPONSE

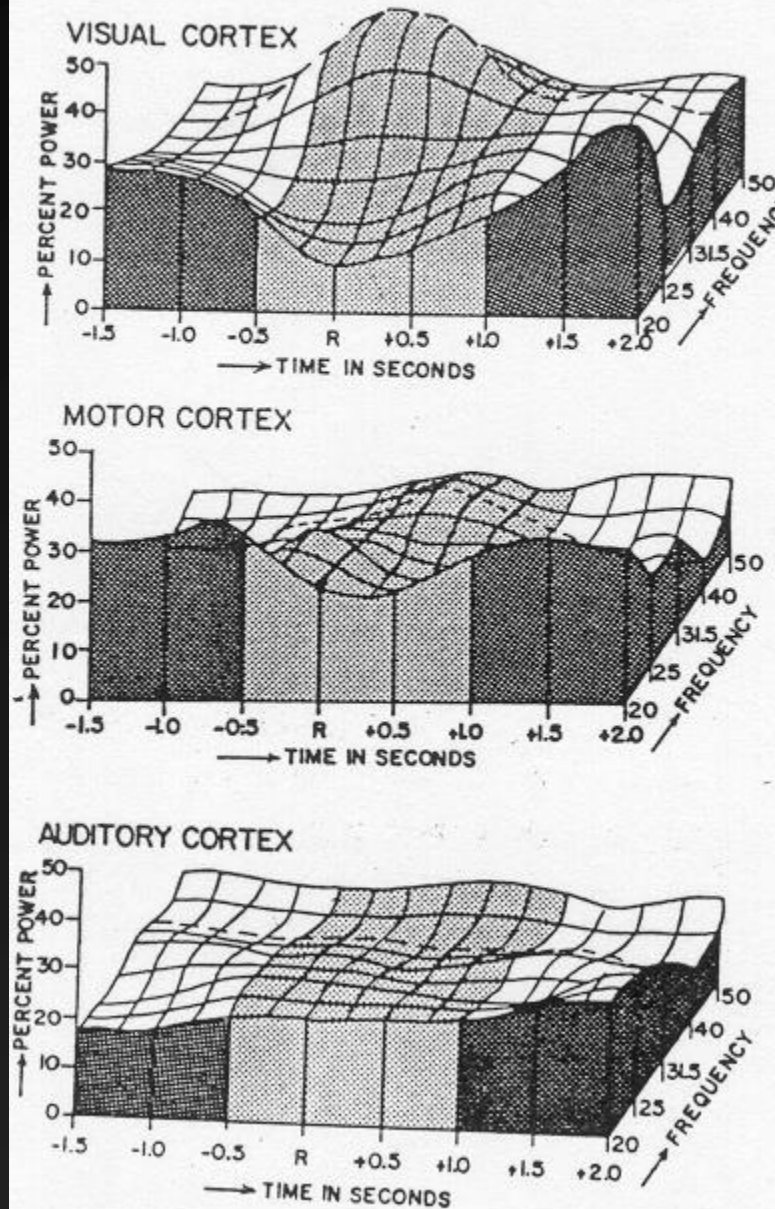

Note specificity of response to S_D , over visual cortex to discriminative stimulus, in 40-Hz range; Some hint of it later in the motor cortex. Note also decreased activity in slower bands during the same time periods.

VISUAL CORTEX

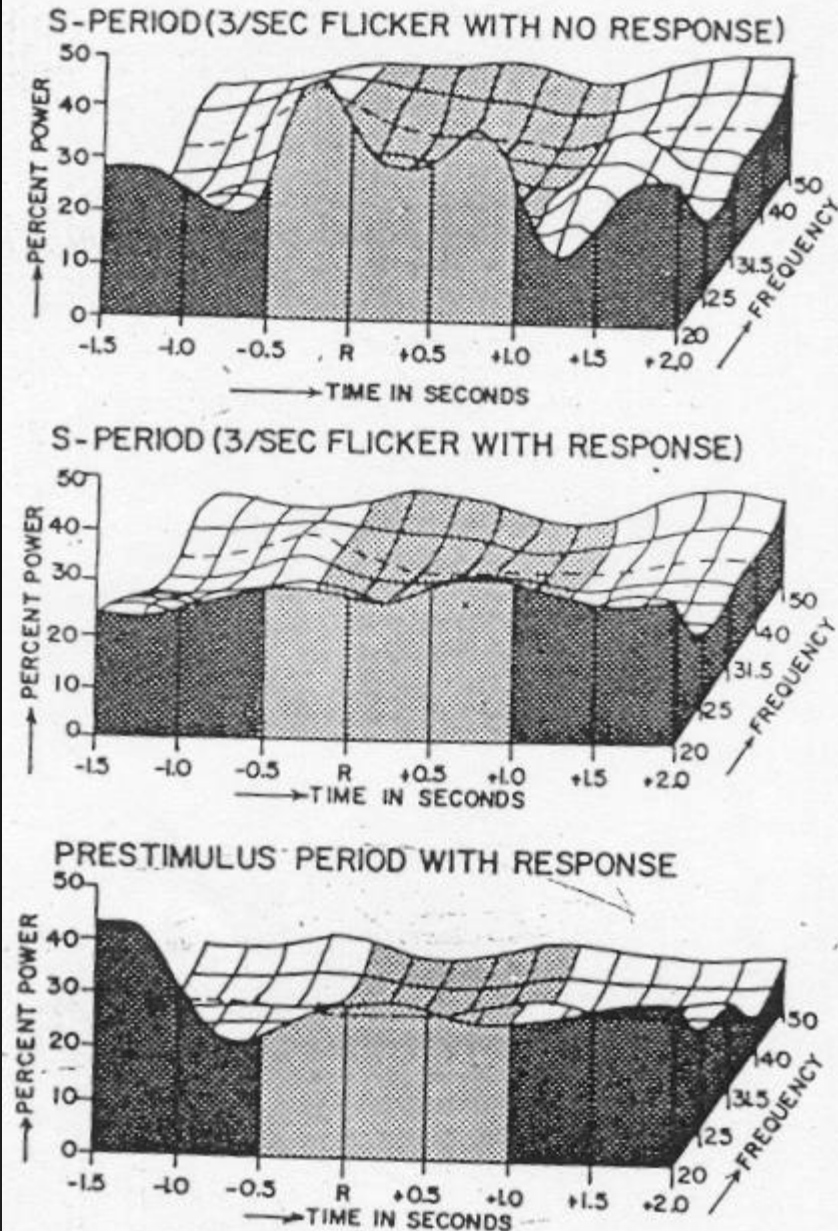

Note very different pattern to S-. No 40-Hz change in visual cortex, and marked increase in lower frequencies at same time period.

Human Studies

- Hypothesis is that 40 Hz activity correlates with the behavioral state of focused arousal (Sheer, 1976) or cortical activation
 - a "circumscribed state of cortical excitability" (Sheer, 1975)
 - Bird et al (1978)
 - biofeedback paradigm
 - increased 40 Hz activity is associated with high arousal and mental concentration
 - Ford et al., (1980)
 - subjects once trained to voluntarily suppress 40 Hz EEG are unable to maintain that suppression while simultaneously solving problems
 - concluded that problem solving and absence of 40 Hz are incompatible

Lateralized Task Effects

- Loring & Sheer (1984)
 - right-handed students
 - analogies task
 - spatial Task
- Results transformed into laterality ratios:
 - $(L-R)/(L+R)$ 40 Hz
 - higher # => greater LH activity (P3-O1-T5 triangle vs P4-O2-T6 triangle);
- Results
 - greatest variability during baseline
 - smallest variability and greatest LH activation during verbal
 - no laterality effects in the 40Hz EMG bands

Laterality of 40 Hz

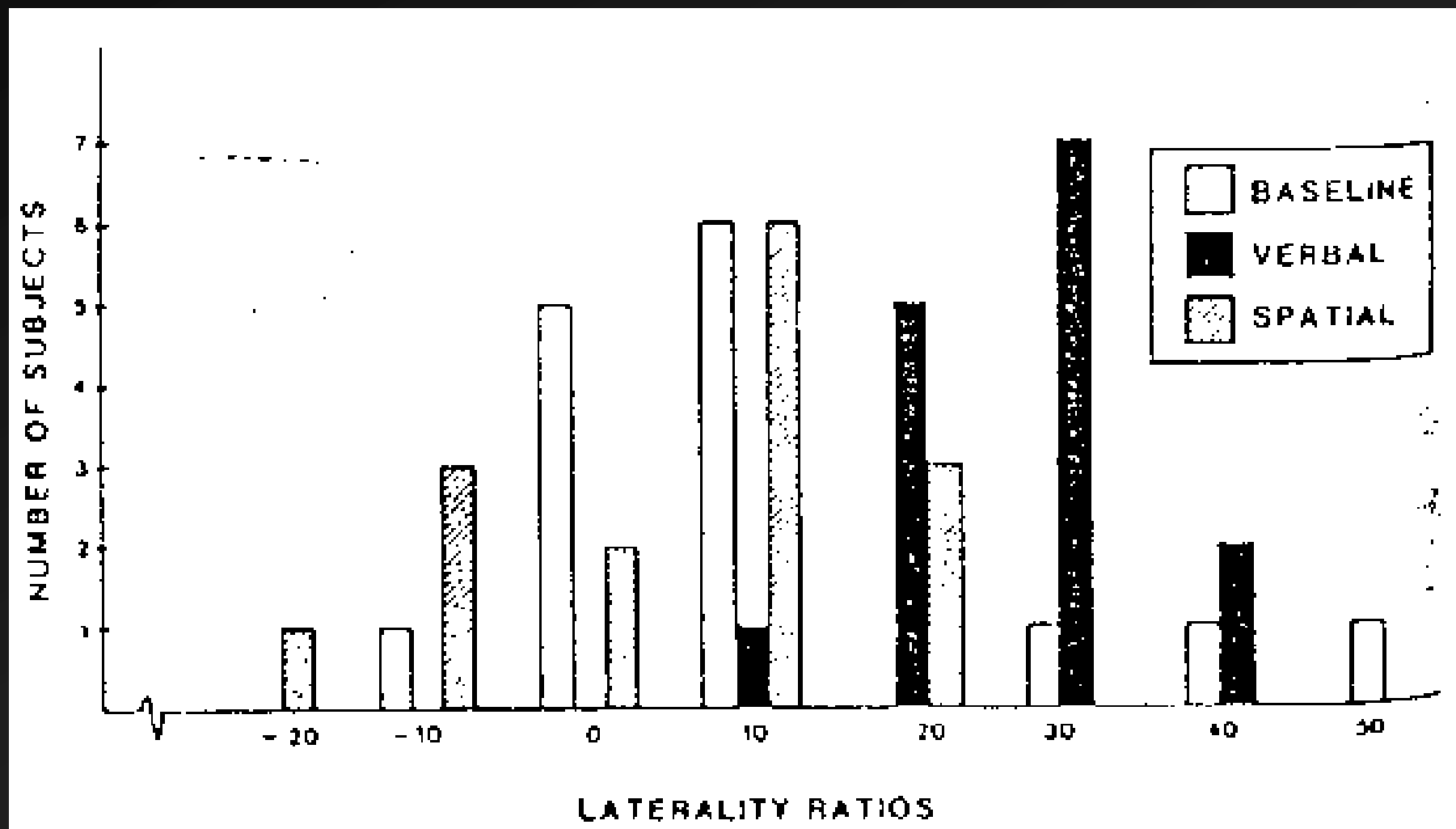

Controlling for EMG contributions

- Spydell & Sheer (1982)
 - used similar tasks and found similar results
 - using conservative controls for muscle artifact

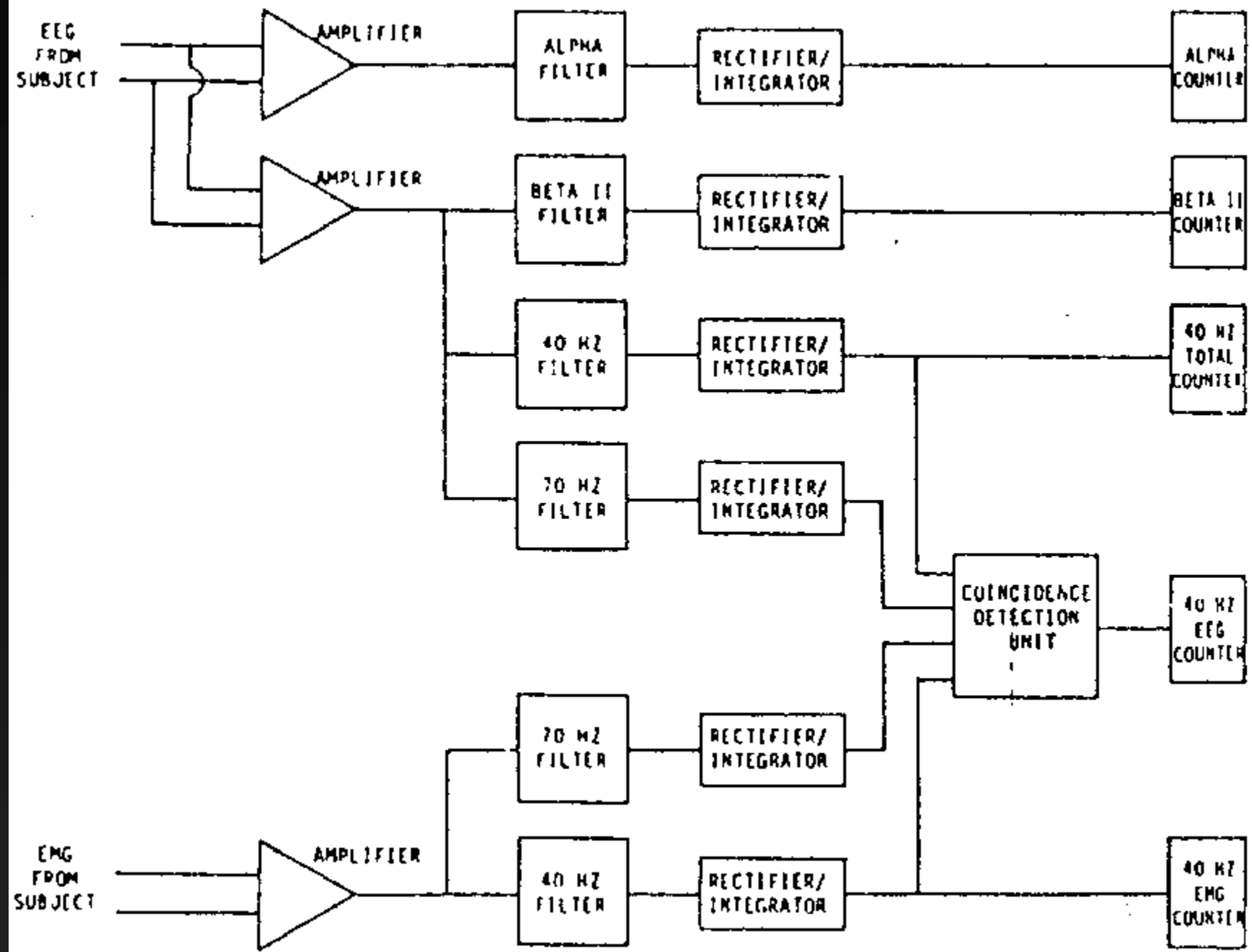

TABLE 1
Median changes in rate scores

Problems	Median Rate Score Changes									
	Alpha		Beta II		40 Hz Total		40 Hz EEG		40 Hz EMG	
	Left	Right	Left	Right	Left	Right	Left	Right	Left	Right
Verbal	-36.7*	-52.4*	-20.1*	-20.2*	1.0*	0.1	1.2*	0.1	8.4*	10.6*
Rotation	-36.7*	-37.6*	-15.3*	-15.3*	0.7	1.0*	0.4	0.9*	13.9*	8.9*

* $p < .05$.

Spydell and Sheer

Vol.

TABLE 3
Spearman rank-order correlations between various 40 Hz activity measures

40 Hz Measures	Correlations							
	Verbal Left		Verbal Right		Rotations Left		Rotations Right	
	40 Total	40 EEG	40 Total	40 EEG	40 Total	40 EEG	40 Total	40 EEG
40 Hz EEG	.74*		.68*		.94*		.78*	
40 Hz EMG	.27	.28	.39	.05	.27	.35	.16	.25

* $p < .05$.

Individual Differences

- Spydell & Sheer (1983), Alzheimer's
 - controls showed task related changes in EEG with appropriate lateralization
 - Alzheimer's did not
- Schnyer & Allen (1995)
 - Most highly hypnotizable subjects showed enhanced 40 hz activity

So this is exciting, why didn't this work take off immediately?

- The EMG concern
 - The concern is likely over-rated (recall **Table 3**)
- Sheer died
- But not all is lost, as there is renewed interest...

Patient #1

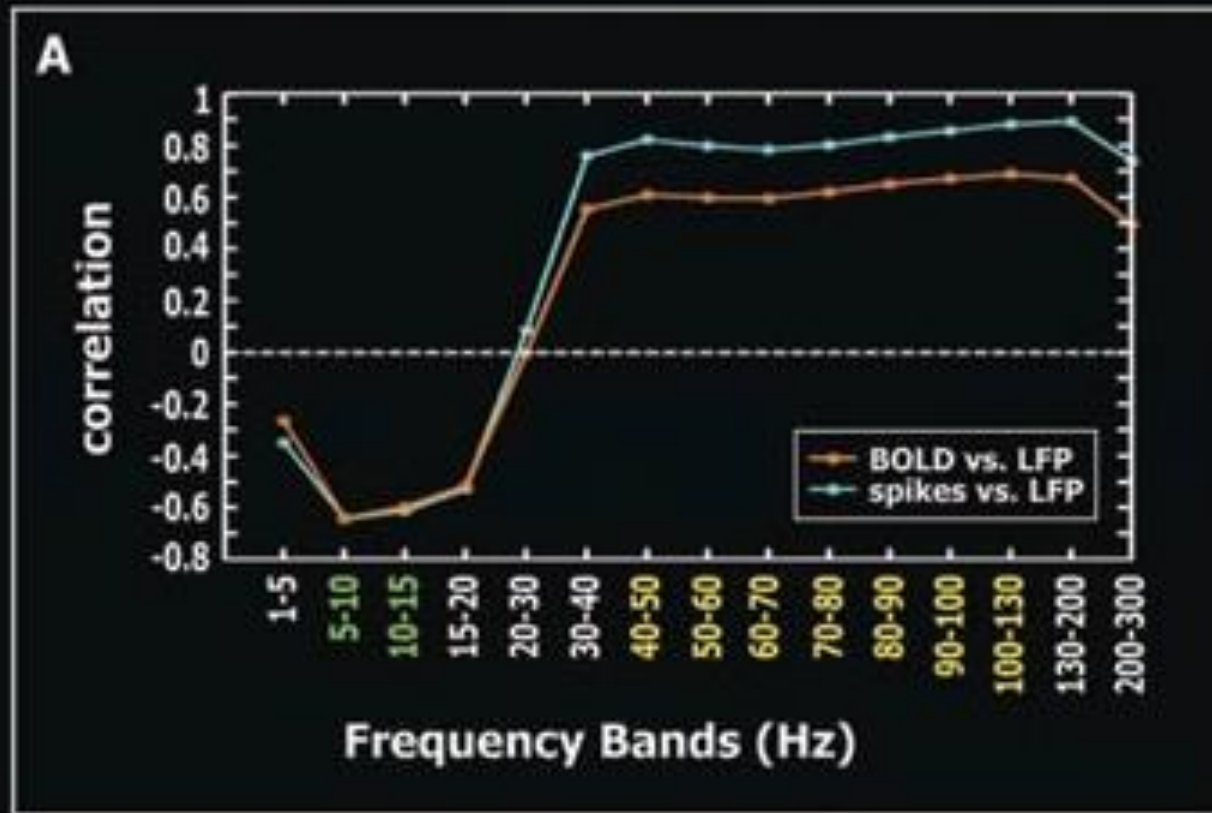

Mukamel et al *Science* 2005

recorded single unit activity and local field potentials in auditory cortex of two neurosurgical patients and compared them with the fMRI signals of 11 healthy subjects during presentation of an identical movie segment. The predicted fMRI signals derived from single units and the measured fMRI signals from auditory cortex showed a highly significant correlation.

Singer (1993)

- Revitalized interest in the field

The Binding Problem

- Potentially infinite number of things and ideas that we may attempt to represent within the CNS
 - Cells code for limited sets of features,
 - These must somehow be integrated
 - -- the so-called binding problem
- If there exists a cell for a unique contribution of attributes, then convergent information from many cells could converge on such a cell
 - But there are a finite # of cells and interconnections
- And even the billions and billions of cells we have cannot conceivably handle the diversity of representations

The Functional Perspective

-- as yet merely a theory

- There is no site of integration
 - Integration is achieved through simultaneous activation of an assembly of neurons distributed across a wide variety of cortical areas
 - Neurons in such assemblies must identify with other neurons within the assembly while remaining distinct from other neurons
 - This association with other neurons is achieved through a specific code of firing (Synchronicity)
 - This even allows for the possibility of interaction between two parts of two active assemblies (via

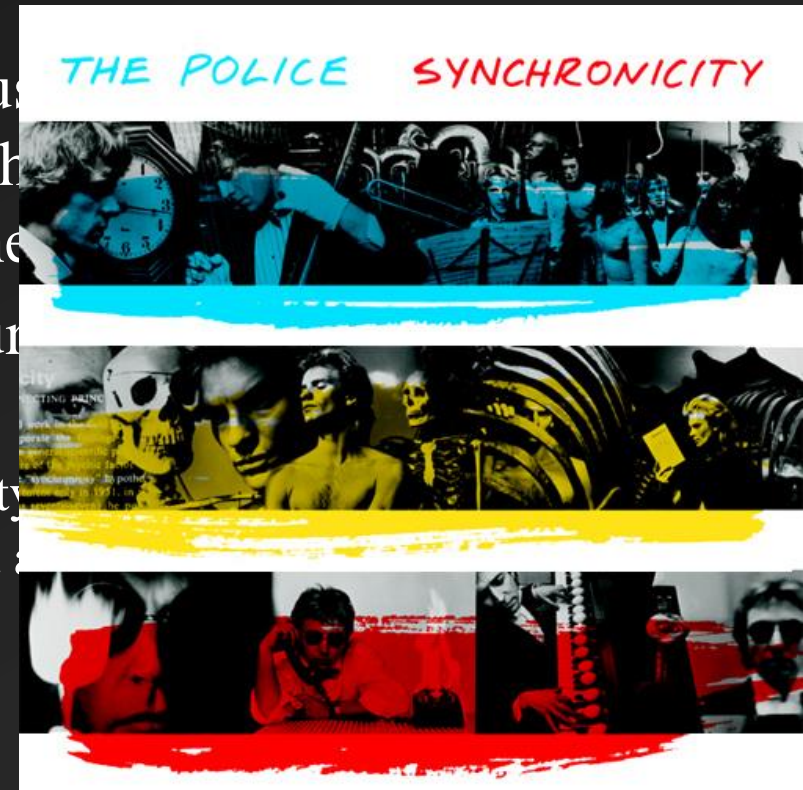

Implications

- Also allows for the possibility that there exists no direct neuronal connection between neurons within an assembly
 - merely the fact that they are simultaneously activated that makes the unified experience of the object possible
- Yet what can synchronize these oscillations?

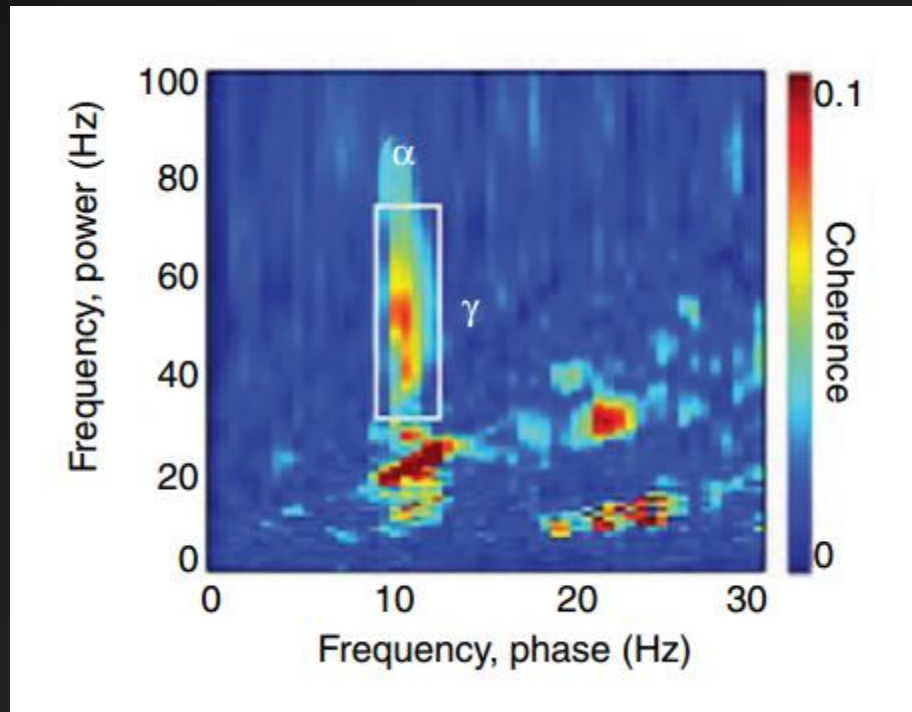

Implications – Alpha as a synchronization mechanism

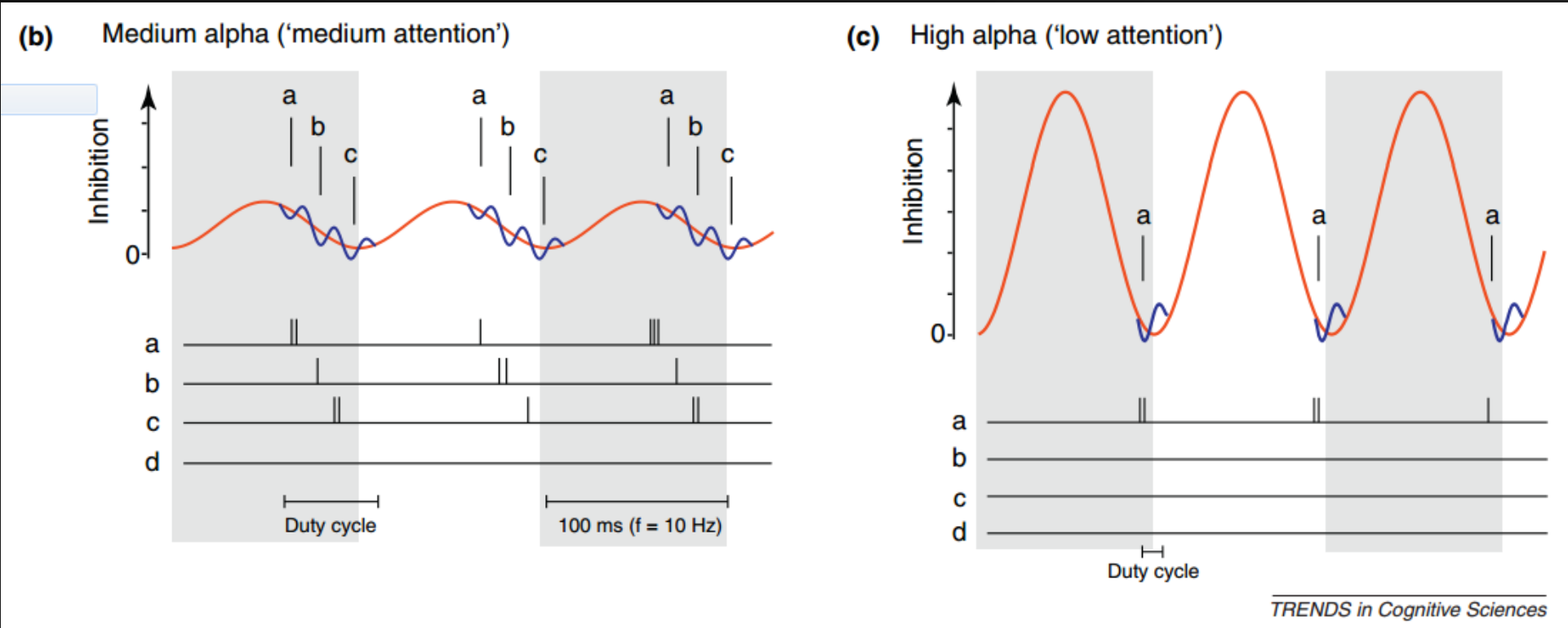

Functional Role of Gamma Synchronization

➤ Feedforward coincidence detection

- To summate effectively, signals must arrive at post-synaptic neuron from multiple sources within msec of each other (else decay)
- Gamma-band synchronization can lead to temporal focusing of inputs from multiple and distributed pre-synaptic neurons

➤ Rhythmic Input Gain Modulation

- Excitatory input is most effective when it arrives out of phase with inhibitory input and vice versa
- Allows for precision and efficiency of signal transmission (or inhibition)

Implications

- This view is a dynamic view
 - depends on experience
 - can change with experience
- Synchronously activated units more likely to become enhanced and part of an assembly that will subsequently become synchronously activated
- Singer concludes:
 - Points out the problem of looking for synchronous activation on the micro level, suggesting that a return to the EEG literature looking for task-dependent synchronization in the gamma (aka 40 Hz) band!
- “Forty-Hz” activity is alive and well
 - “Forty” = $40 \pm$ some range
 - Gamma! (Stay tuned during advanced topics)

The Event-Related Potential (*aka* the ERP)

Overview

Event-related potentials are patterned voltage changes embedded in the ongoing EEG that reflect a process in response to a particular event: e.g., a visual or auditory stimulus, a response, an internal event



Ongoing EEG

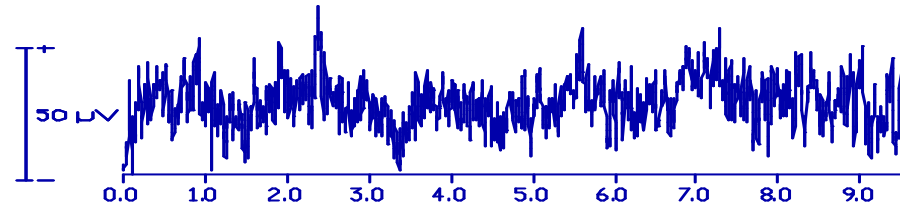

Stimuli



Visual Event-related Potential (ERP)

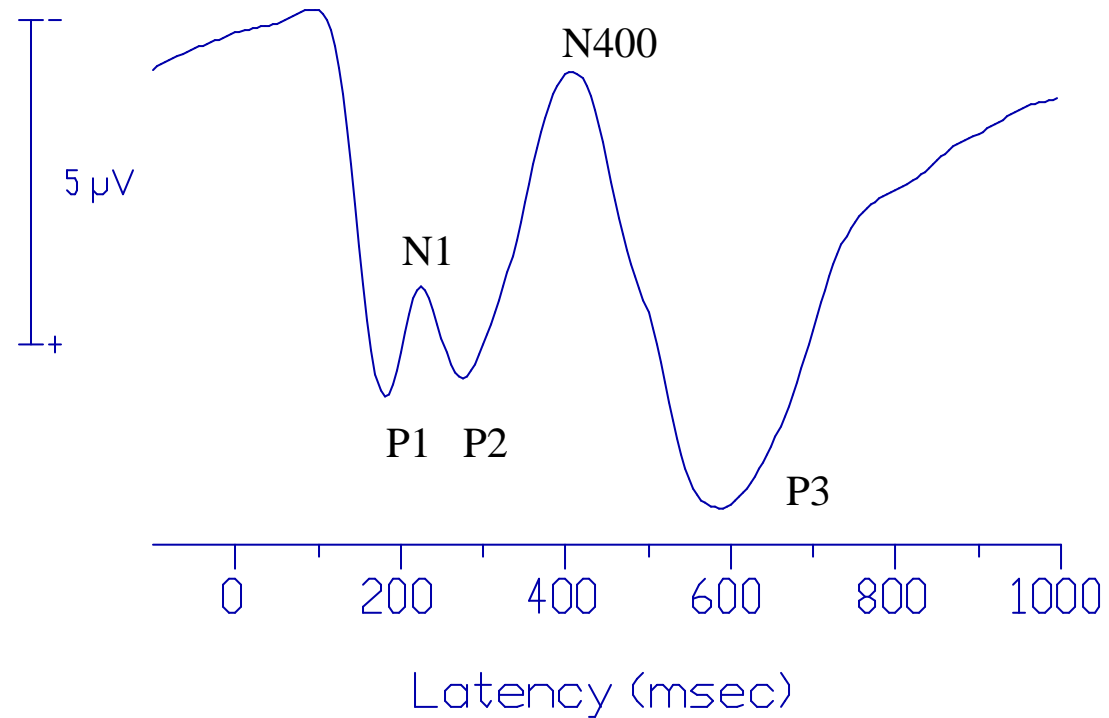

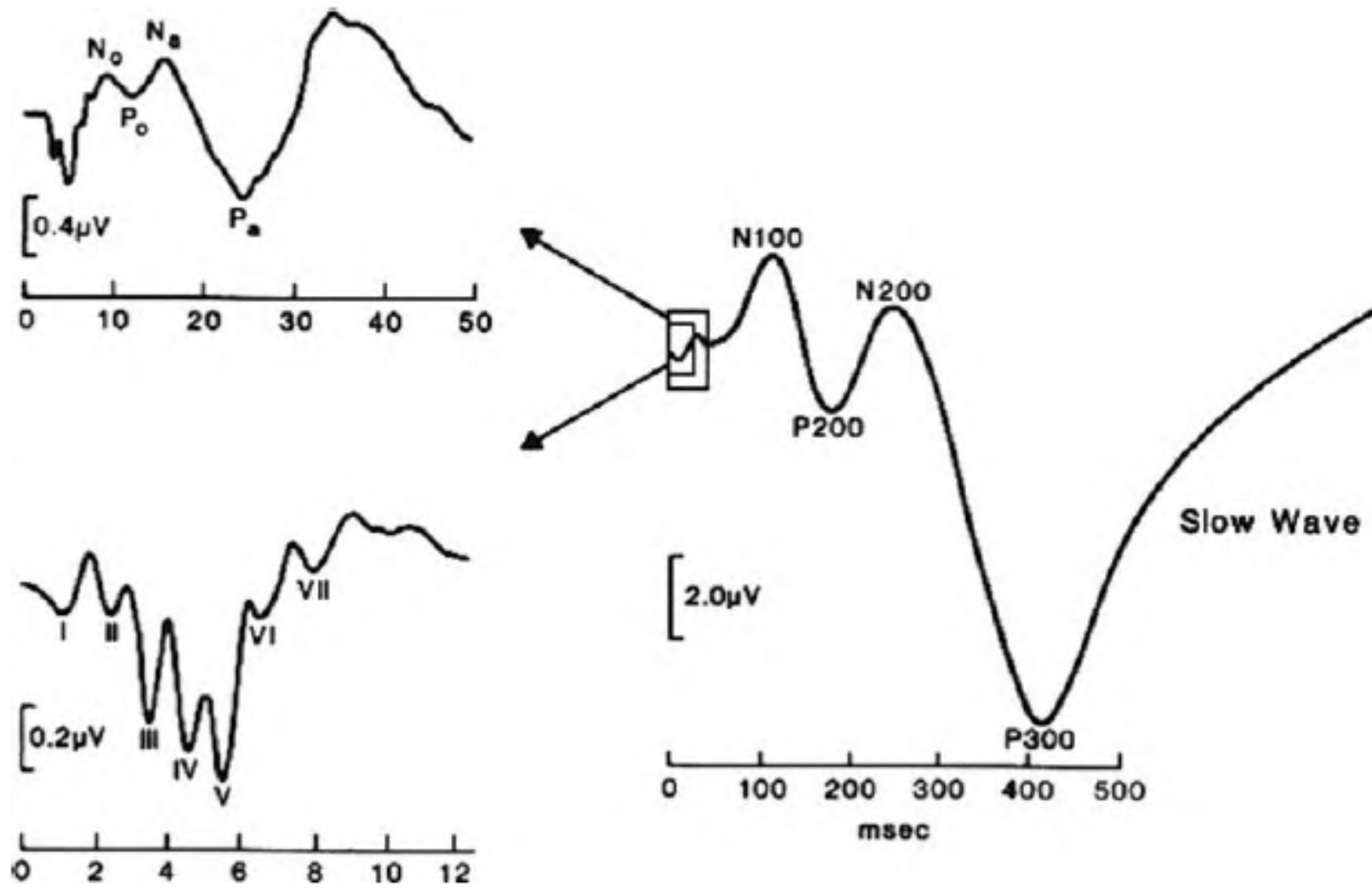
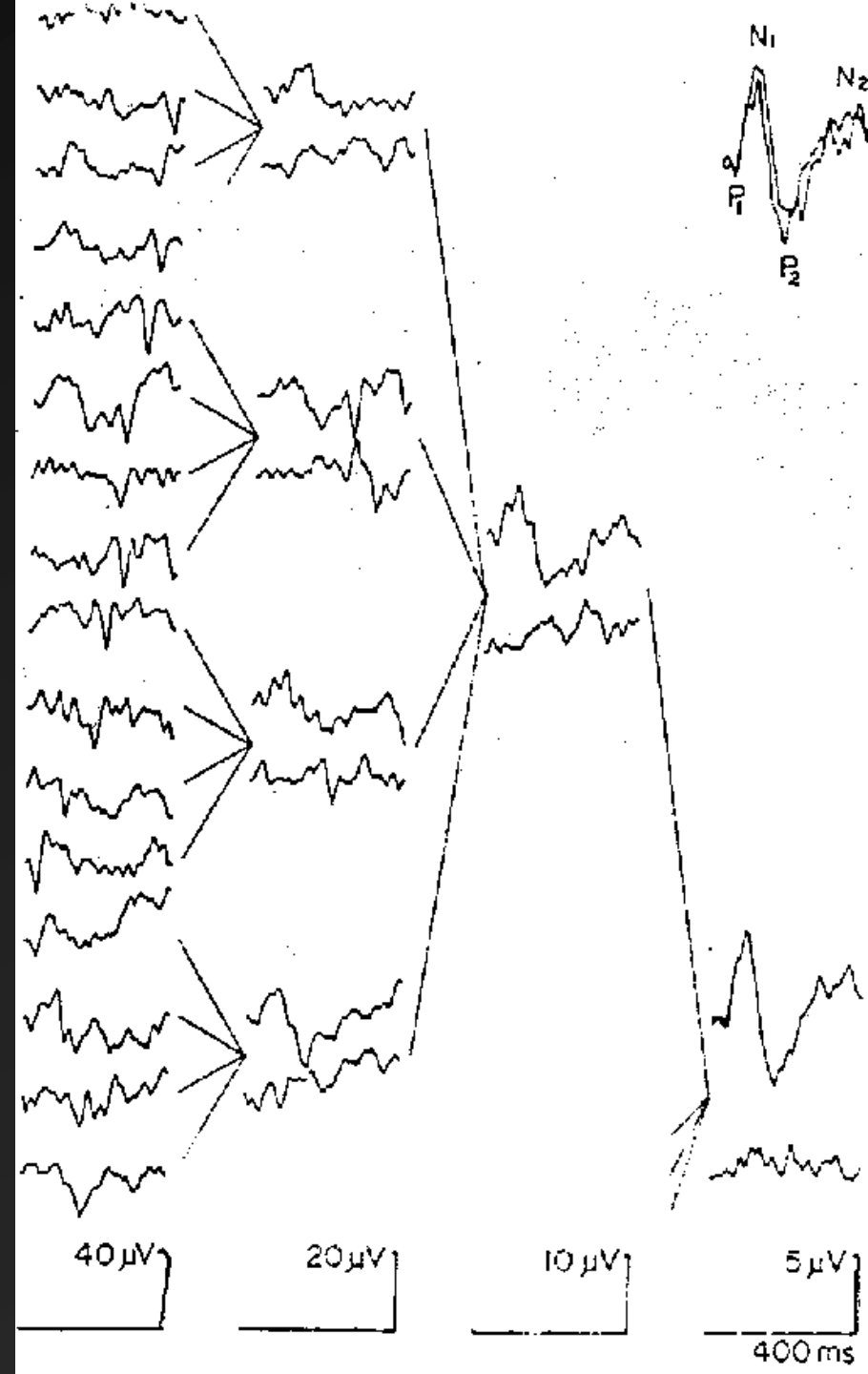

Figure 4.2. A schematic representation of ERP components elicited by auditory, infrequent target stimuli. The three panels represent three different voltage \times time functions: the left bottom panel shows the very early sensory components (with a latency of less than 10 ms); the left top panel shows the middle latency sensory components (with a latency of between 10 and 50 ms); and the right panel shows late components (latency exceeding 50 ms). Note the different voltage and time scales used in the three panels, as well as the different nomenclatures used to label the peaks (components). (Adapted with permission of the author from Donchin, 1979, with kind permission of Springer Science and Business media.)

Time-locked activity
and extraction by
averaging



The Classic View:

Time-locked activity and extraction by signal averaging

- Ongoing activity reflects "**noise**"
- Activity that reflects processing of a given stimulus "**signal**"
- The signal-related activity can be extracted because it is **time-locked** to the presentation of the stimulus
- Signal Averaging is most common method of extracting the signal
 - Sample EEG for ~1 second after each stimulus presentation & average together across like stimuli
 - Time-locked signal emerges; noise averages to zero
 - Signal to noise ratio increases as a function of the **square root** of the number of trials in the average

What does the ERP reflect?

- May reflect sensory, motor, **and/or** cognitive events in the brain
- Reflect the synchronous and phase-locked activities of large neuronal populations engaged in information processing

Component is a "bump" or "trough"

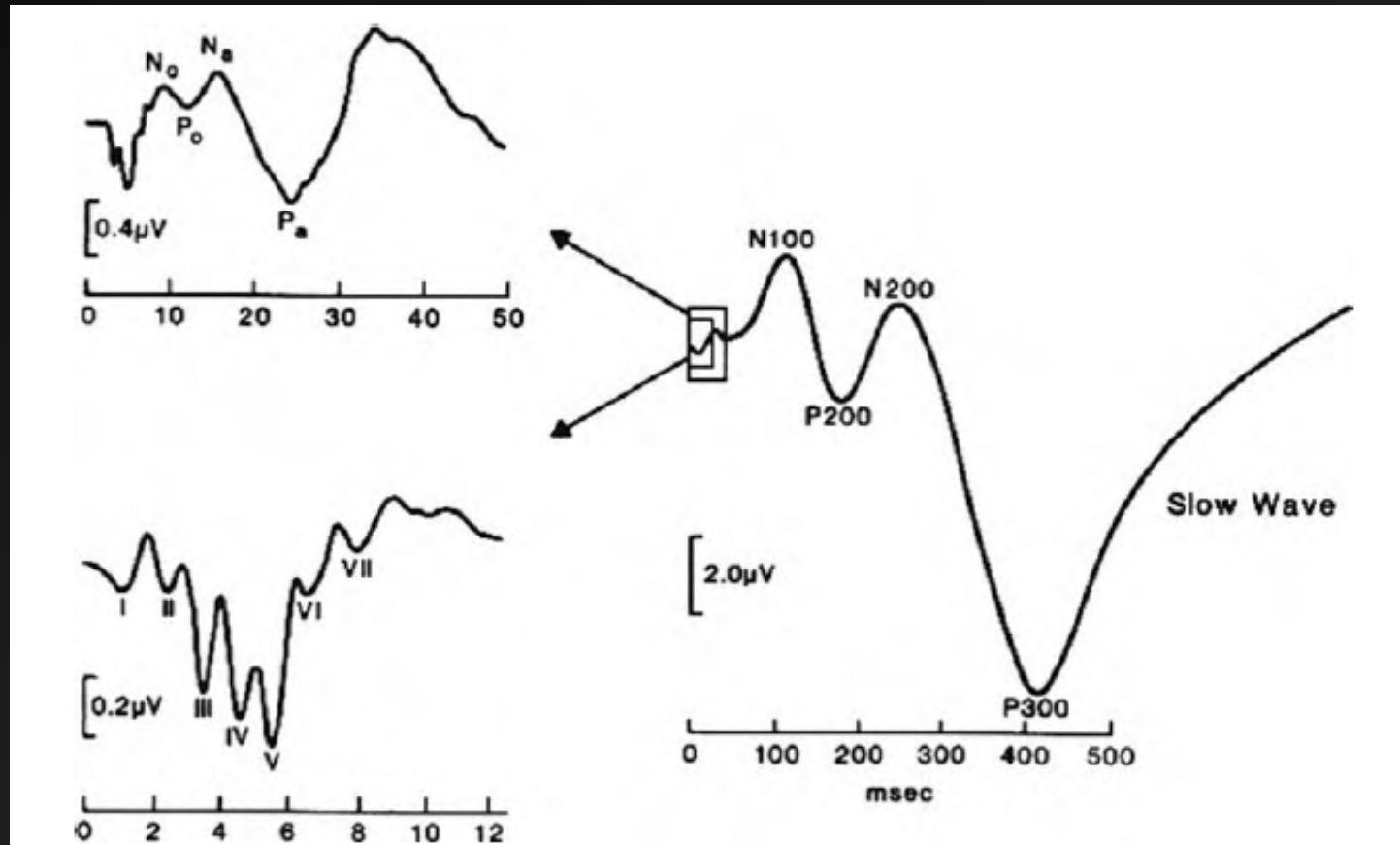
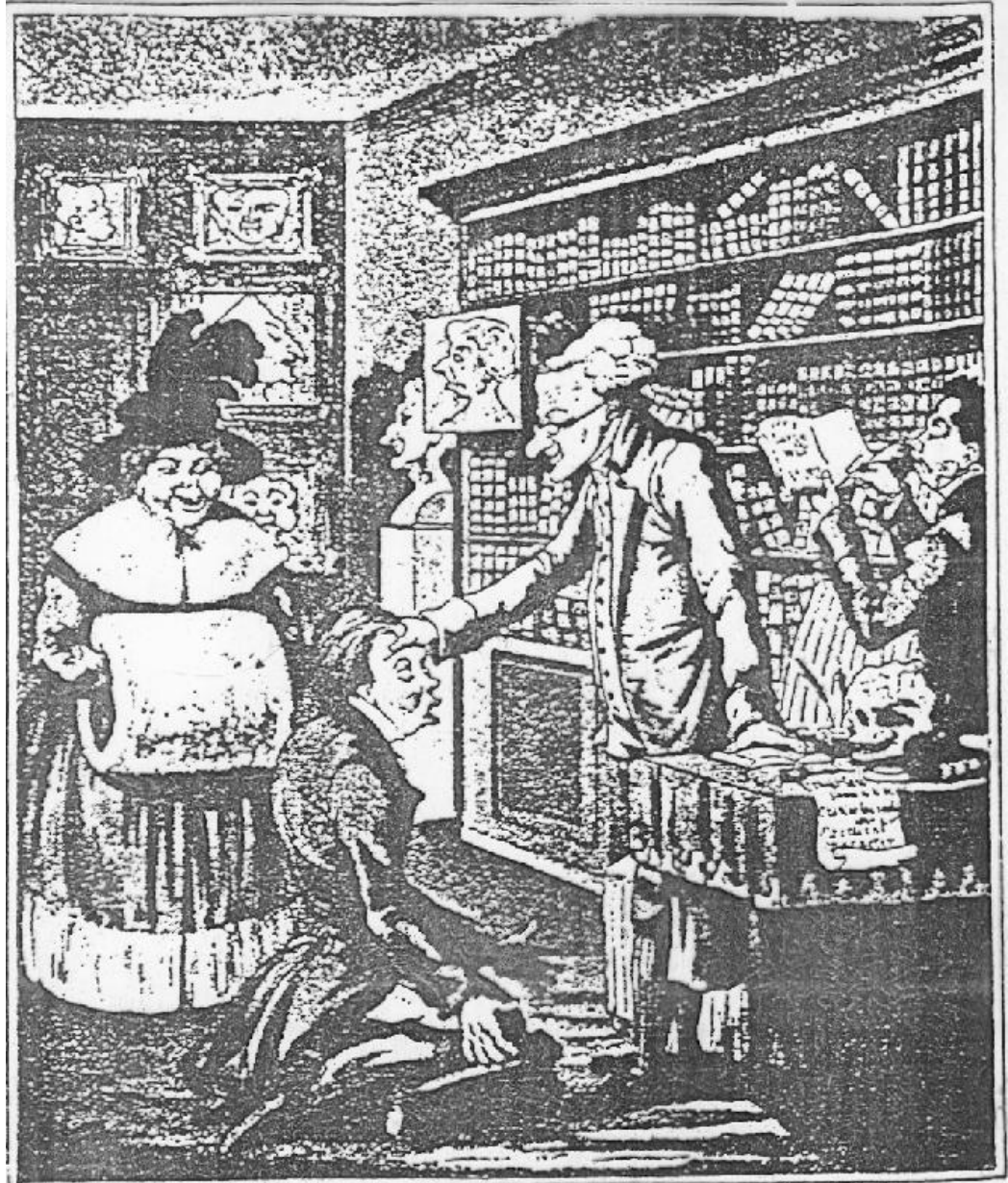

Figure 4.2. A schematic representation of ERP components elicited by auditory, infrequent target stimuli. The three panels represent three different voltage \times time functions: the left bottom panel shows the very early sensory components (with a latency of less than 10 ms); the left top panel shows the middle latency sensory components (with a latency of between 10 and 50 ms); and the right panel shows late components (latency exceeding 50 ms). Note the different voltage and time scales used in the three panels, as well as the different nomenclatures used to label the peaks (components). (Adapted with permission of the author from Donchin, 1979, with kind permission of Springer Science and Business media.)

Making Meaning from the bumps

Pores o'er the Cranial map with learned eyes,
Each rising hill and bumpy knoll decries
Here secret fires, and there deep mines of sense
His touch detects beneath each prominence.



R.T.D. Esq. del.
1856

Bumpology

Ed. 7th. 22nd 1856. 5. St. Paul's Churchyard
25 St. James's Place London

Pores o'er the Cranial map with learned eyes,
Each rising hill and bumpy knoll decries,
Here secret fires, and there deep mines of sense
His touch detects beneath each prominence.

Nomenclature & Quantifying

- Most commonly label peaks and troughs by polarity (P or N) and latency at active recording site
- Quantifying
 - Amplitude
 - Latency
 - Area
 - “String” measure
 - Fancy stuff to be discussed in “advanced” topics

Component is a "bump" or "trough"

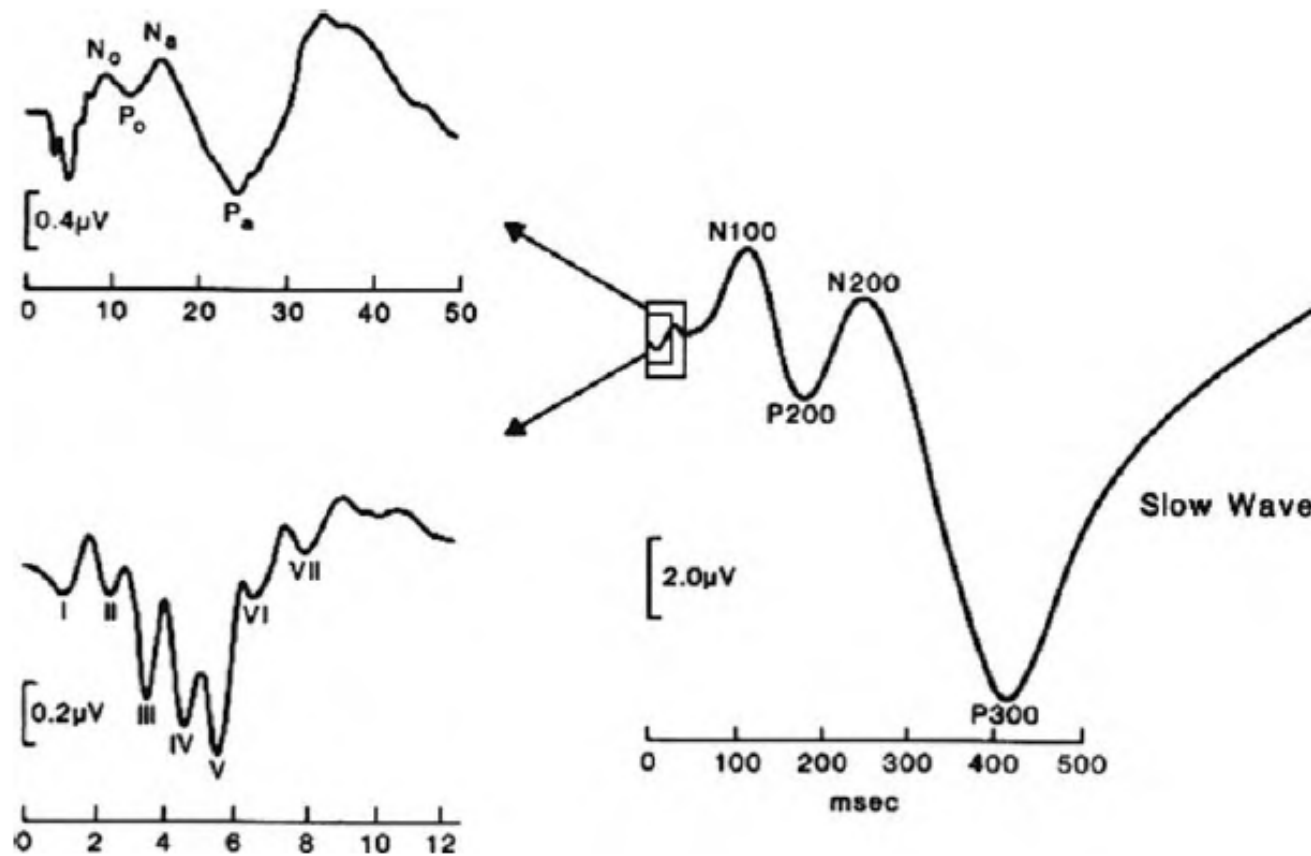

Figure 4.2. A schematic representation of ERP components elicited by auditory, infrequent target stimuli. The three panels represent three different voltage \times time functions: the left bottom panel shows the very early sensory components (with a latency of less than 10 ms); the left top panel shows the middle latency sensory components (with a latency of between 10 and 50 ms); and the right panel shows late components (latency exceeding 50 ms). Note the different voltage and time scales used in the three panels, as well as the different nomenclatures used to label the peaks (components). (Adapted with permission of the author from Donchin, 1979, with kind permission of Springer Science and Business media.)

Early Components

- Waves I-VI represent evoked activity in auditory pathways and nuclei of the brainstem
- Early components <60-100 msec
 - occur in **obligatory** fashion
 - are called **Exogenous** = determined "outside" organism
- Even subtle deviations in appearance may be indicative of pathology

Later ERP components

- Highly sensitive to changes in
 - State of organism
 - Meaning of stimulus (NOT physical characteristics)
 - Information processing demands of task
- Therefore termed **Endogenous** = determined “within” organism

Not all components fit neatly into
exogenous or endogenous categories

- Both Obligatory but modulated by
psychological factors
- “Mesogenous”

Defining Components:

aka how do I know one when I see one?

- By positive and negative peaks at various latencies and scalp locations
- By functional associations, covarying across subjects, conditions, or scalp locations in response to experimental manipulations
- By neuronal structures that plausibly give rise to them

Evoked Vs Emitted ERP's

- Evoked are most commonly studied: occur in response to a physical stimulus
- Emitted potentials occur in absence of a physical stimulus (e.g., omission of item in sequence)
- Evoked can have both exogenous and endogenous components; emitted usually have only endogenous

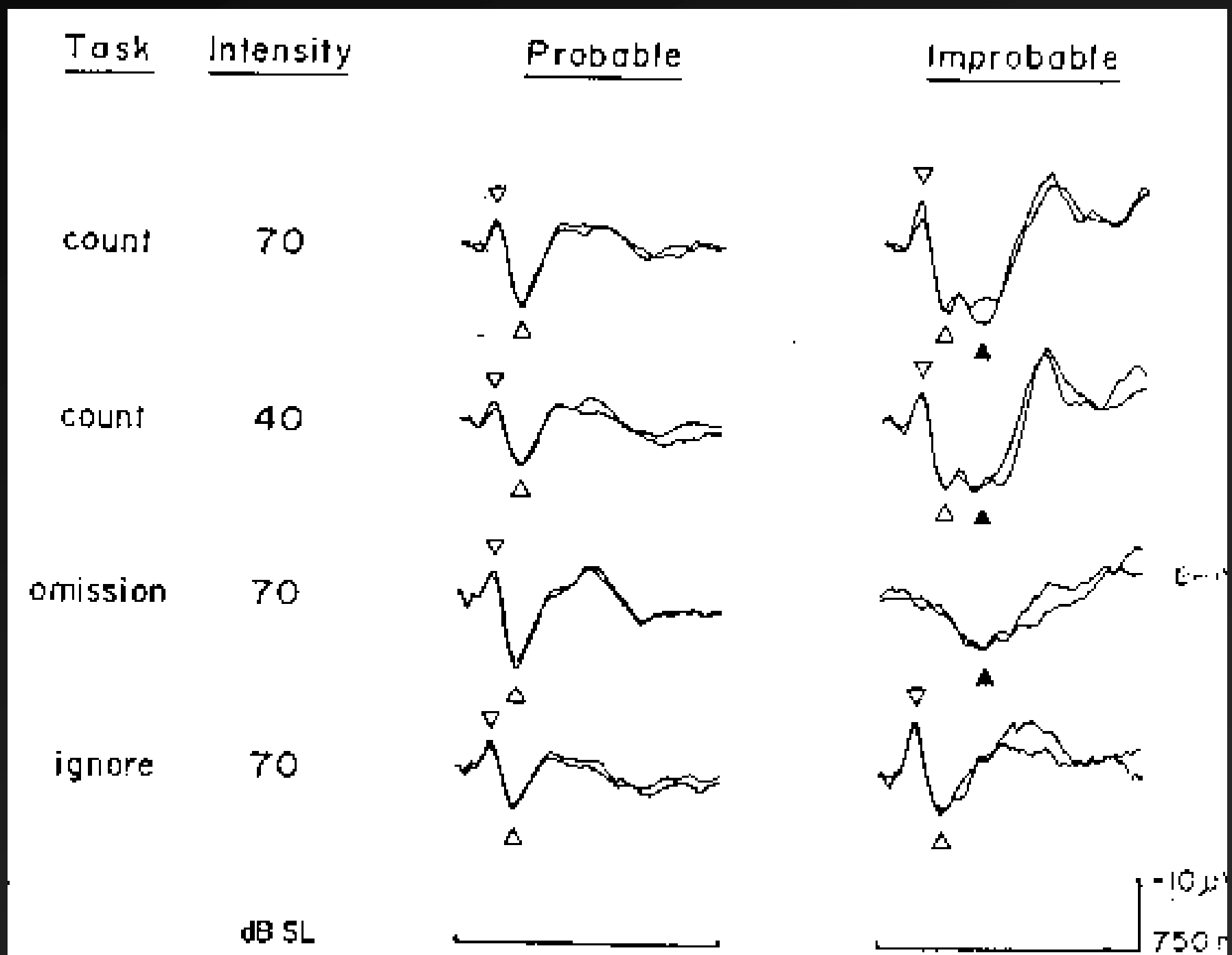

Comparison to other "windows on the brain"

- Very precise temporal resolution

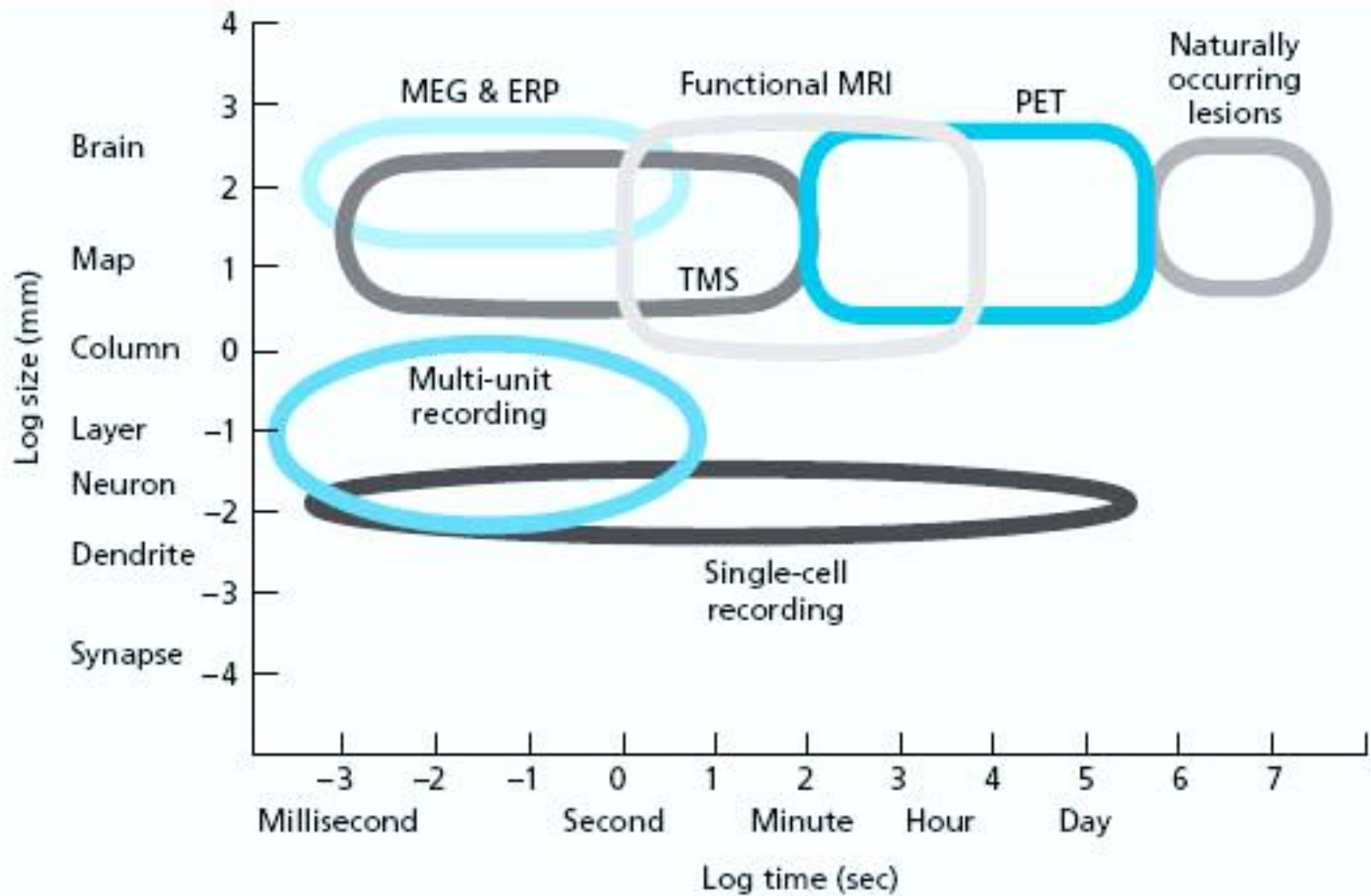

Comparison to other "windows on the brain"

- Very precise temporal resolution
- Spatial localization is more difficult
 - At the surface, activity of many functional synaptic units recorded
 - ERP's generated only by groups of cells that are synchronously activated in a geometrically organized manner

OPEN FIELD

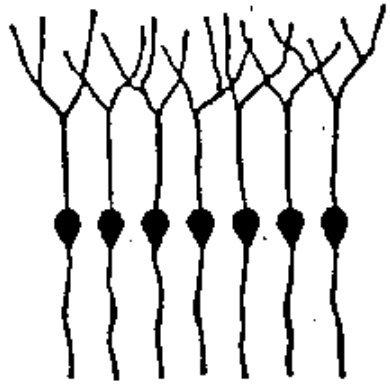

CLOSED FIELD

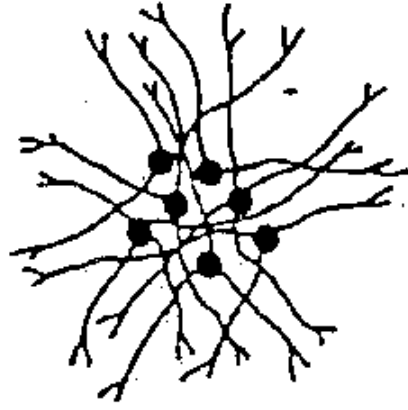

OPEN-CLOSED FIELD

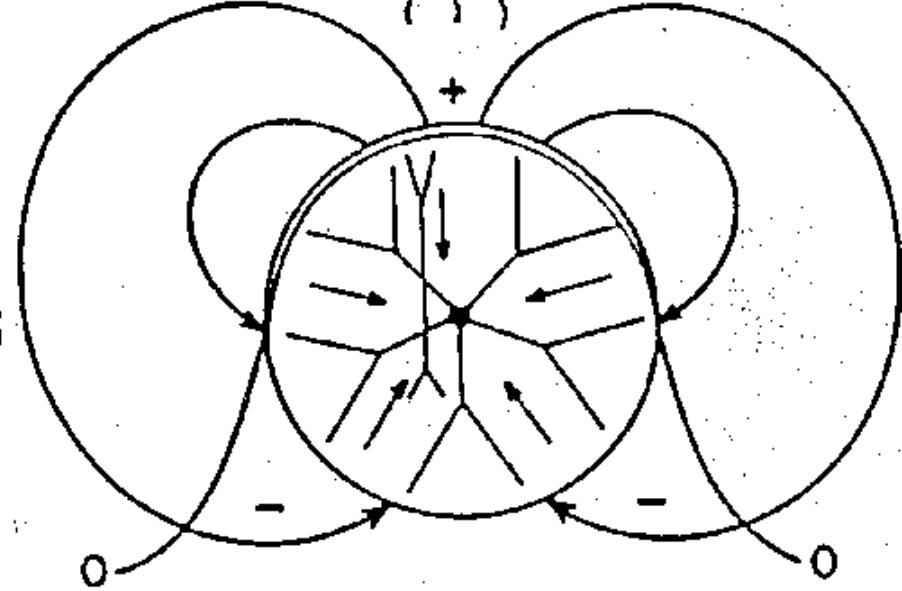
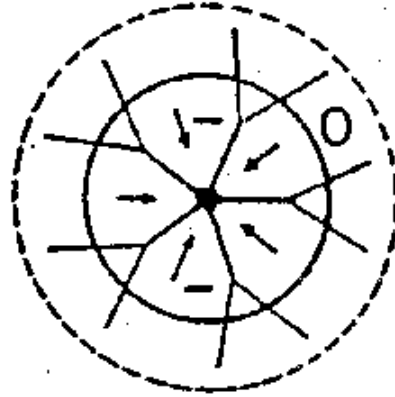
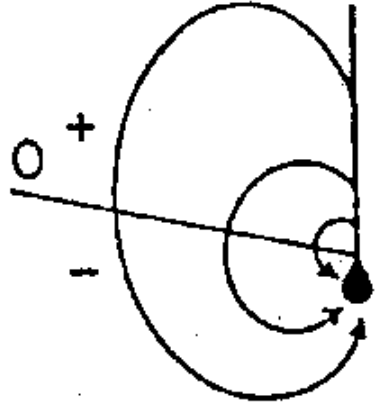
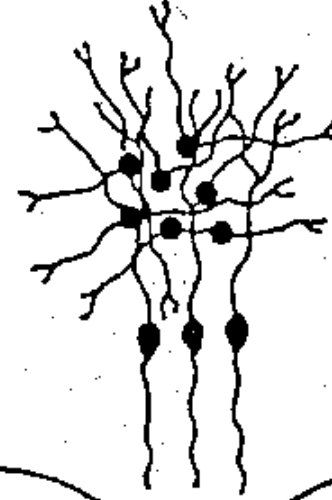

After Lorente de Nó, 1947

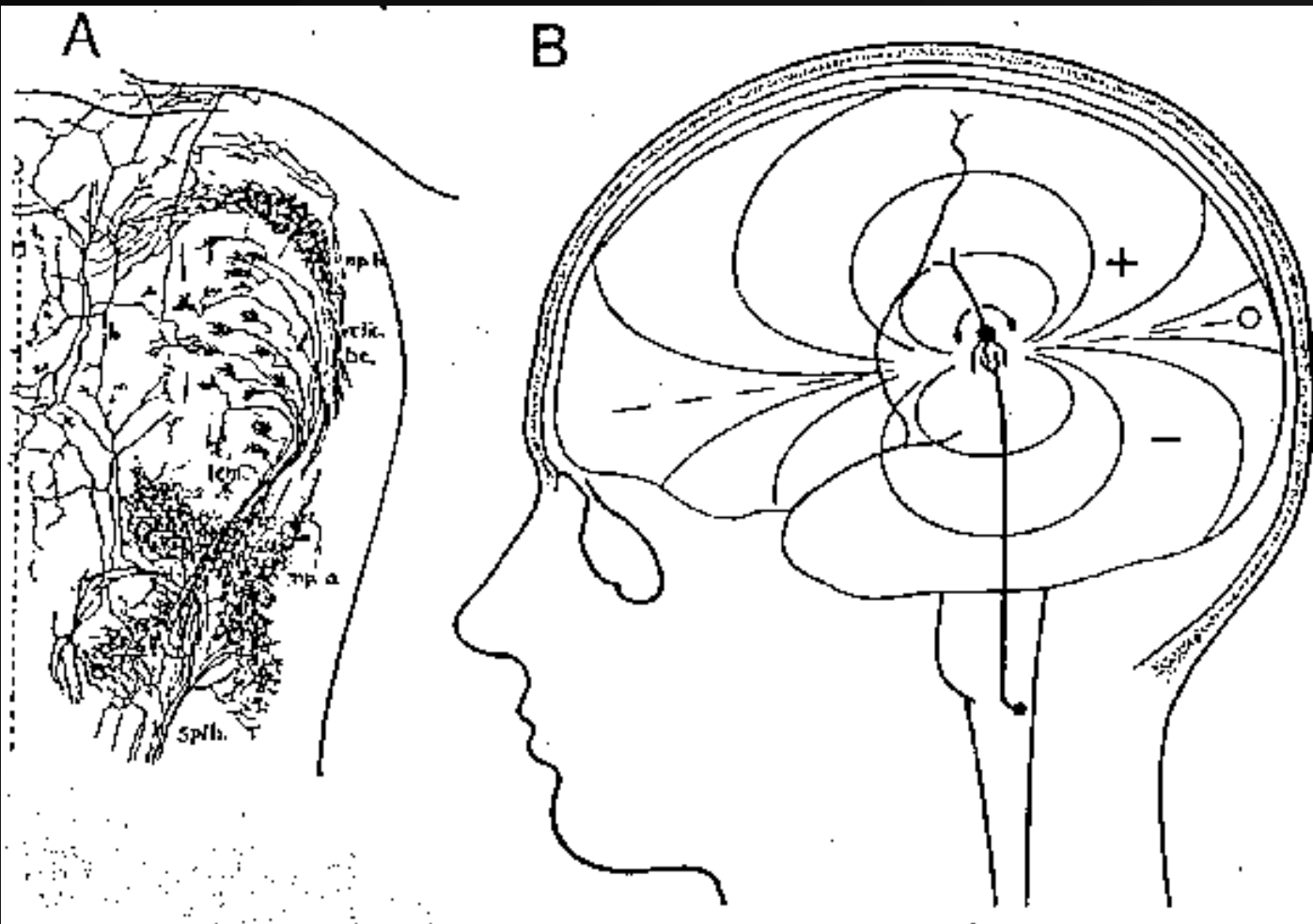

Figure 1-11. Anatomy and electrogenesis of ventroposterior (VP) thalamus. A. Horizontal section showing bushy arborizations of lemniscal (lem) afferents terminating on dendrites of VP relay neurons (g). (From "Patterns of Organization in Specific and Non-specific Thalamic Fields" by M. E. Scheibel and A. B. Scheibel. In D. P. Purpura and M. D. Yahr [Eds.], *The Thalamus*. New York: Columbia University Press, 1966. Reprinted by permission.) B. Postulated potential field produced by depolarization of VP relay neurons. For clarity, the most intense parts of the field are omitted.

Comparison to other "windows on the brain"

- Very precise temporal resolution
- Spatial localization is more difficult
 - At the surface, activity of many functional synaptic units recorded
 - ERP's generated only by groups of cells that are synchronously activated in a geometrically organized manner
 - Synchronous activation may occur in one or more than one location
 - Monopolar recording technique most often used
 - Yet localization is not impossible in conjunction with other techniques

Caveat Emptor

- DO NOT interpret scalp distribution of ERP's as reflect cortical specialization
- Also, DO NOT interpret area of maximum amplitude to suggest that generator lies underneath

Correlate Vs substrate (AGAIN)

- Late ERP components should not be taken to indicate the existence of a neurological substrate of cognitive processing
- Rather should be considered a correlate
- Constructs in search of validation; Process of validation:
 - Determine antecedent conditions under which the ERP component appears and also magnitude and latency of ERP component
 - Develop hypotheses concerning functional significance of the "subroutine" underlying the ERP component
 - Predict consequences of subroutine--validate empirically

CRANIOLOGY



What a charming field for Scientific Observation.

Basic Signal Processing

Paradigms and acquisition

- Precise temporal control over stimulus presentation necessary
 - Requires discrete stimuli or responses
- Individual stimuli are presented numerous times; ERP's generally do not habituate, unlike peripheral measures
- Concurrent with each stimulus, a signal/pulse must be sent to the A/D converter to indicate time of stimulus onset
- Sampling epochs (legacy!) vs continuously
 - Considerations for sampling epochs
 - pre-onset samples (to provide a baseline for comparison)
 - **epoch length**
- Epochs for like stimuli averaged together to create ERP for that set of stimuli

Assumptions of Averaging methods

- Signal and noise (in each epoch) sum linearly together to produce the recorded waveform for each epoch (not some peculiar interaction)
- The evoked signal waveshape attributable **solely** to the stimulus is the same for each presentation
- The noise contributions can be considered to constitute statistically independent samples of a random process

Demo of Averaging

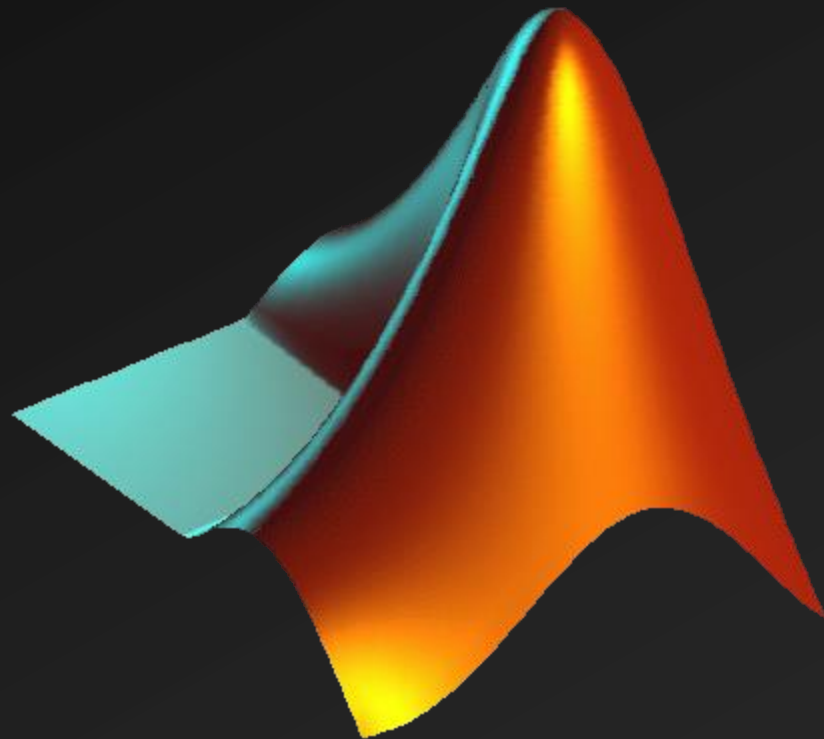

Filtering and its influence on the ERP

- Despite many trials and averaging, some noise may remain in the averaged waveform
- If you are only interested in later & slower components, then a low-pass filter may be of interest

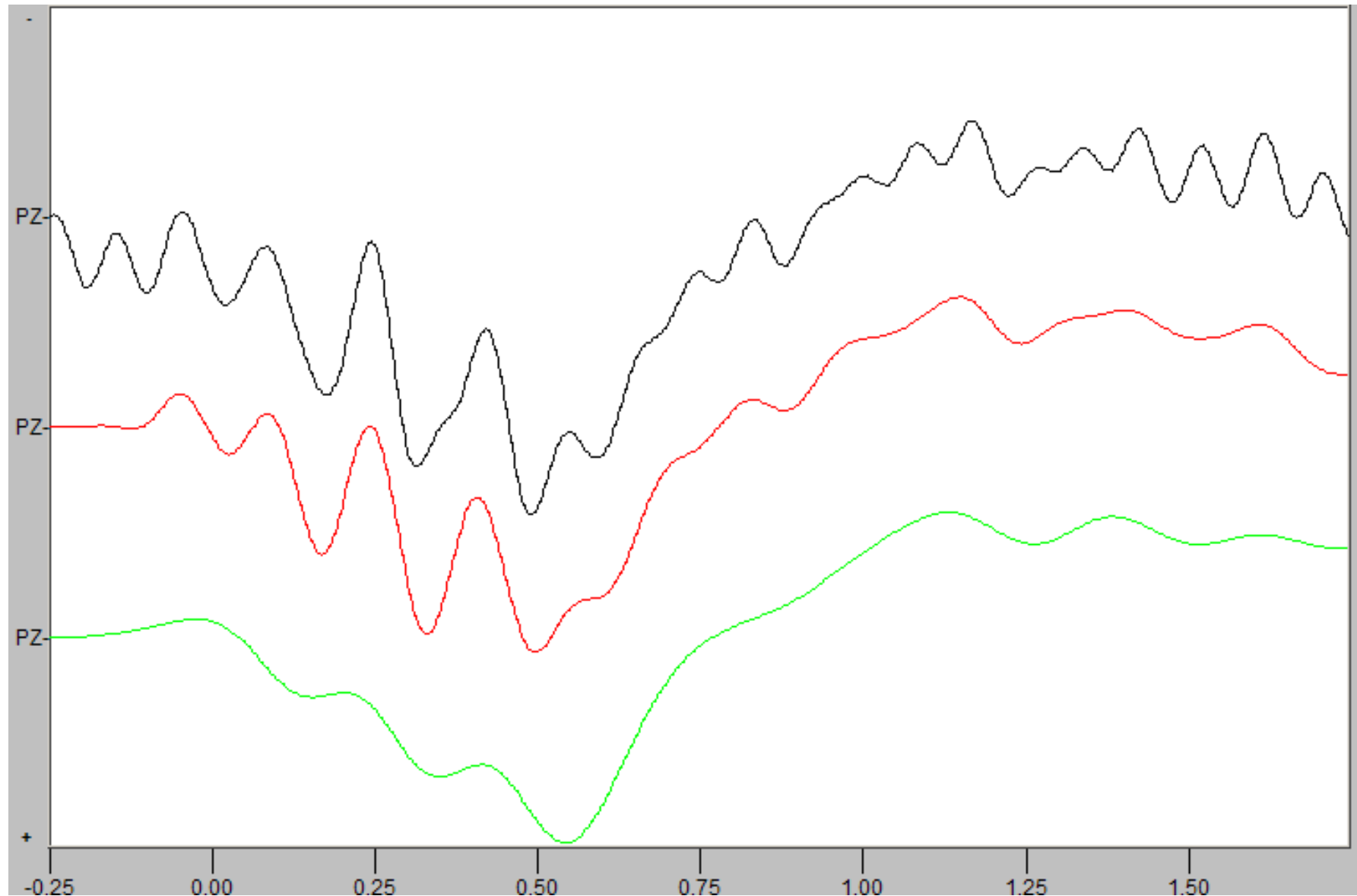

Same ERP filtered with 12.5 (black), 8 (red) , and 5 (lime) Hz Low Pass FIR Filter

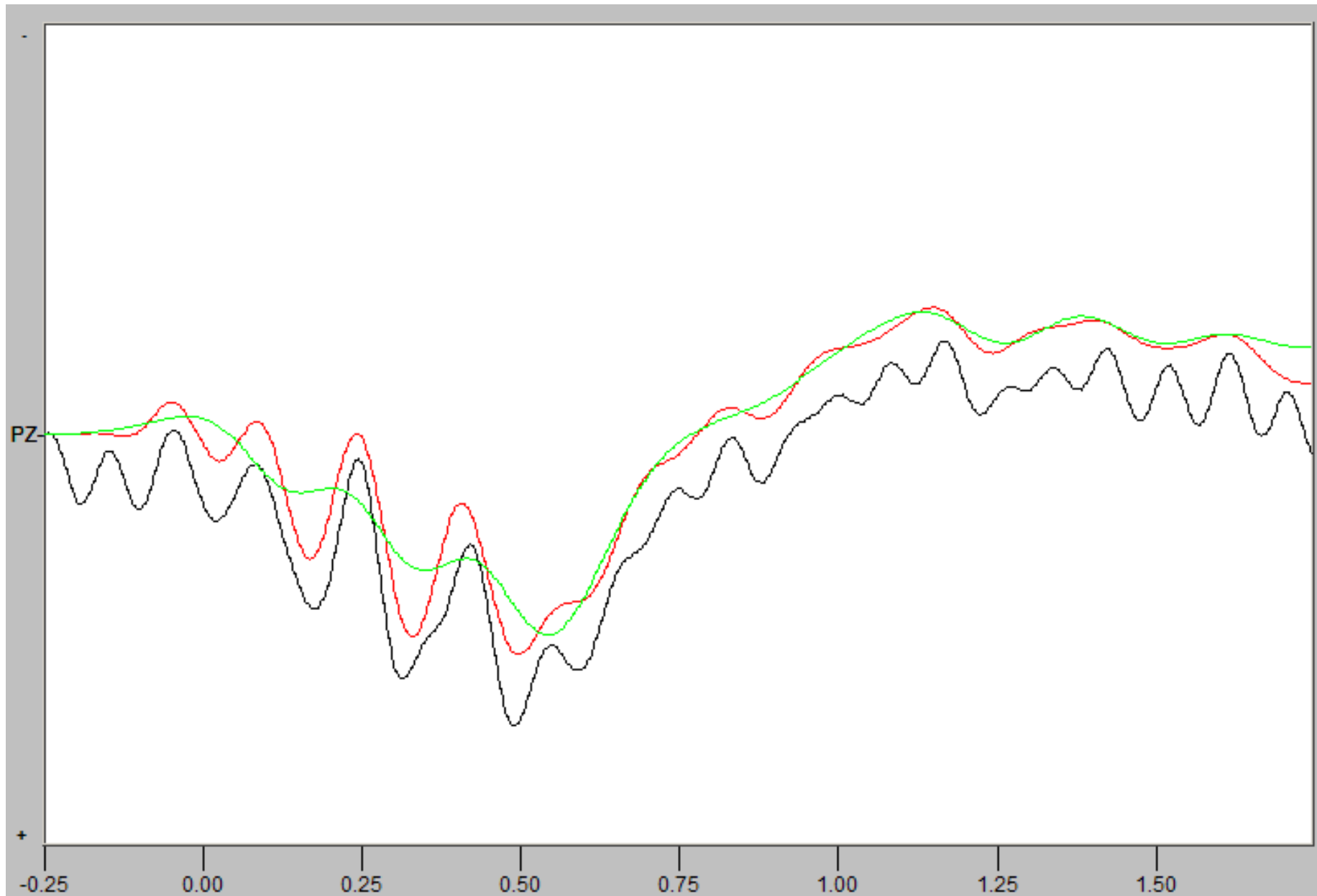

Same ERPs overlaid; note amplitude attenuation in P3 amplitude with stricter filters

Let's ERP!

Applications of Early Components

- Neurological evaluation of sensory function; e.g. evaluation of hearing in infants
 - Tones of various dB intensities presented and V wave in auditory brainstem ERP examined
 - **Figure 10**; 4000 individual trials per average

Left Ear

Right Ear

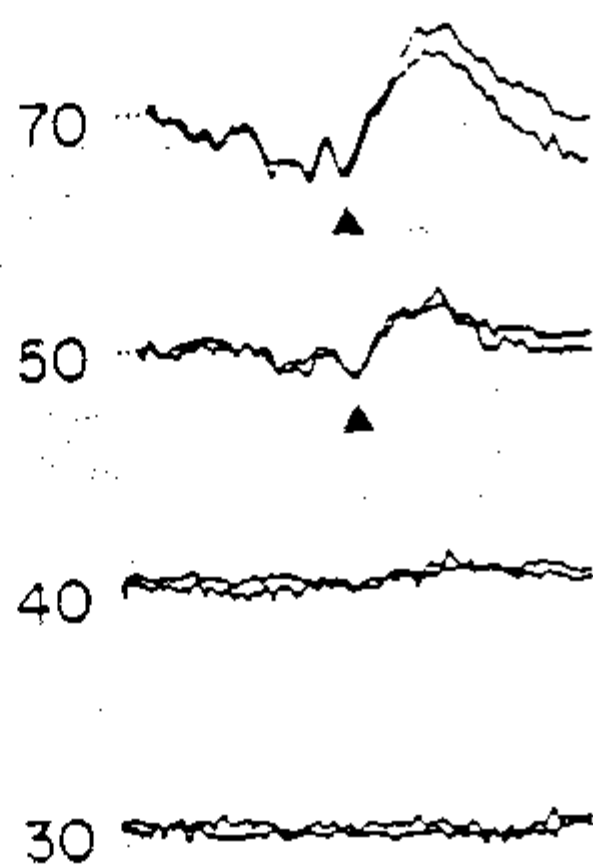
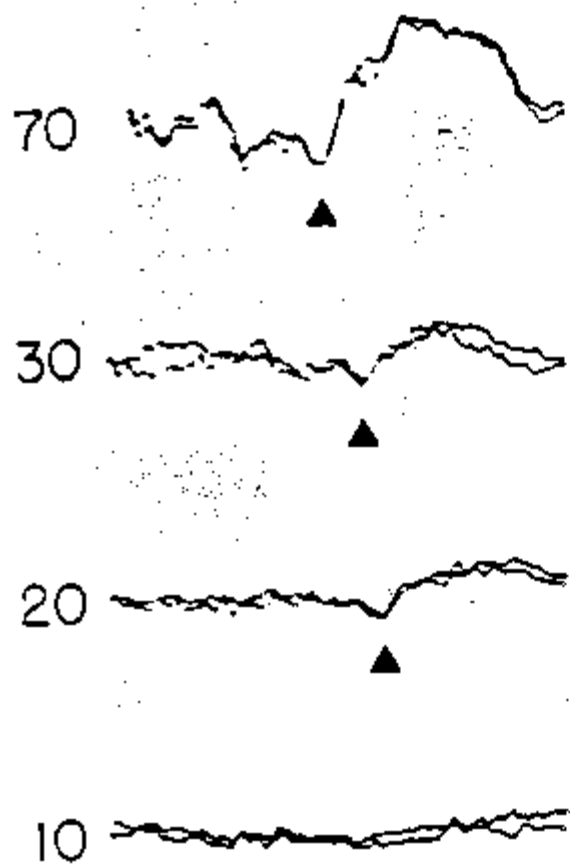

dBnHL

-0.5 μ V

15 ms

Prediction of recovery from coma

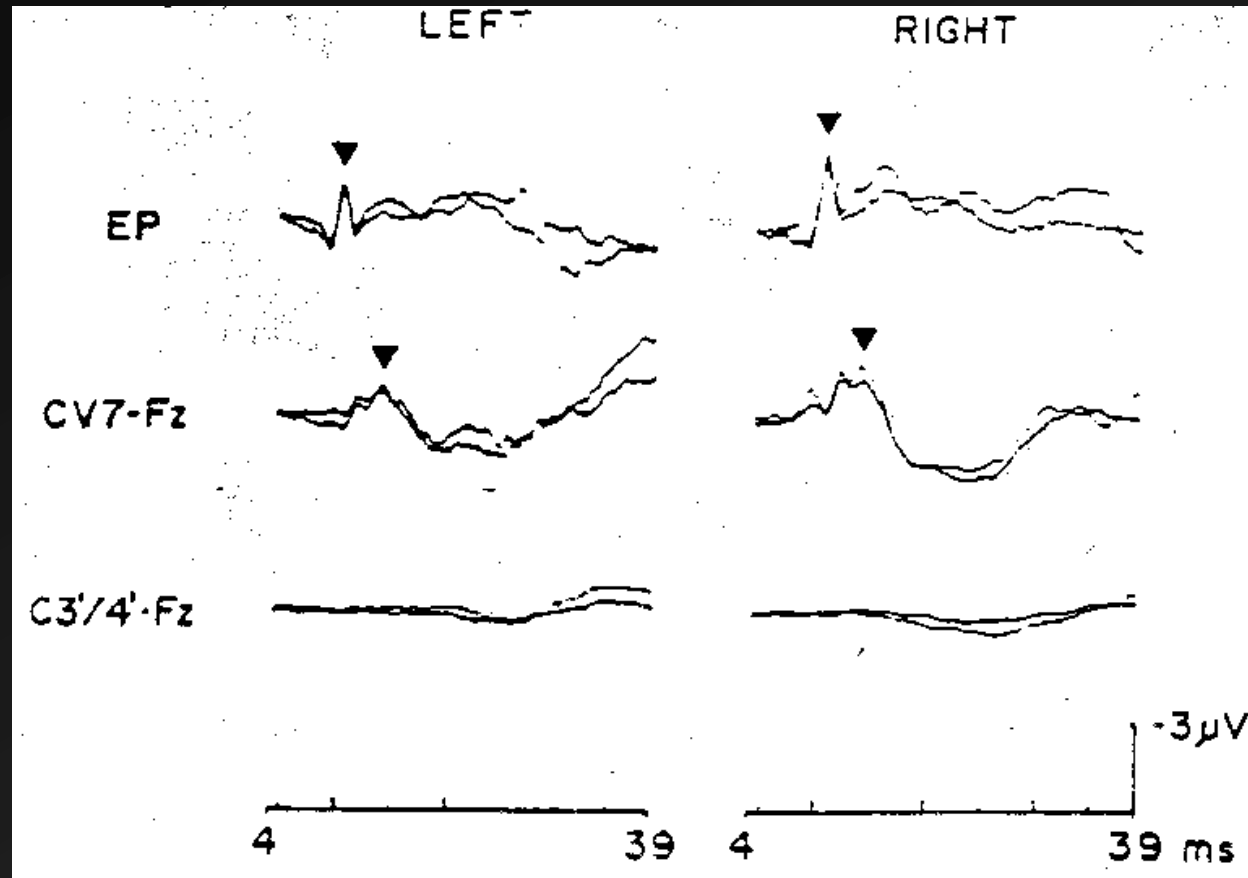

- ❑ Somatosensory evoked potentials were recorded from a patient who was still comatose 1 week after severe closed head injury.
- ❑ Responses evoked by electrical stimulation of left and right median nerves
- ❑ Normal tracing seen at Erb's point, and from the next over vertebra prominens, but not over C3' of C4'.
- ❑ Absence of any cortical response a bad prognostic sign. Patient continued in a chronic vegetative state 1 year after accident

Inter-Hemispheric Transfer Time (IHTT)

- Hypothesized that interhemispheric transfer of information may be abnormal in various disorders (e.g., dyslexia)
- Reaction Time measures contain too much variability not related to Transfer Time
- ERP early components appear promising as a measure of time required to transfer information between hemispheres

IHTT Study (Saron)

- Checkerboards subtending < 1 degree of visual angle presented 2.9 degrees from center
- ERP's recorded at O1 and O2
- Problem of lateralization and Paradoxical results possible; parafoveal regions on banks of calcarine fissure
- P100 wave latency examined; earlier latency in occiput contralateral to presentation
 - Measured by peak picking procedure
 - Also by cross-lagged correlation technique
 - Both methods suggest ~15 millisecond IHTT; found to be in expected direction predicted by anatomy for over 90% of subjects
 - Reaction time data from same task showed no reliable differences

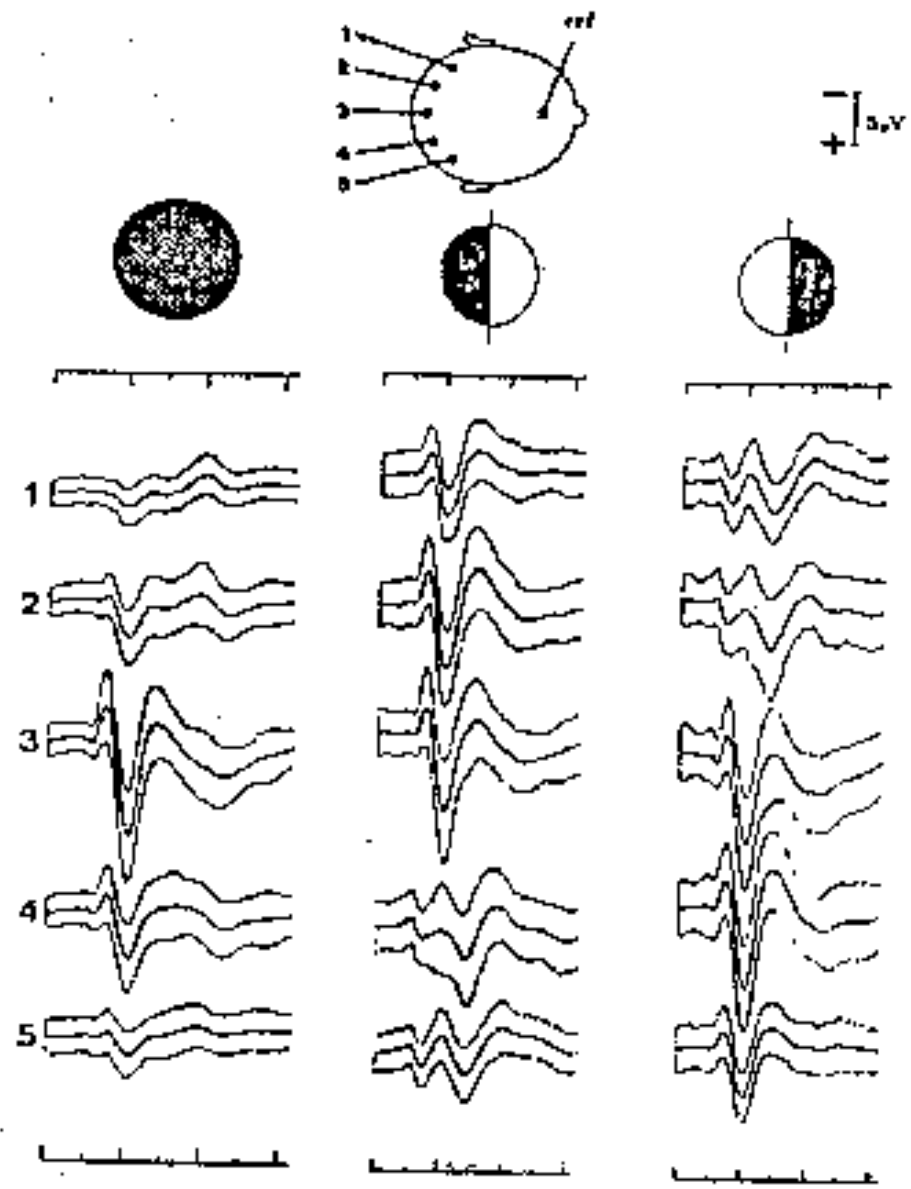
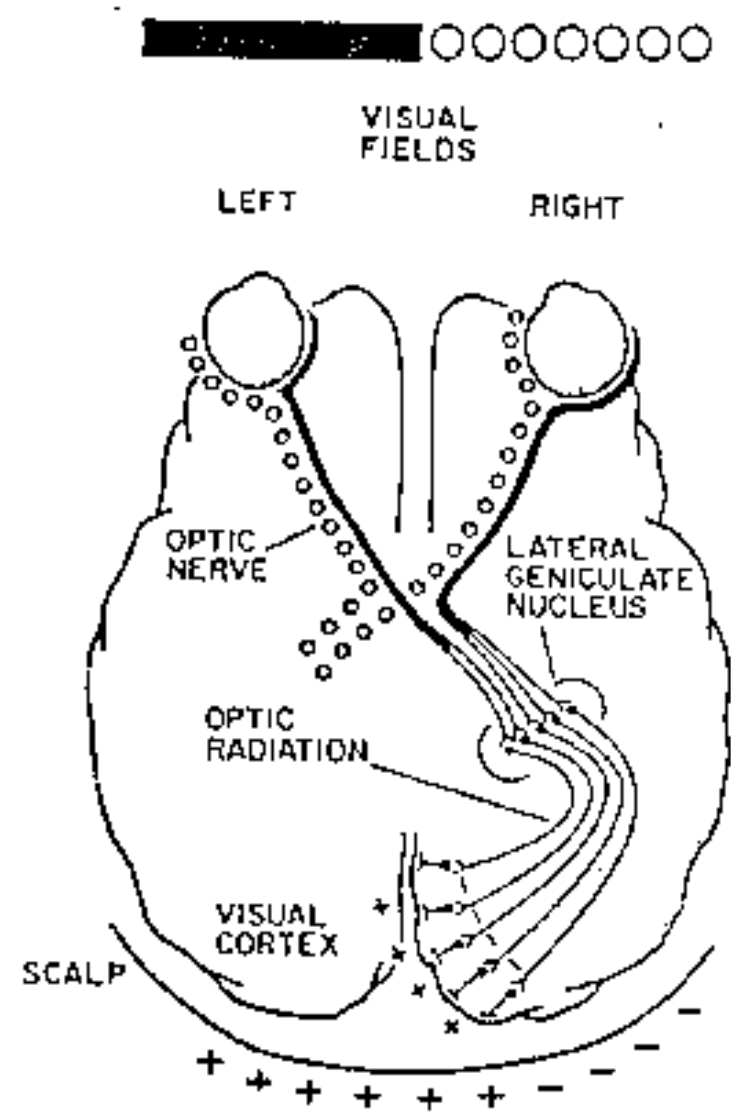
A**B**

P1, N1, and Attention

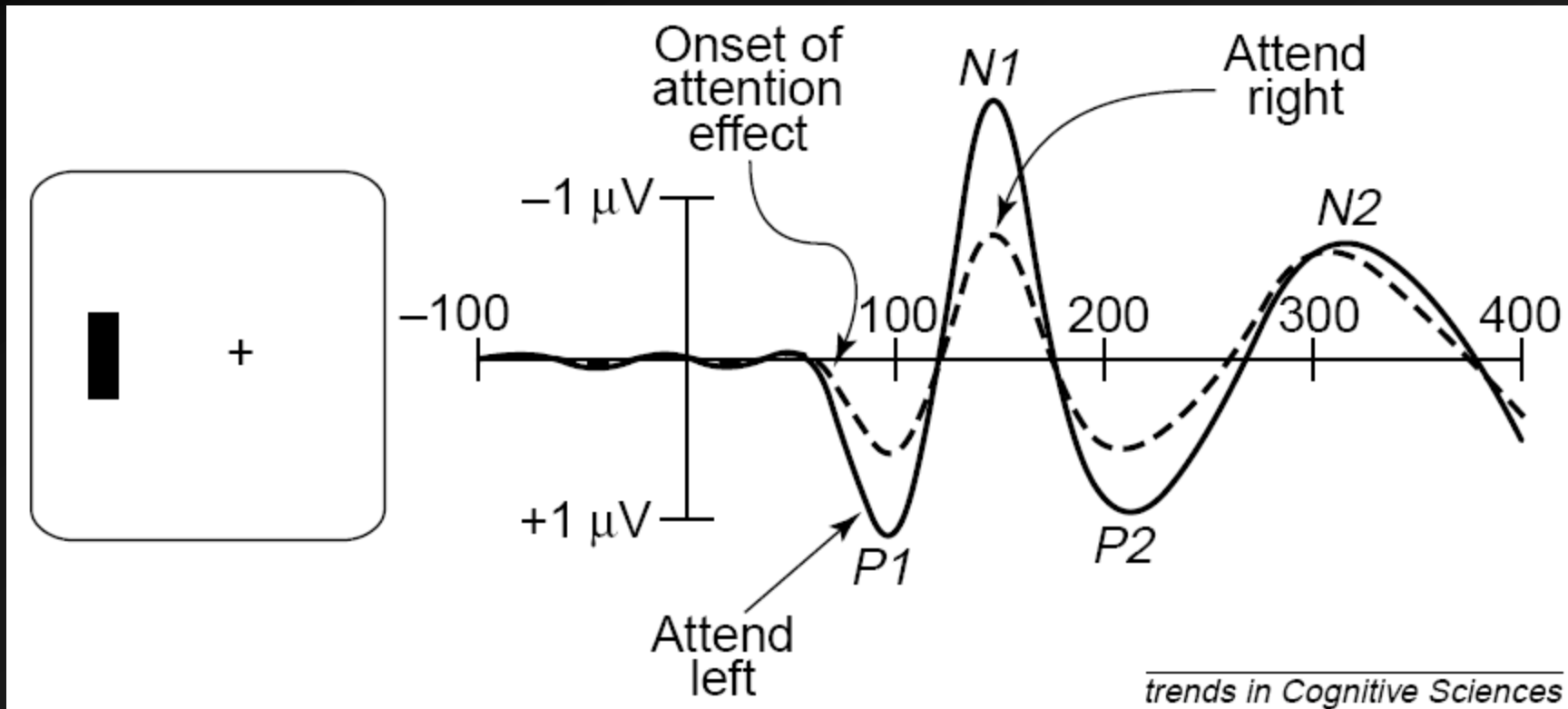

Fig. 1. Paradigm for using ERPs to study attention. Stimulus display (left) and idealized results (right). Subjects fixate a central cross and attend either to the left or right visual field. Stimuli are then presented to the left and right visual fields in a rapid sequence. In this example, the ERP elicited by a left visual field stimulus contains larger P1 and N1 components when the stimulus is attended ('Attend left') than when it is ignored ('Attend right').

More than Spatial Directed Attention

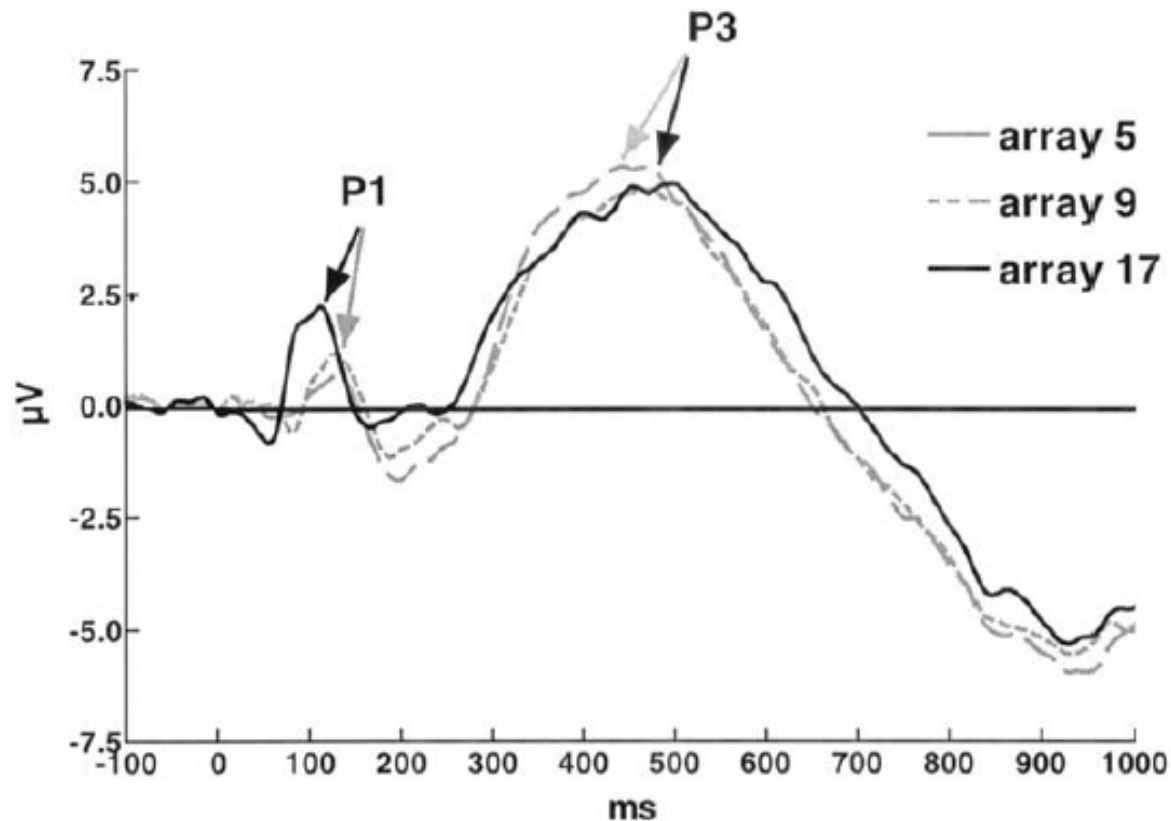

Fig. 2. Grand averaged visual ERPs at Pz electrode for the 3 array sizes, showing the shorter latencies, larger P1s for array size 17, but longer latency P3 (dark arrows) than for array sizes 5 and 9 (grey arrows). These are averaged across colour, orientation and conjunction conditions, as this ERP effect was seen regardless of whether it was a single feature or conjunction trial.

Increases stimulus complexity results in more rapid early processing

Note:
Amplitude of P1
Latency of P1
Latency of N1

Taylor
Clinical Neurophys
2002

More than Spatial Directed Attention

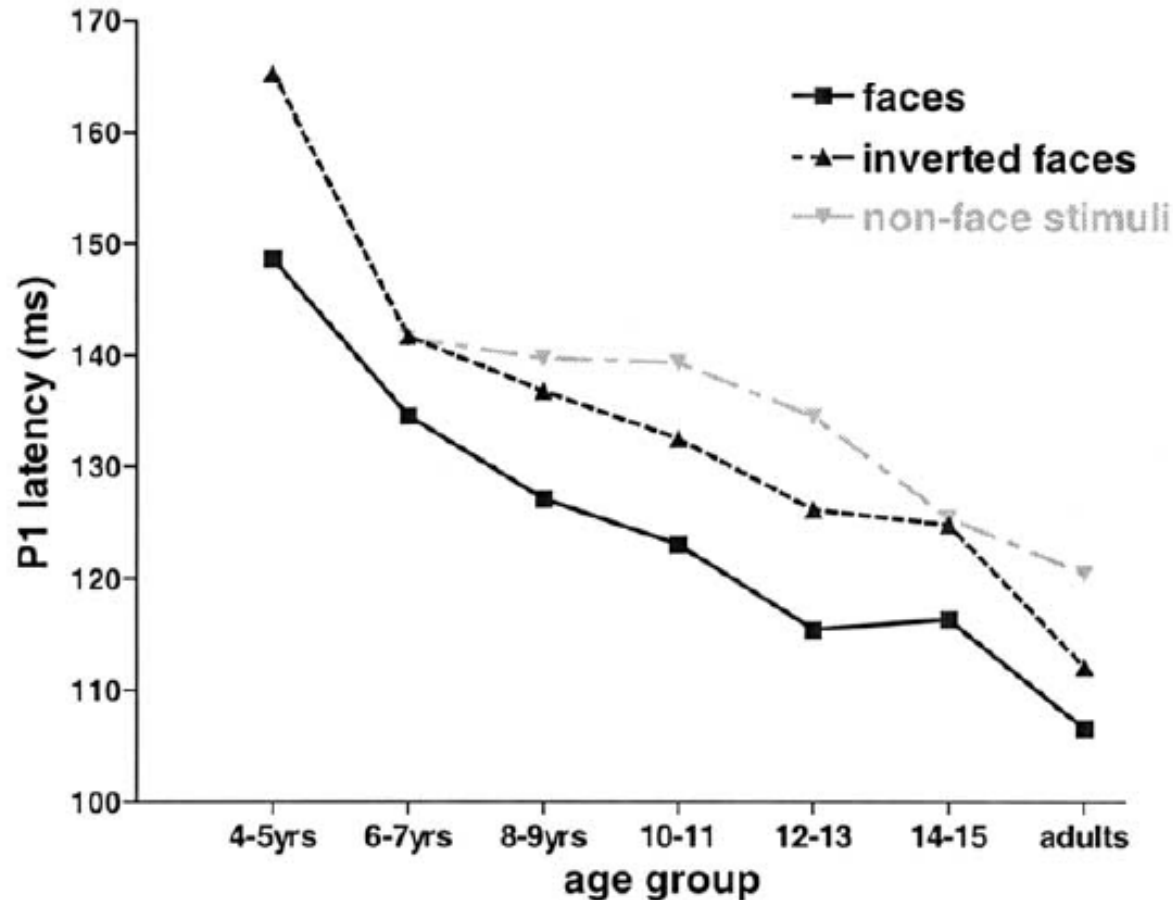
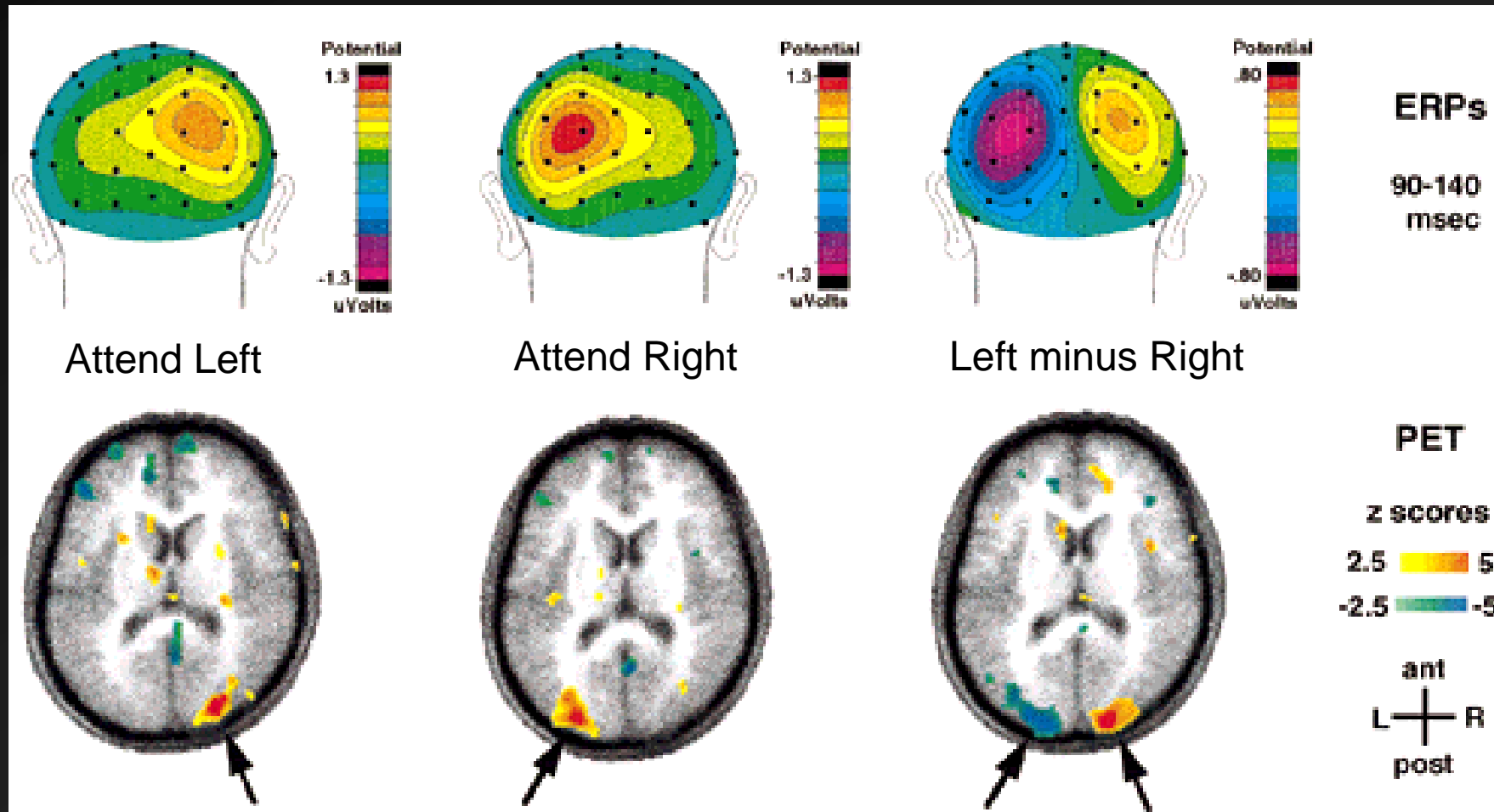

Fig. 3. Mean P1 latencies across 7 age groups, showing the consistently shorter latencies to faces compared to inverted faces and control stimuli (phase-scrambled faces and flowers). There were 15 children in each of the 6 age groups and 38 adults (adapted from Taylor et al., 2001c).

Taylor
Clinical Neurophys
2002

“These combined PET/ERP data therefore provide strong evidence that sustained visual spatial attention results in a preset, top-down biasing of the early sensory input channels in a retinotopically organized way”



Prelude to Advance Topic: Source Localization

Observed Potentials

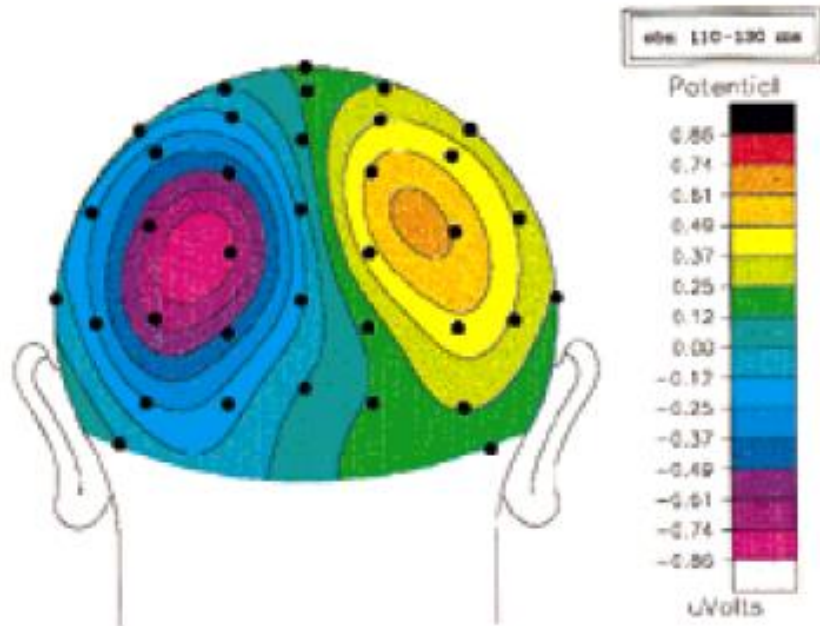

Model Potentials Dorsal Occipital PET Seeds

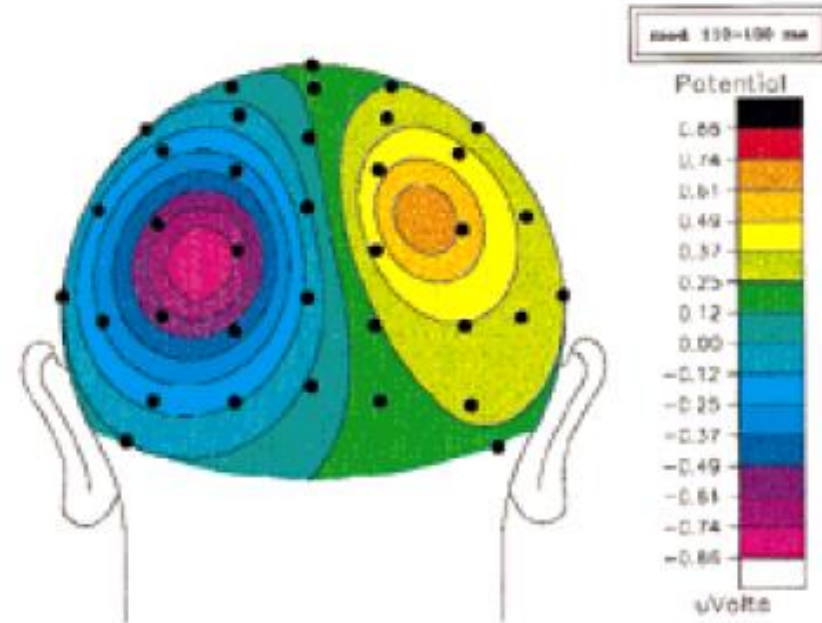
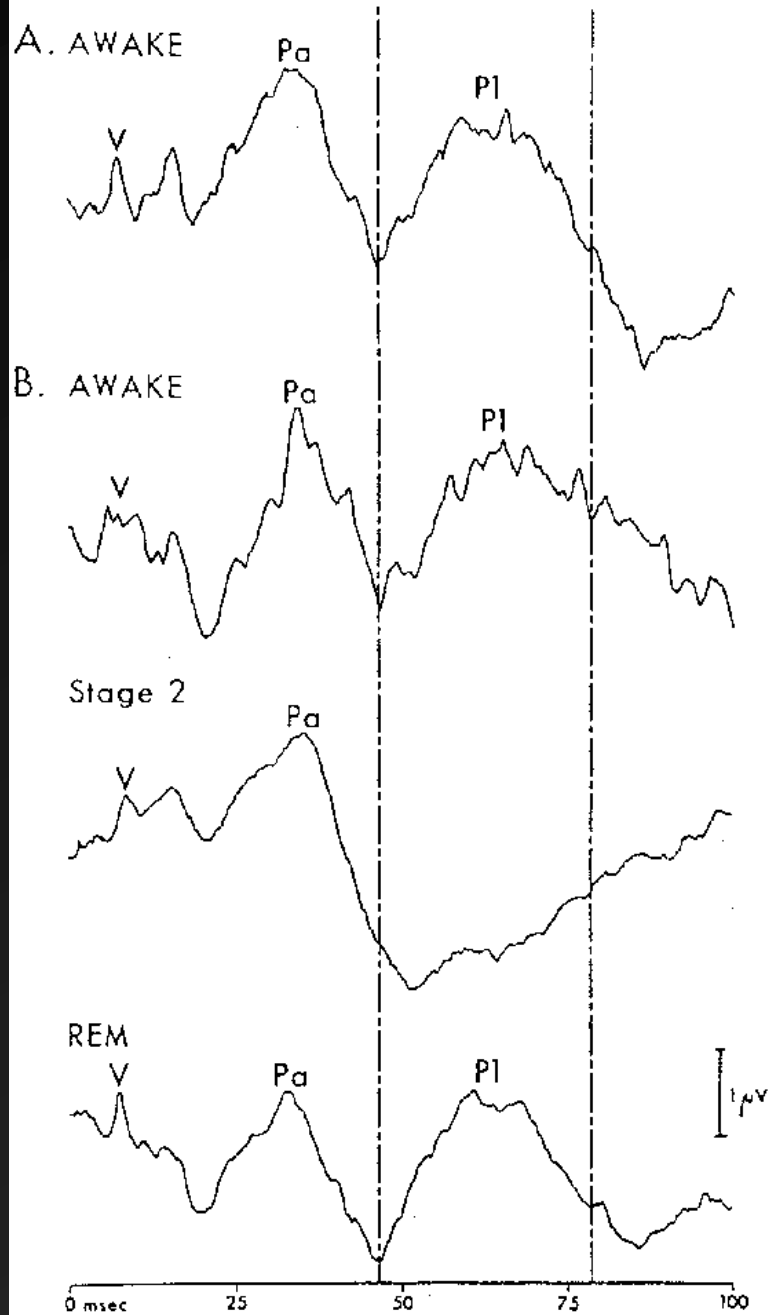

Figure 3.

Left: Observed potential distributions in the attend-left-minus-attend-right difference waves at the peak of the P1 attention effect (110–130 msec). **Right:** Corresponding model potential distributions seeded by the dorsal occipital PET foci, which provided an excellent fit to the P1 effect (residual variance 2%).

P1 REAPPEARANCE DURING REM

SUBJECT K.K.



P1 and Sleep

Note P1 disappears in Stage 2 sleep,
but reemerges in REM sleep

Construct Validity of P300 (P3, P3b)

- First observed by Sutton, Braren, Zubin, & John (1965): *Evoked-Potential Correlates of Stimulus Uncertainty*

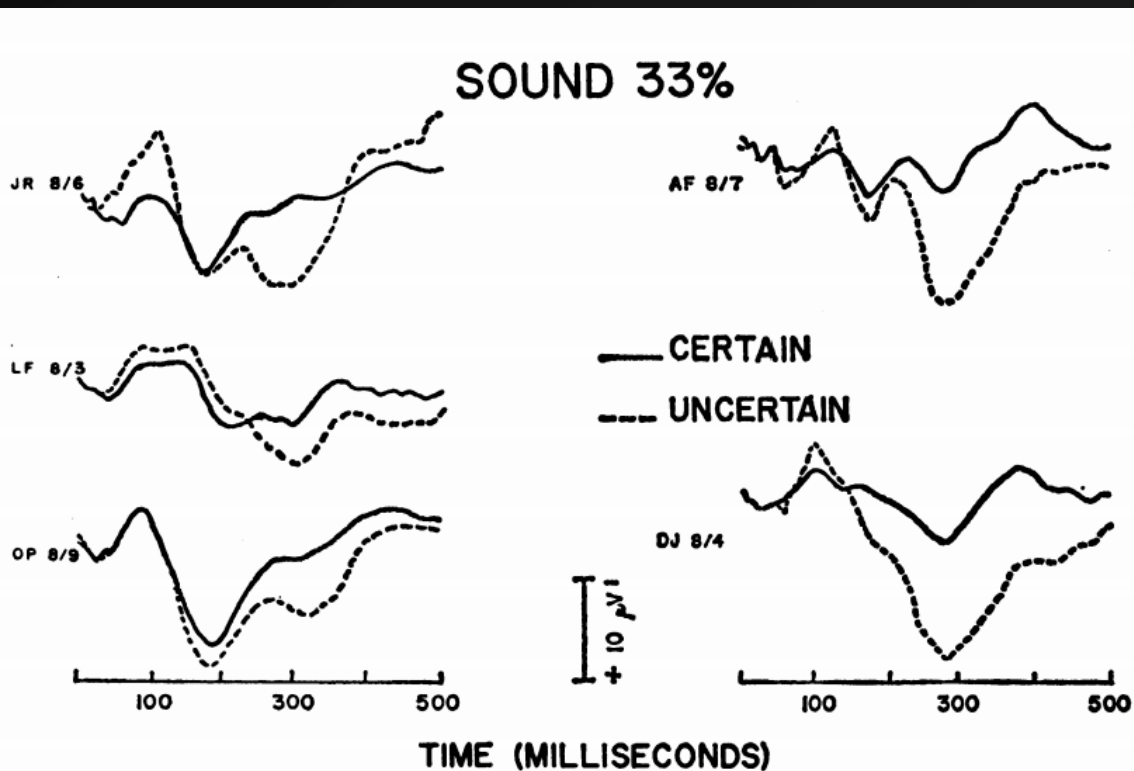

Fig. 1. Average waveforms for certain and uncertain ($P = .33$) sounds for five subjects.

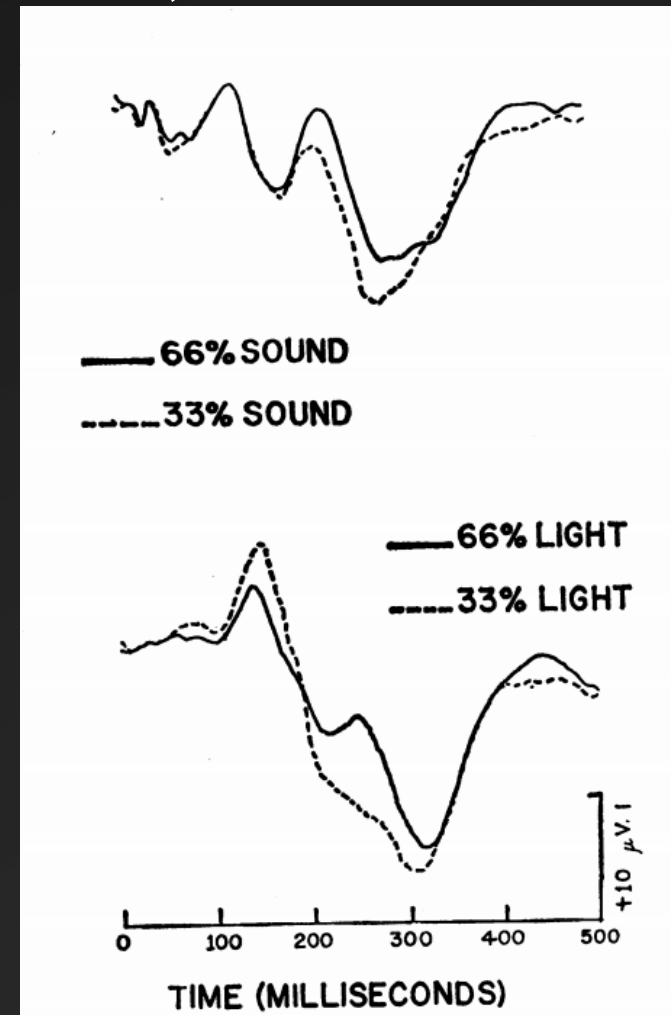

Fig. 2. Average waveforms for different probabilities of sound and light. The 33 percent sound and the 66 percent light had one cueing stimulus while the 66 percent sound and the 33 percent light had a different cueing stimulus.

Construct Validity of P300 (P3, P3b)

➤ First observed by Sutton, Braren, Zubin, & John (1965):

➤ P300 Amplitude; Johnson's model is

$$\text{P300 Amplitude} = f[T \times (1/P + M)]$$

where

➤ P = probability of occurrence,

➤ M = Stimulus meaning, &

➤ T = amount of information transmitted

Aspects of the Model

➤ Rarity

- The P300 is observed in variants of the "oddball paradigm"
- The rare stimulus almost invariantly elicits a P300: largest at parietal, then central, and then frontal sites
- Subjective probability

➤ Stimulus meaning

- Actually composed of three dimensions
 - task complexity
 - stimulus complexity
 - stimulus value
- Information Transmission (proportion 0 to 1; example)

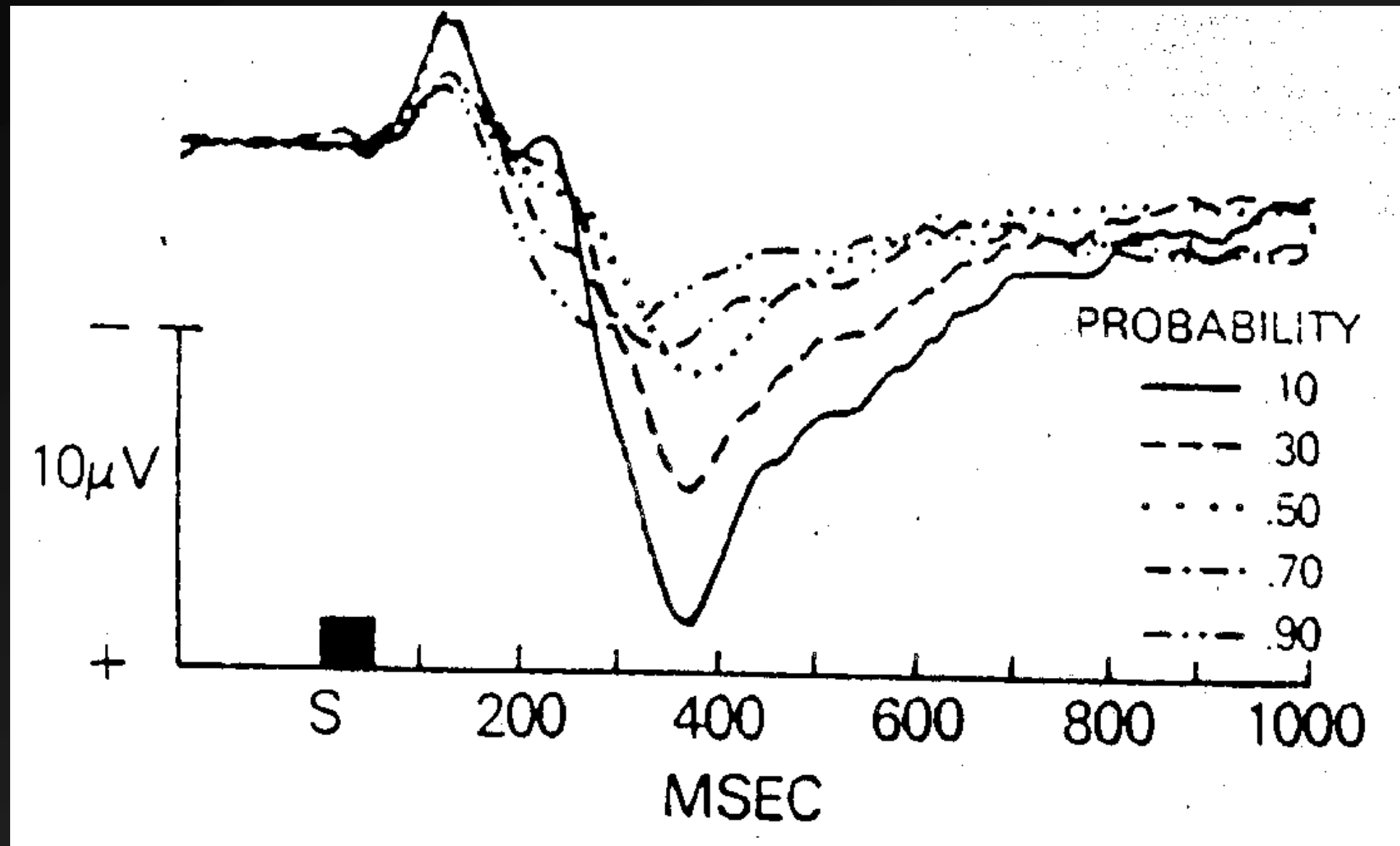

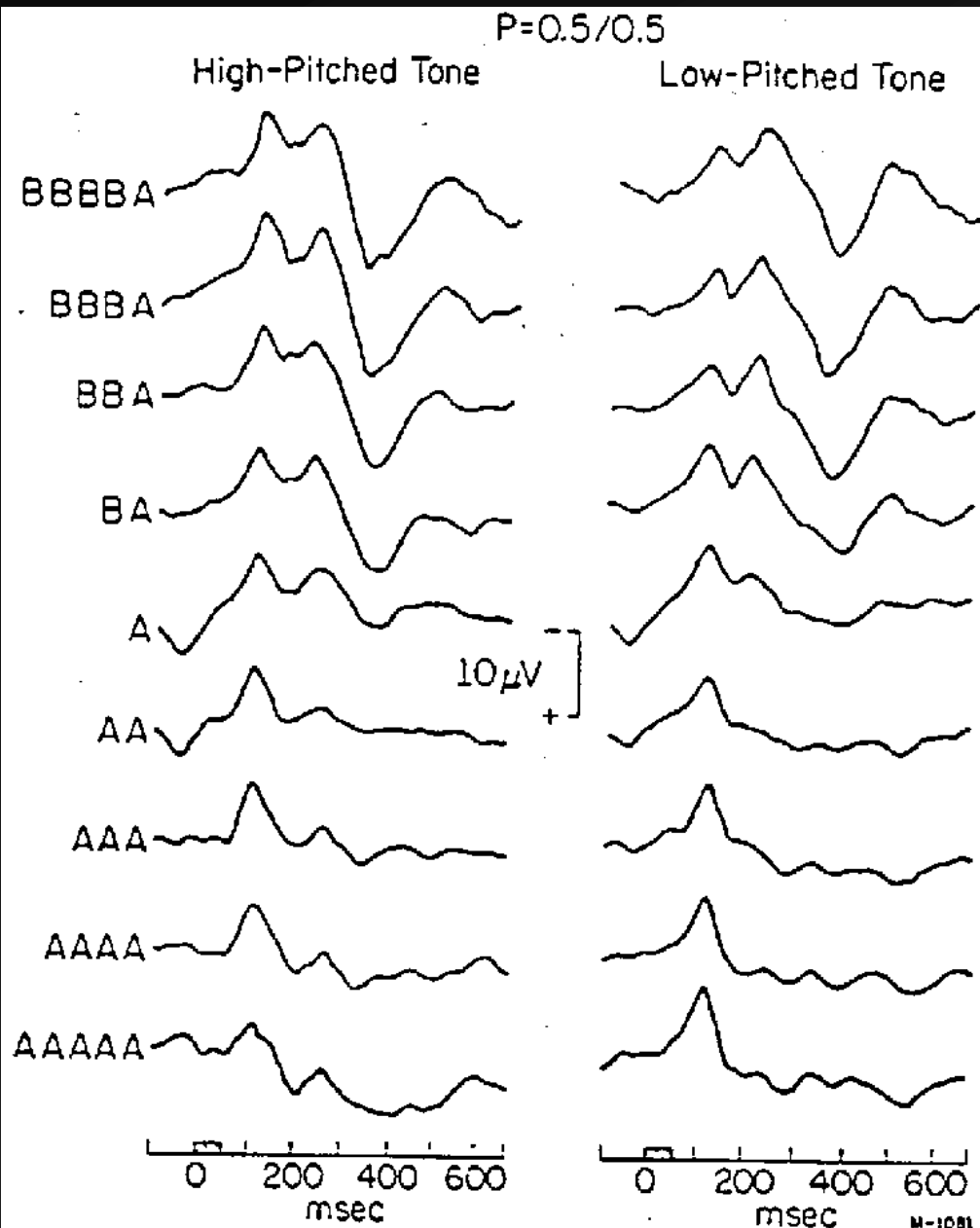

Figure 12-1. The ERPs in each column were elicited by the same physical tone; high-pitched tones were used for the left column and low-pitched tones for the right column. Both were presented in a Bernoulli series in which the probability of the two stimuli were equal. In the middle of each column (labeled "A") is the ERP elicited by all the presentations of the stimulus. The curve labeled "AA" was obtained by averaging together all the tones of one frequency that were preceded on the previous trial by tones of the same frequency. On the other hand, the curves labeled "BA" were elicited by stimuli preceded on the previous trial by the tones of different frequency. Similar sorting operations were applied to all other curves in this figure. It can be seen that the same physical tone elicited quite different ERPs, depending on the events that occurred on the preceding trials. Whenever a tone terminated a series of tones from the other category, a large P300 was elicited, and its magnitude was a function of the length of the stimulus series. (From "Effect of Stimulus Sequence on the Waveform of the Cortical Event-Related Potential," by K. C. Squires, C. D. Wickens, N. K. Squires, and E. Donchin. *Science*, 1976, 193, 1142-1146. Copyright 1976 by the AAAS.

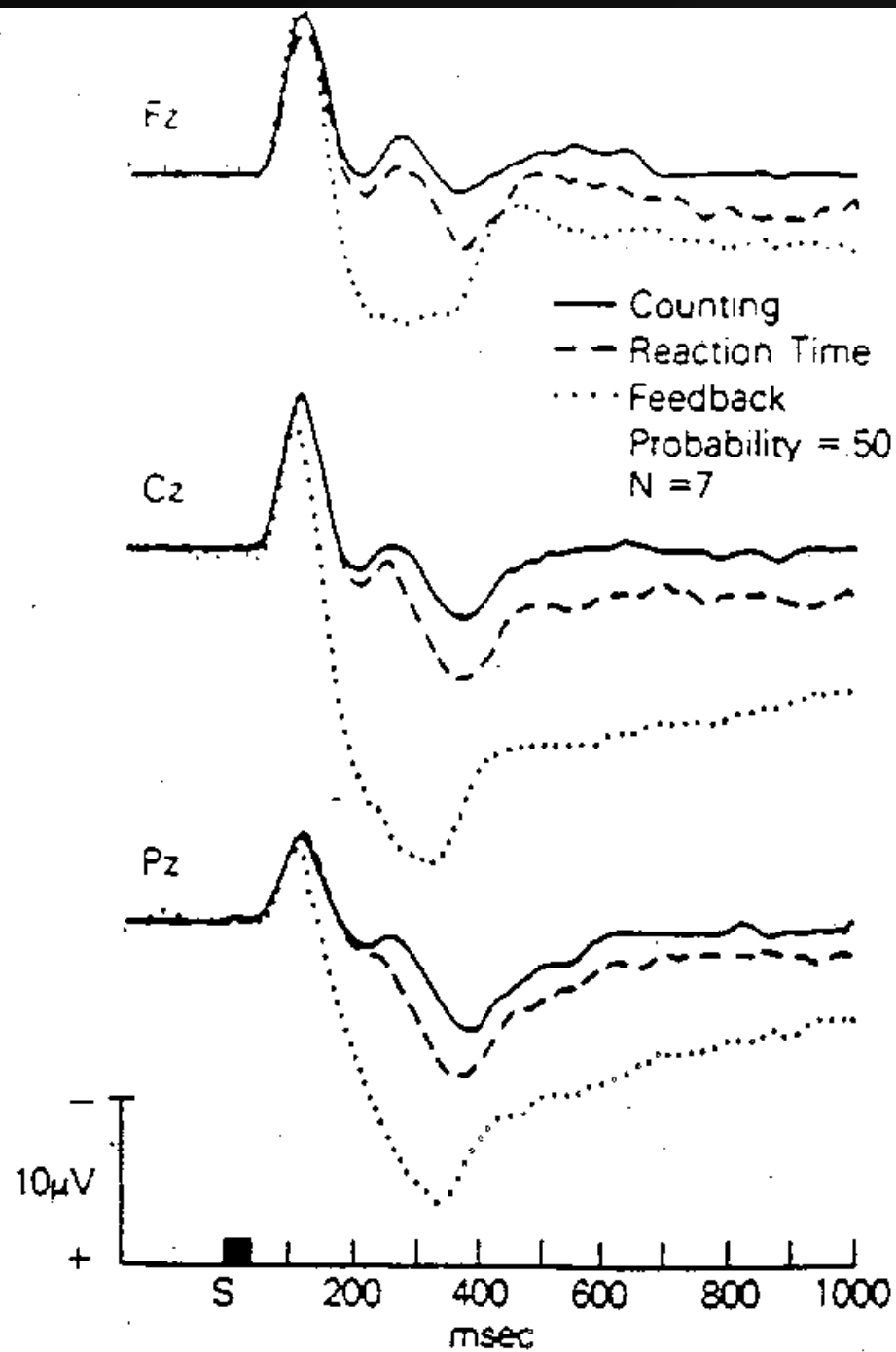

Figure 2. Grand-mean waveforms ($N=7$) from F_z , C_z , and P_z from three different tasks. The ERPs elicited in an oddball paradigm run under two different task conditions, Counting (solid line) and Reaction Time (dashed line), are superimposed on the ERP elicited when the same stimulus signified correct performance in a feedback paradigm (dotted line). The waveforms were all elicited by a 1000 Hz, 50dB SL tone ($p=.50$).

Information Transmission

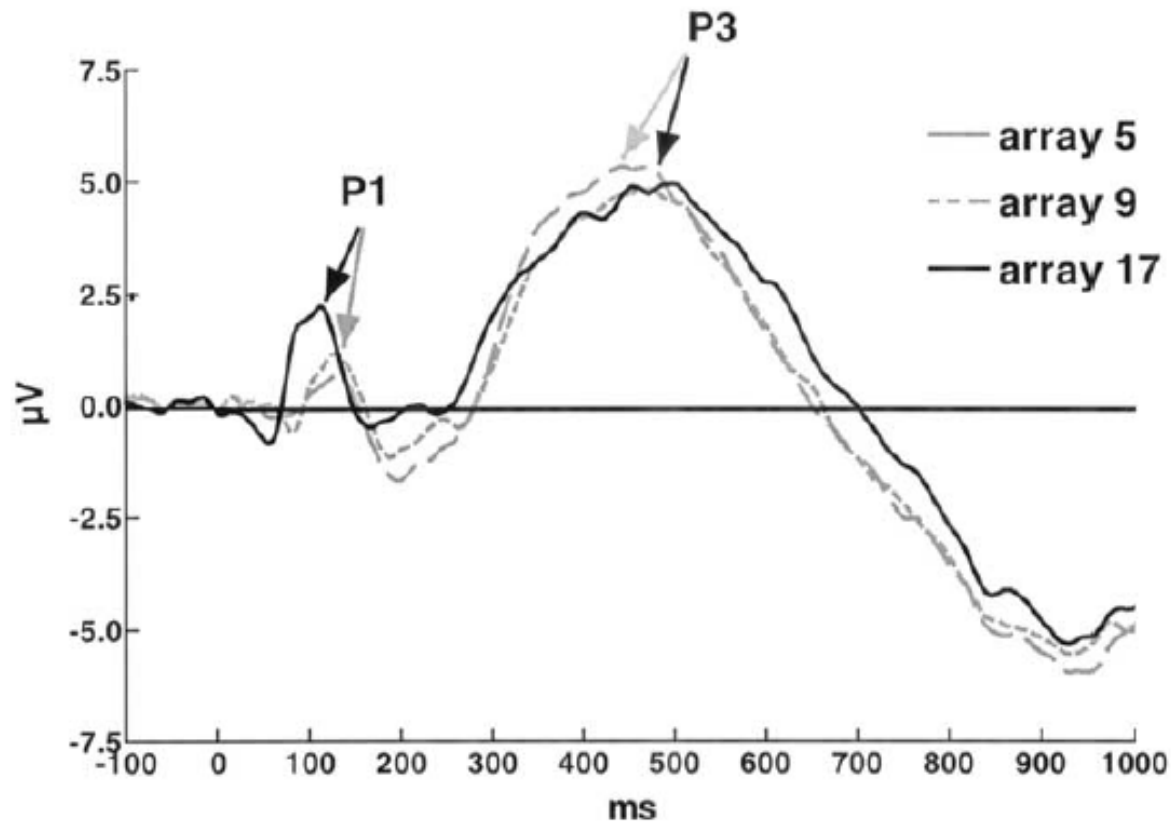

Fig. 2. Grand averaged visual ERPs at Pz electrode for the 3 array sizes, showing the shorter latencies, larger P1s for array size 17, but longer latency P3 (dark arrows) than for array sizes 5 and 9 (grey arrows). These are averaged across colour, orientation and conjunction conditions, as this ERP effect was seen regardless of whether it was a single feature or conjunction trial.

Taylor
Clinical Neurophys
2002

P3 Latency

- An index of processing time, independent of response requirements
 - RT measures confounds the two
 - McCarthy & Donchin (1981) experiment:
 - The words "RIGHT" or "LEFT" embedded in a matrix of letters of X's
 - Compatible condition: respond with hand indicated in matrix; Incompatible condition: respond with opposite hand (e.g., LEFT signals right hand response);
 - Results:
 - P300 latency delayed when discriminability more difficult
 - Response compatibility had no effect on P300 latency
 - **Note amplitude reduction as function of noise--information transmission)**

A

No noise

#####

#####

#R I G H T

#####

#####

##L E F T

#####

#####

a

b

Noise

NR I G H T

KW S M N T

BM J U K M

U Y R M U D

E Q È I K M

V T F M Z S

K E H E H G

I L E F T A

c

d

1°

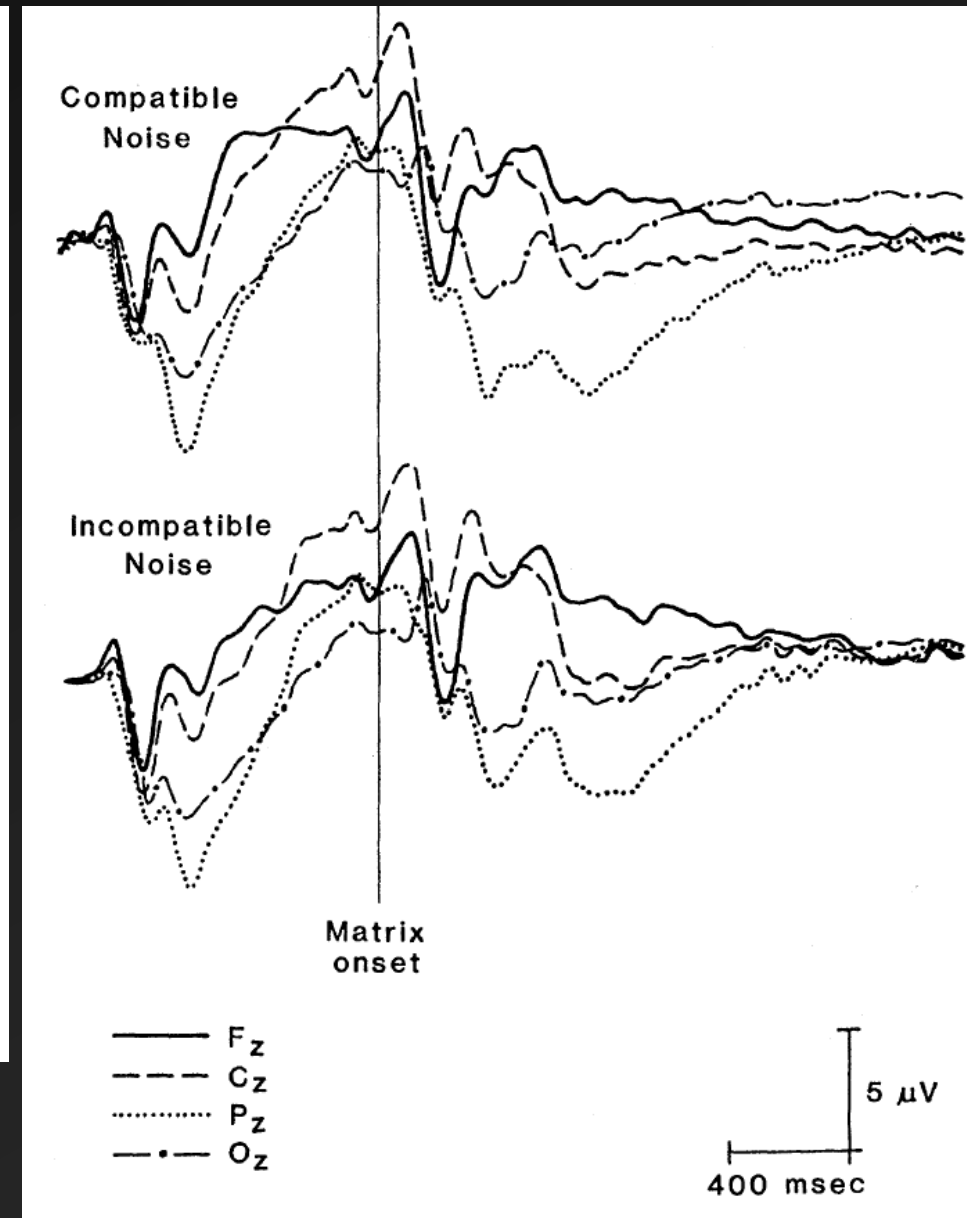
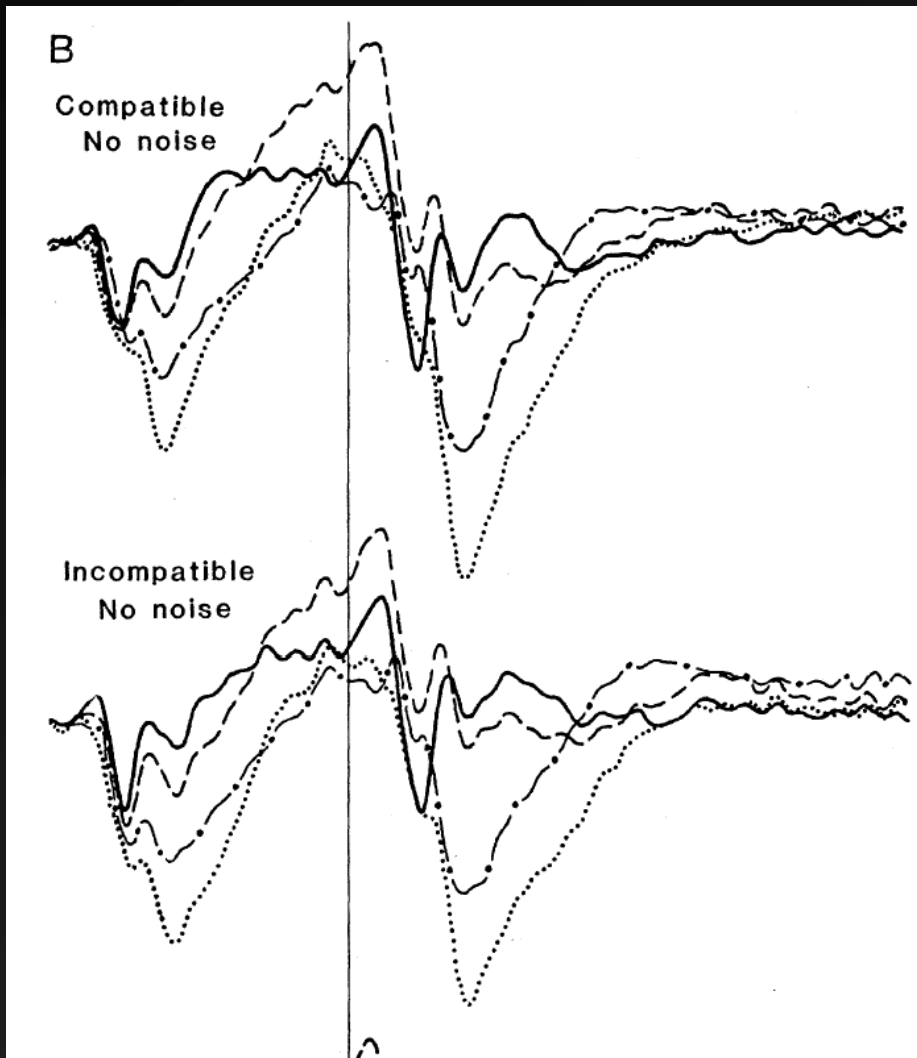

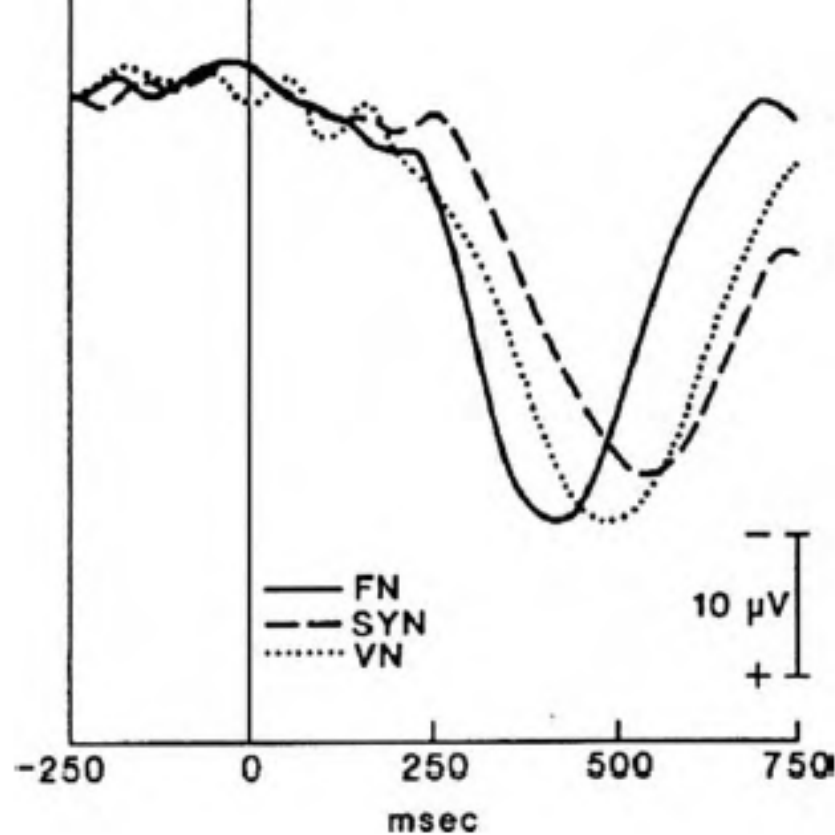

Not only difficulty in physical discrimination, but difficulty in cognitive categorization

Figure 4.10. ERP waveforms at Pz averaged across subjects for three different semantic categorization tasks. The solid line indicates ERPs obtained during a task in which the subjects had to distinguish between the word DAVID and the word NANCY (the FN condition). The dotted line indicates ERPs obtained during a task in which the subjects had to decide whether a word presented was a male or a female name (the VN condition). The dashed line indicates ERPs obtained during a task in which the subjects had to decide whether a word was or was not a synonym of the word PROD (SYN condition). These three tasks were considered to involve progressively more difficult discriminations. Note the latency of P300 peak is progressively longer as the discrimination is made more difficult. (Copyright 1977, AAAS. Adapted with permission of the author and publisher from Kutas, McCarthy, & Donchin, 1977.)

Construct Validity?

- What, then, does the P300 mean in very general terms?
 - A stimulus (or class of stimuli) is "important"; denotes information that is necessary or useful to the task
 - Stimulus is meaningful, important, noticeable
 - Evaluated within context of working memory? (cf. Donchin & Coles, 1988; Verleger 1988; Polich, 2007; Verleger, 2008)
- The P3a (Squires, Squires, and Hillyard, 1975): P3-like component with a frontal maximum and occurs to improbable stimuli in the "to-be-ignored" class of stimuli; a novelty response.