

Lecture 2

1 February, 2021

Announcements (02/01/21)

- 401B and 501B:
 - Laboratory Meeting Wed Feb 3, 3⁰⁰-5⁰⁰ pm
(Zoom link on D2L)
- Electricity Test in 2 weeks (Feb 15)

Questions and Feedback

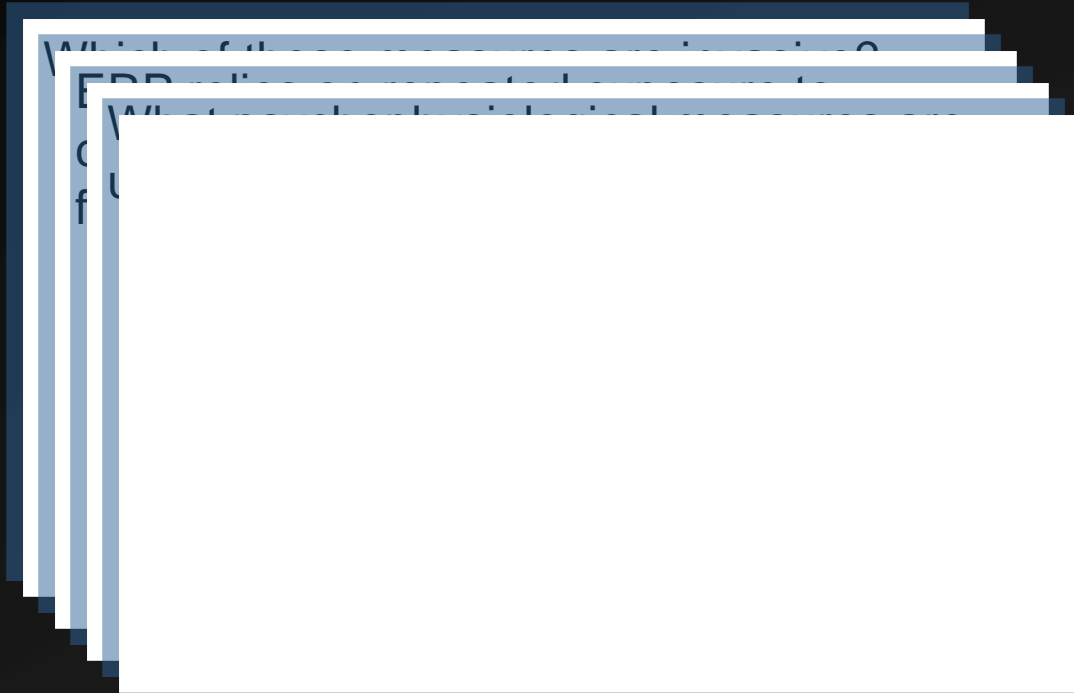

Foundations:

Basic Electricity

Basic Neurophysiology

Basic Neuroanatomy

But First...

Finishing up from last lecture

A few selected studies to highlight the utility of a psychophysiological approach

- Bauer (1984): Prosopagnosia
- Öhman & Soares (1993): Phobias
- Spiegel (1985): Hypnosis
- Deception Detection studies
- Investigation of Persistent Vegetative State
- Brain-Computer Interfaces for assisted communication

Farwell & Donchin (1991) Psychophysiology

- Conventional Polygraphy unacceptably inaccurate
- Rather than rely on autonomic arousal, could rely on a cognitive response of recognition
- Mock Crime Scenario, multiple choice (variant of Guilty Knowledge Test)
 - Clothing of contact (“Green Hat”)
 - Name (“Tim Howe”)
 - Operation codename (“Op Pig”)
 - Location (“Shark Street”)
 - ...

Ongoing EEG

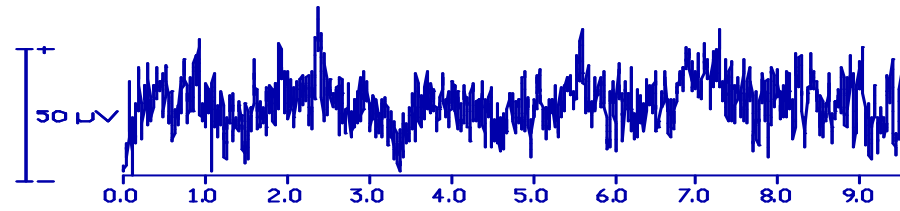

Stimuli



Visual Event-related Potential

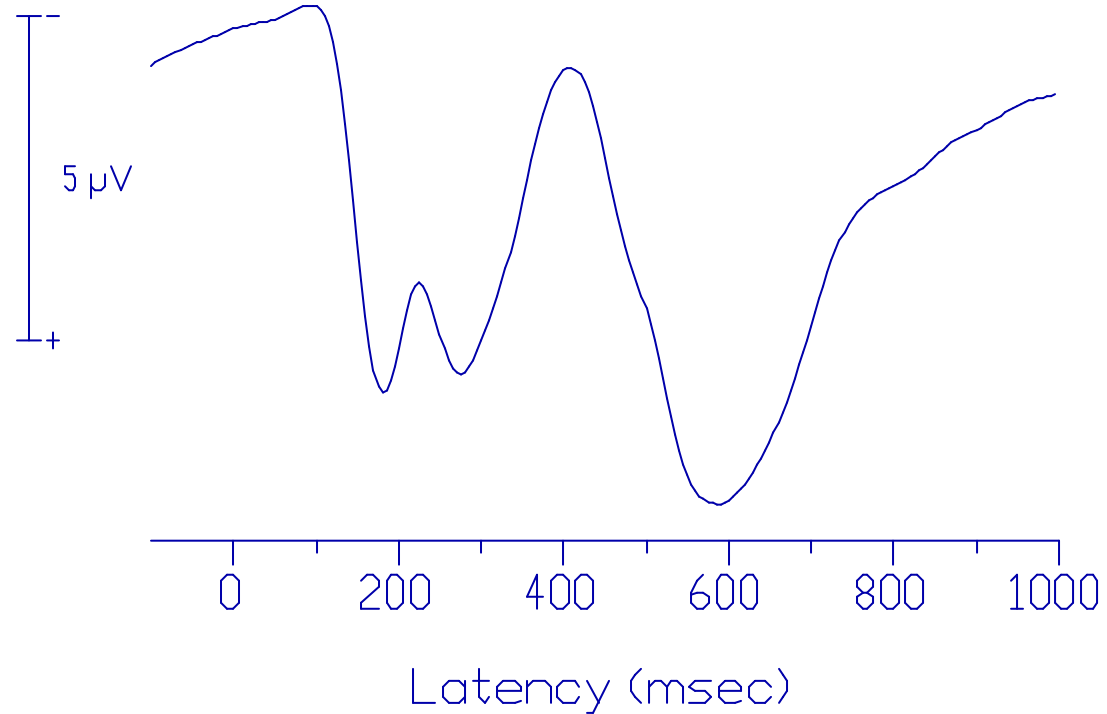

Rationale

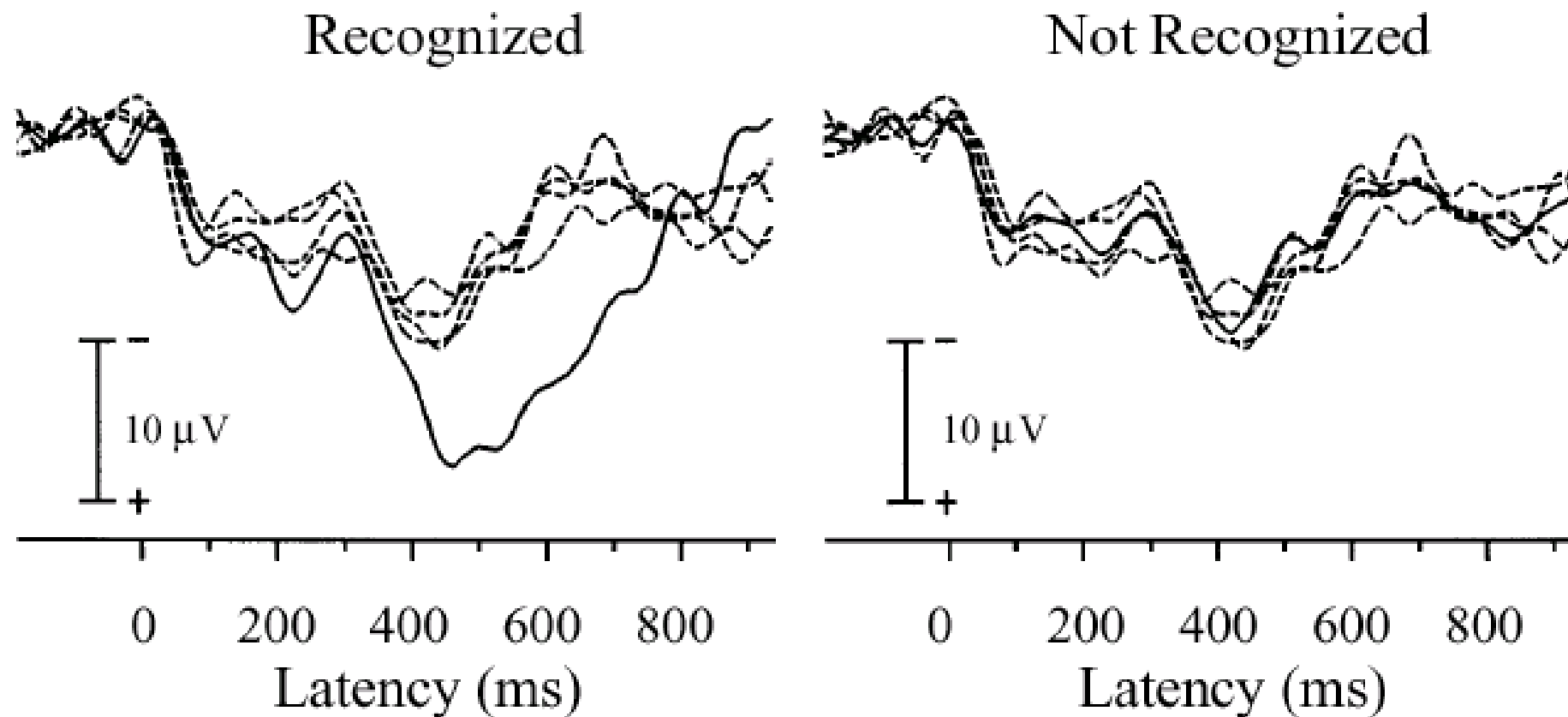

Bootstrap Index for "Guilty" and "Innocent" Conditions

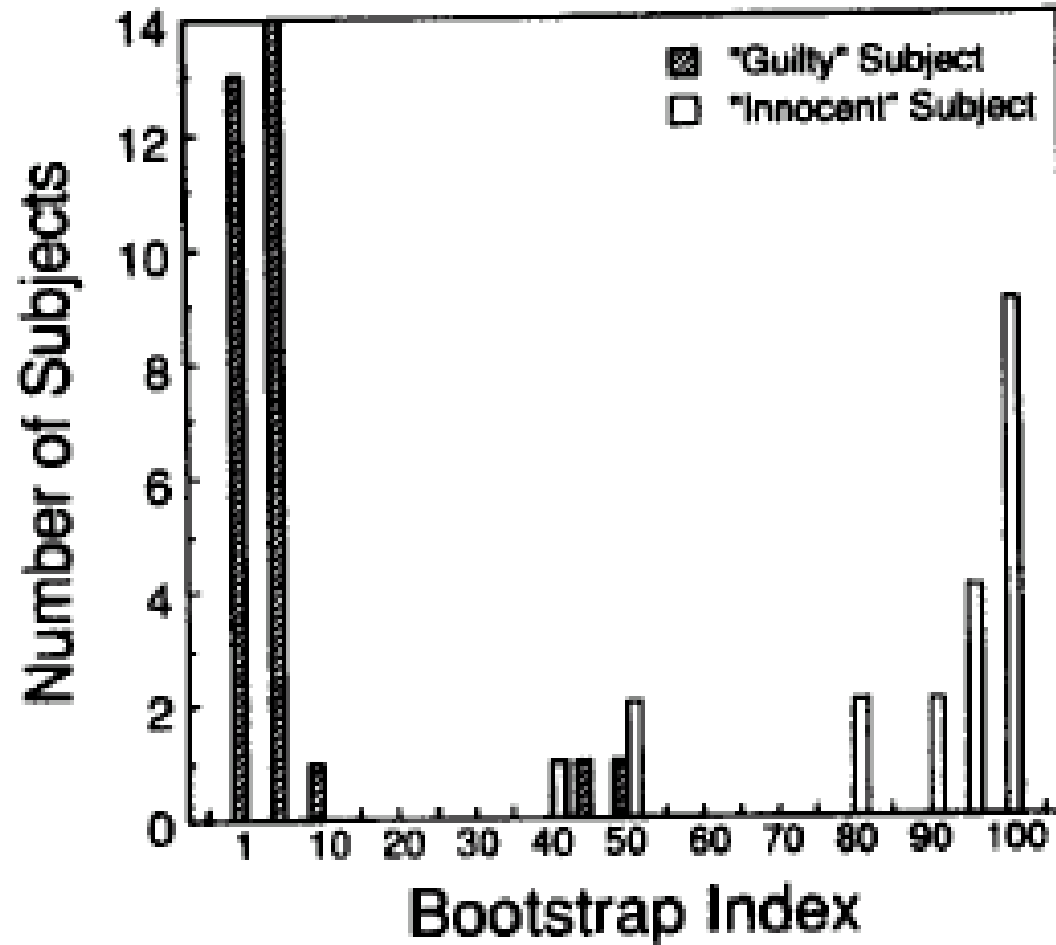

Figure 2. The distribution of the bootstrap statistic for all 40 tests conducted in Experiment 1. Dark bars indicate the number of subjects who were "guilty" and were assigned a given bootstrap value. Light bars show the same data for the "innocent" subjects.

Table 2

2A: ACCURACY OF DETERMINATIONS

Decision	Subject State		Total
	Guilty	Innocent	
Guilty	18	0	18
Innocent	0	17	17
Indeterminate	2	3	5
Total	20	20	40

Conceal

Lie

Lie + Money

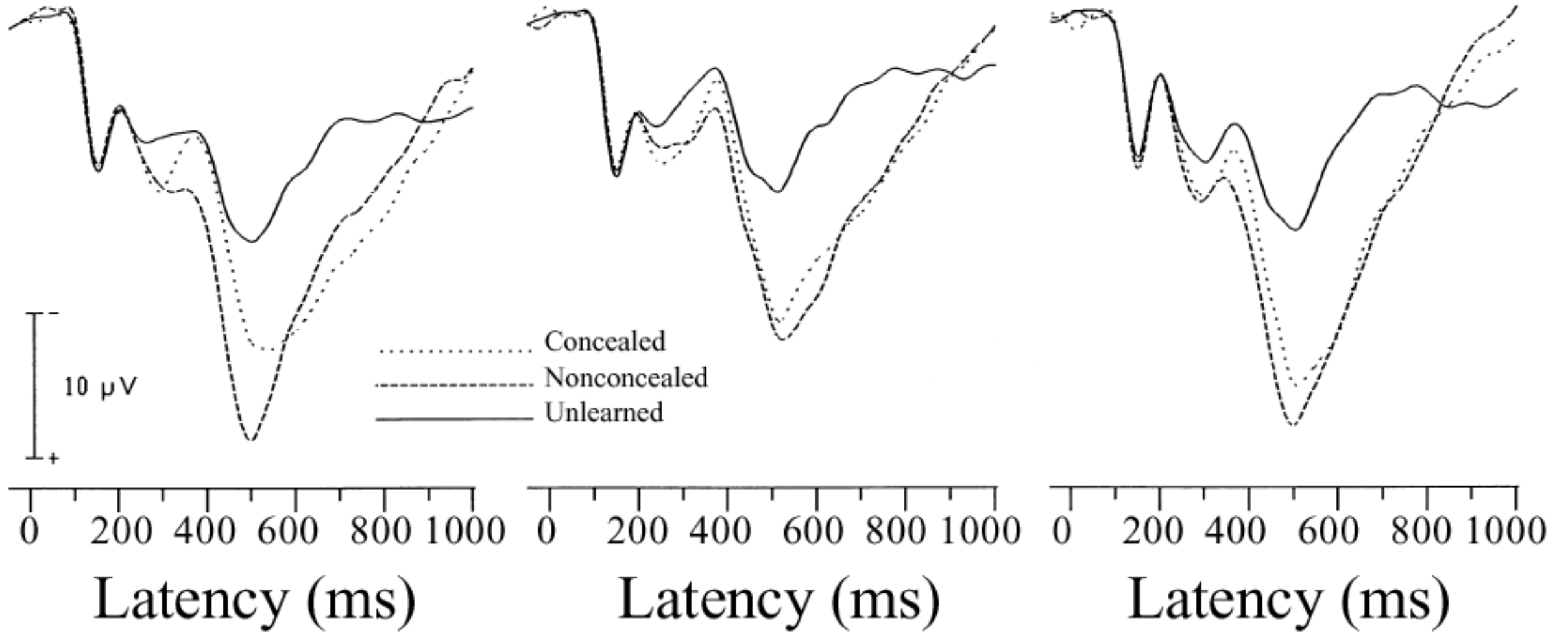

A few selected studies to highlight the utility of a psychophysiological approach

- Bauer (1984): Prosopagnosia
- Öhman & Soares (1993): Phobias
- Spiegel (1985): Hypnosis
- Deception Detection studies
- Investigation of Persistent Vegetative State
- Brain-Computer Interfaces for assisted communication

Persistent Vegetative State

- PVS patients typically are not non-responsive
 - But responses to varied stimuli lack:
 - voluntary components
 - cognitive aspects
 - evidence of awareness of self
 - evidence of awareness of surroundings.
 - No meaningful communication
- MCS (Minimally Conscious State) by contrast:
 - Minimal, if even highly inconsistent, signs of conscious behavior can be observed

Persistent Vegetative State

- Diagnostic errors in PVS up to 40% (Andrews et al., 1996)
- Might psychophysiological assessment help?
 - How best to validate such new measures against some gold standard when diagnostic errors are so common?
 - Create continuous measure and link to physiology (Wijnen, van Boxtel, Eilander, & de Gelder (2007) *Clinical Neurophysiology*)
 - Range from complete non-response to normal consciousness

Levels of Consciousness (LoCs)

Global level	Score	Description of the levels
Coma		<i>Eyes are closed all the time. No sleep–wake cycles present.</i>
	1	All major body functions such as breathing, temperature control, or blood pressure can be disturbed. Generally, no reactions are noticed after stimulation. Sometimes reflexes (stretching or flexing) can be observed as a reaction when strong pain stimuli have been applied. No other reactions present.
Vegetative State (VS)		<i>Patient has some sleep–wake cycles, but no proper day–night rhythm. Most of the body functions are normal. No further ventilation is required for respiration.</i>
	2	Very little response (hyporesponsive) Generally no response after stimulation. Sometimes delayed presentation of reflexes is observed.
	3	Reflexive state Often stimuli result in massive stretching or startle reactions, without proper habituation. Sometimes these reactions evaluate into massive flexing responses. Roving eye movements can be seen, without tracking. Sometimes grimacing occurs after stimulation.
	4	High active level and/or reactions in stimulated body parts Generally spontaneous undirected movements. Retracting a limb following stimulation. Orienting towards a stimulus, without fixating. Following moving persons or objects, without fixating.
Minimally Conscious State (MCS)		<i>Patient remains awake most of the day.</i>
	5	Transitional state Following and fixating of persons and objects. Generally more directed reactions to stimuli. Behaviour is automatic, i.e. opening of the mouth when food is presented, or reaching towards persons or objects. Sometimes emotional reactions are seen such as crying or smiling towards family or to specific (known) stimuli.
	6	Inconsistent reactions Sometimes, but not always, obeying simple commands. Totally dependent. Patient has profound cognitive limitations; neuropsychological testing is impossible. Level of alertness is fluctuating, but in general low.
	7	Consistent reactions Patient obeys simple commands. The level of alertness is high and stable. Many cognitive disturbances remain. Patient is totally dependent.
Consciousness	8	Patient is alert and reacts to his/her environment spontaneously. Functional understandable mutual communication is possible, sometimes with technical support. As yet, cognitive and behavioural disturbances can be present.

Mismatch Negativity

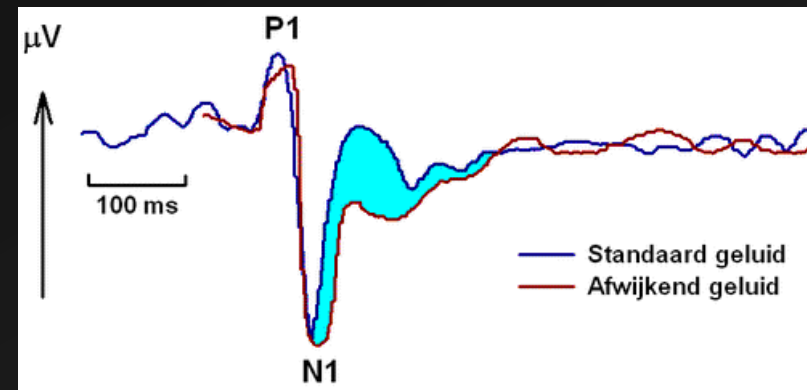

- Discovered by Näätänen, Gaillard, & Mäntysalo, 1978
- Rare deviant (“Afwijkend geluid”) elicits sustained negative voltage at scalp, maximal at fronto-central sites
 - Regardless of whether the stimuli are attended
 - Can vary in pitch, loudness, duration



Longitudinal Study

- Create continuous measure and link to physiology (Wijnen, van Boxtel, Eilander, & de Gelder (2007) *Clinical Neurophysiology*)
- Ten severely brain-injured patients (age 8-25)
- Longitudinal assessment starting 9 days after admission (and then every 2 weeks)

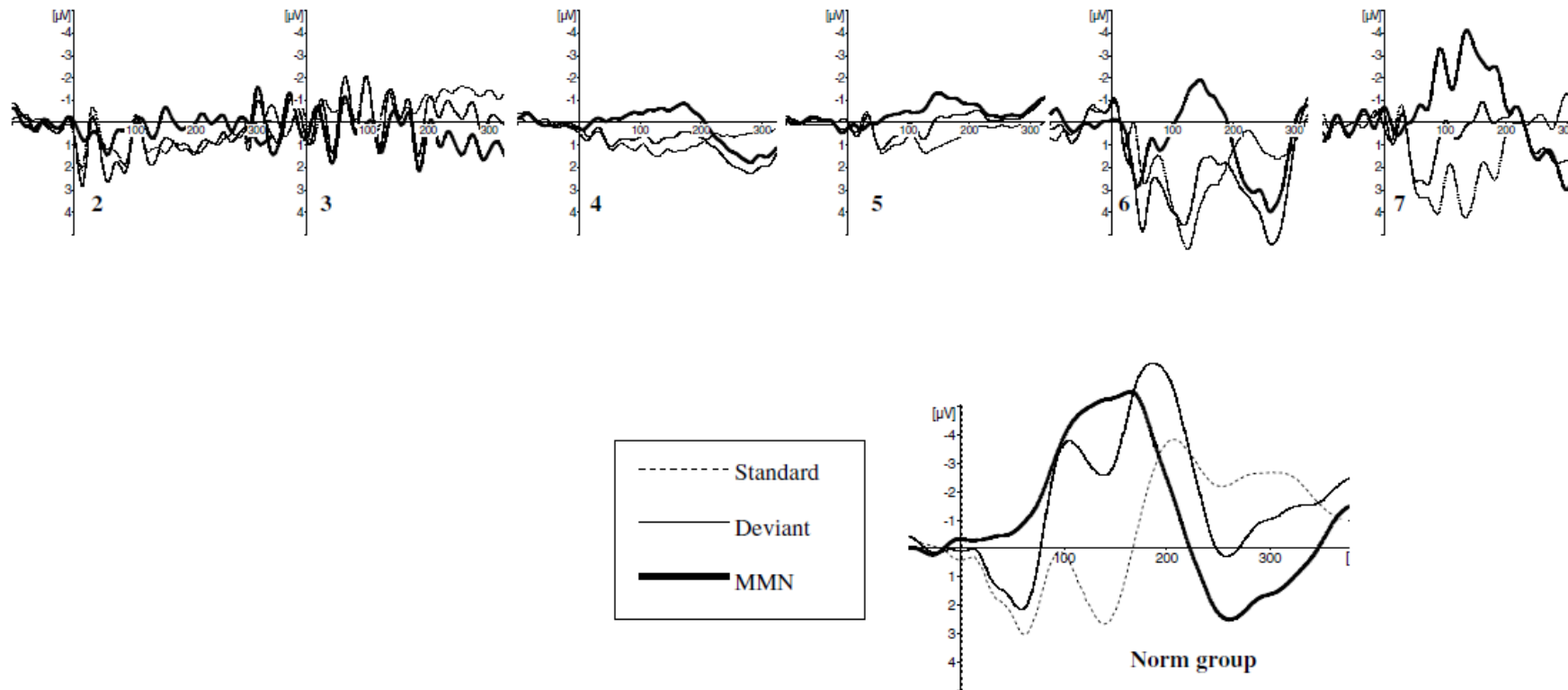

Fig. 2. Grand averages of MMN (Fz-linked Mastoids, 0.15–30 Hz, 48 dB/octave) for each Level of Consciousness according to the levels in Table 2 versus the norm group. Potentials related to the standard stimuli, potentials related to the deviant stimuli, and the MMN (difference between the deviant and standard).

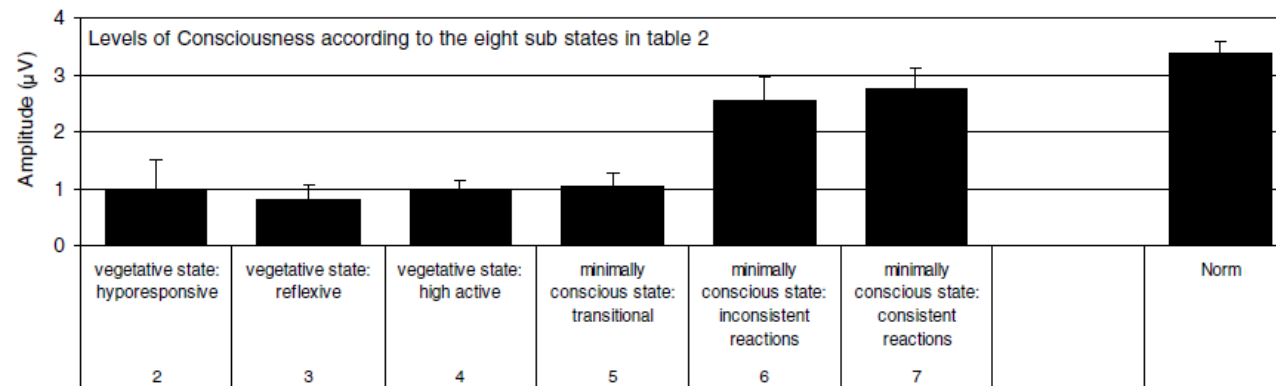
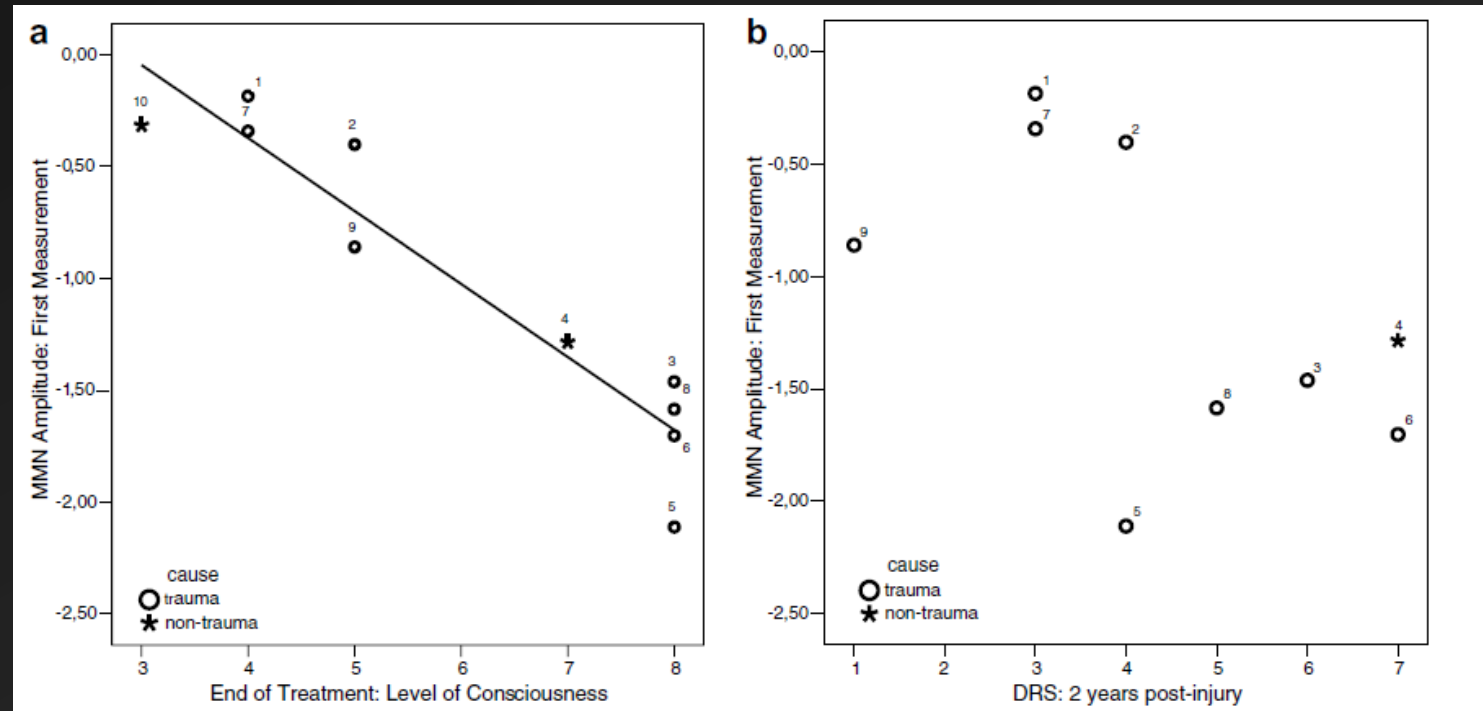

Fig. 1. Longitudinal measurements: mean MMN-amplitude (Fz) and standard error for each Level of Consciousness according to the levels in Table 2 versus the norm group. For number of measurements see Table 3.

Longitudinal Study

- Predictive value?
 - MMN during first assessment strongly predicted level of consciousness at discharge ($\beta = -.94$, $p < .00001$)
 - Also predicted functional outcome two years later



Another approach

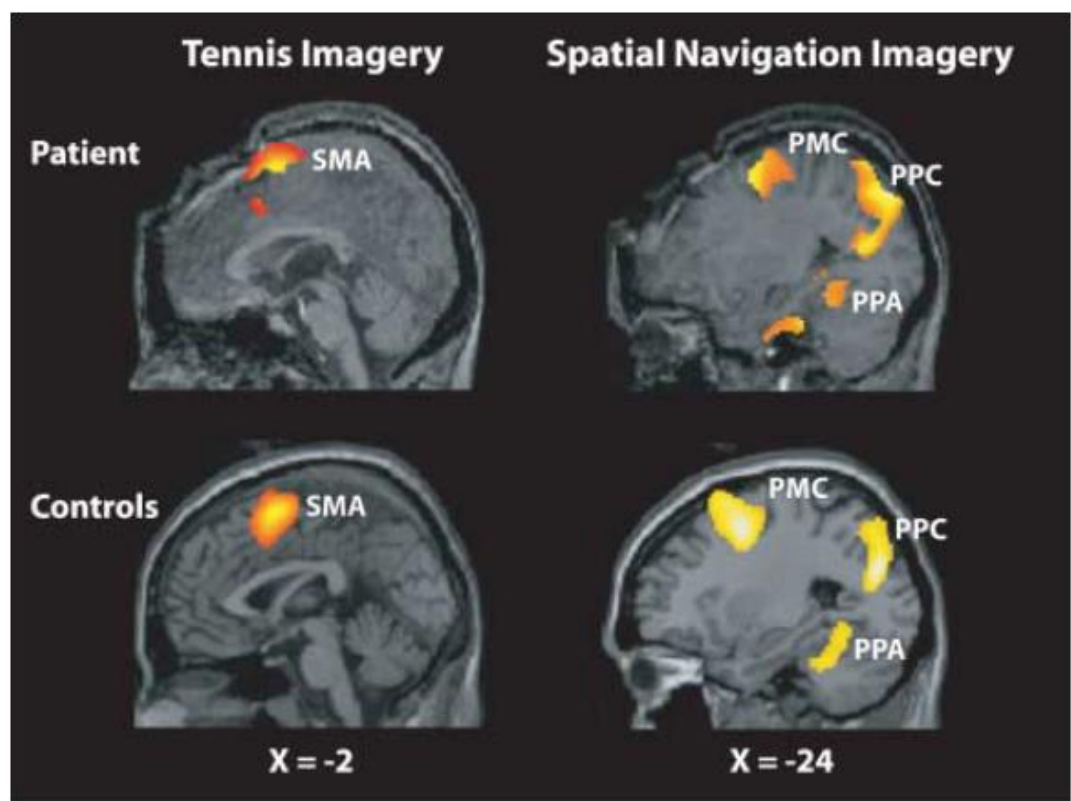

Fig. 1. We observed supplementary motor area (SMA) activity during tennis imagery in the patient and a group of 12 healthy volunteers (controls). We detected parahippocampal gyrus (PPA), posterior parietal-lobe (PPC), and lateral premotor cortex (PMC) activity while the patient and the same group of volunteers imagined moving around a house. All results are thresholded at $P < 0.05$ corrected for multiple comparisons. X values refer to distance in mm from the midline in stereotaxic space (SOM text).

“These results confirm that, despite fulfilling the clinical criteria for a diagnosis of vegetative state, this patient retained the ability to understand spoken commands and to respond to them through her brain activity, rather than through speech or movement.”

“... suggests a method by which some noncommunicative patients, including those diagnosed as vegetative, minimally conscious, or locked in, may be able to use their residual cognitive capabilities to communicate their thoughts to those around them by modulating their own neural activity.”

See also:

Naci L, Owen AM. Making Every Word Count for Nonresponsive Patients. [JAMA Neurol. 2013 Aug 12.](https://doi.org/10.1001/jamaneurol.2013.3686) doi: 10.1001/jamaneurol.2013.3686.

A few selected studies to highlight the utility of a psychophysiological approach

- Bauer (1984): Prosopagnosia
- Öhman & Soares (1993): Phobias
- Spiegel (1985): Hypnosis
- Deception Detection studies
- Investigation of Persistent Vegetative State
- Brain-Computer Interfaces for assisted communication

Syndromes where interaction with environment difficult or impossible

- Amyotrophic lateral sclerosis (ALS)
- Vegetative States

Farwell & Donchin (1988) *Electroencephalography and clinical Neurophysiology*

- Attempted to develop an applied ERP system for communication without motor system involvement
- For “locked in” patients

CRT Display Used in the Mental Prosthesis

MESSAGE

BRAIN

Choose one letter or command

A	G	M	S	Y	*
B	H	N	T	Z	*
C	I	O	U	*	TALK
D	J	P	V	FLN	SPAC
E	K	Q	W	*	BKSP
F	L	R	X	SPL	QUIT

Fig. 1. CRT display used in the mental prosthesis. The rows and columns of the matrix were flashed alternately. The letters selected by the subject ('B-R-A-I-N') were displayed at the top of the screen in the pilot study.

c P300 –Brain-Computer-Interface (BCI)

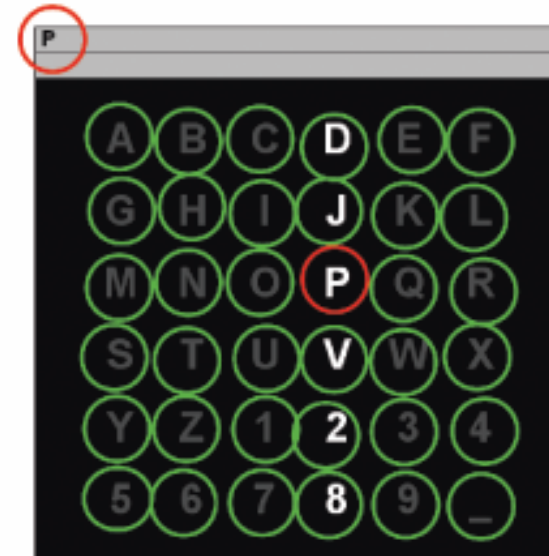
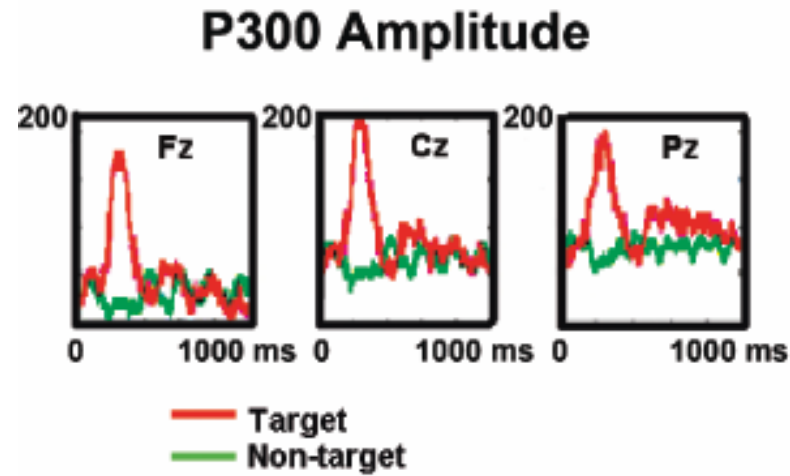

P300-BCI. Rows and columns of letter strings are lighted in rapid succession. Whenever the desired letter (P) is among the lighted string, a P300 appears in the EEG (after Sellers & Donchin 2006; Piccione et al.2006).

Can't we speed things up?



<http://www.youtube.com/watch?v=2KtMCX7FfZ0>

<https://www.youtube.com/watch?v=zqYJQGk5l4M>

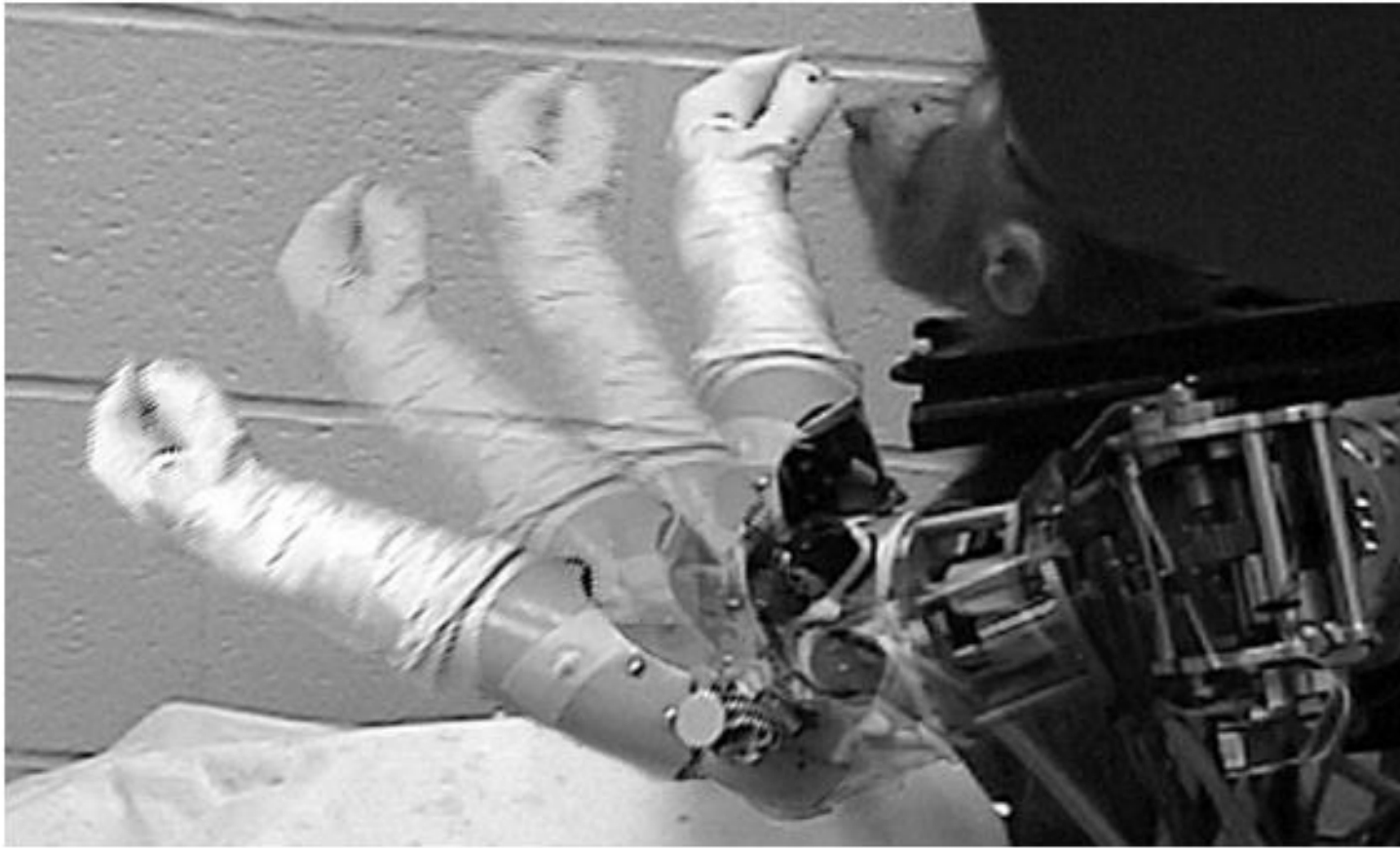

Fig. 4. A monkey is feeding himself with the aids of a robotic arm by producing the same pattern of neural activity in the motor cortex as would be required to move his own limb. The trajectory of the robot arm is depicted sequentially. In expectancy of the piece of an apple, the monkey protrudes his tongue. From the monkey only the head is visible. (We thank Dr. Andrew Schwartz, from the School of Medicine, University of Pittsburgh, Pittsburgh, USA, for this picture and for the permission of reproduction.)

Operant methods (Birbaumer et al.)

IEEE TRANSACTIONS ON BIOMEDICAL ENGINEERING, VOL. 51, NO. 6, JUNE 2004

1011

Brain-Computer Communication and Slow Cortical Potentials

Thilo Hinterberger*, Stefan Schmidt, Nicola Neumann, Jürgen Mellinger, Benjamin Blankertz, Gabriel Curio,
and Niels Birbaumer

Senso-motor Rhythm Training

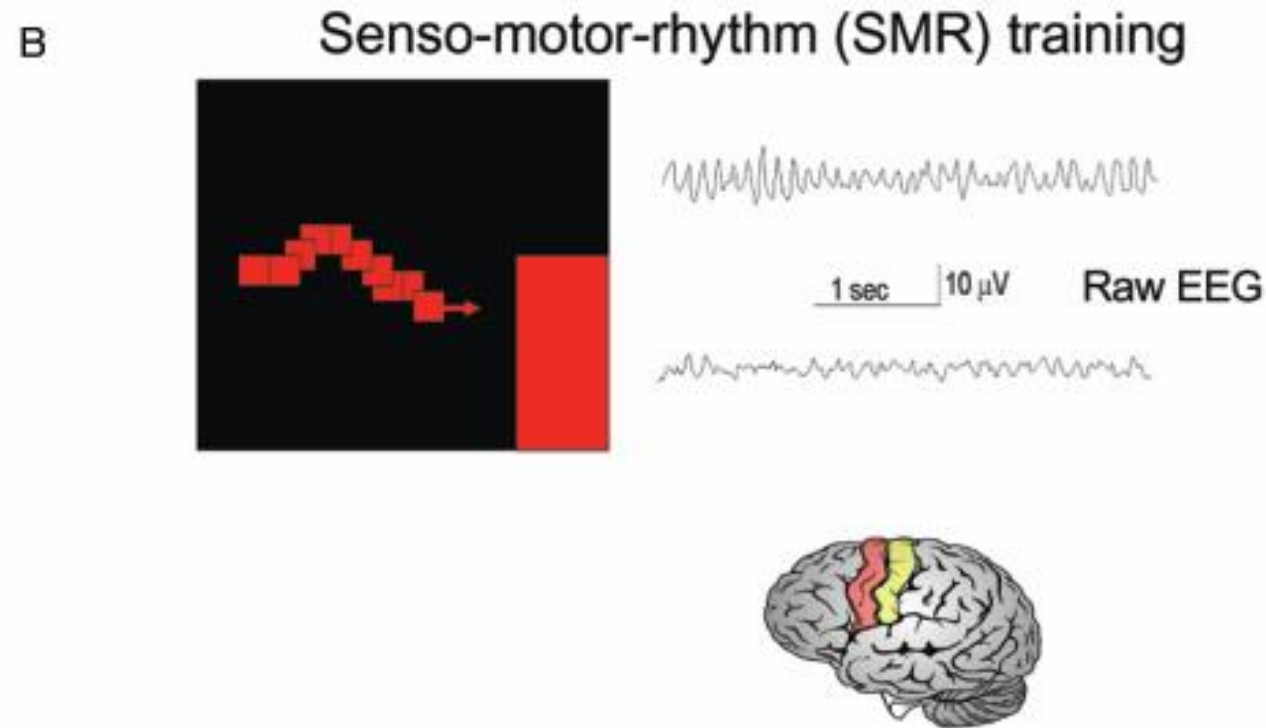

Top right: Senso-motor-rhythm (SMR) oscillations from sensorimotor cortex during inhibition of movement and imagery or execution of movement (EEG trace below). On the left part of the picture is the feedback display with the target goal on the right side of the screen indicating the required SMR increase (target at bottom) or SMR decrease (target at top). The cursor reflecting the actual SMR is depicted in red moving from the right side of the screen toward the target goal.

Senso-motor Rhythm Training

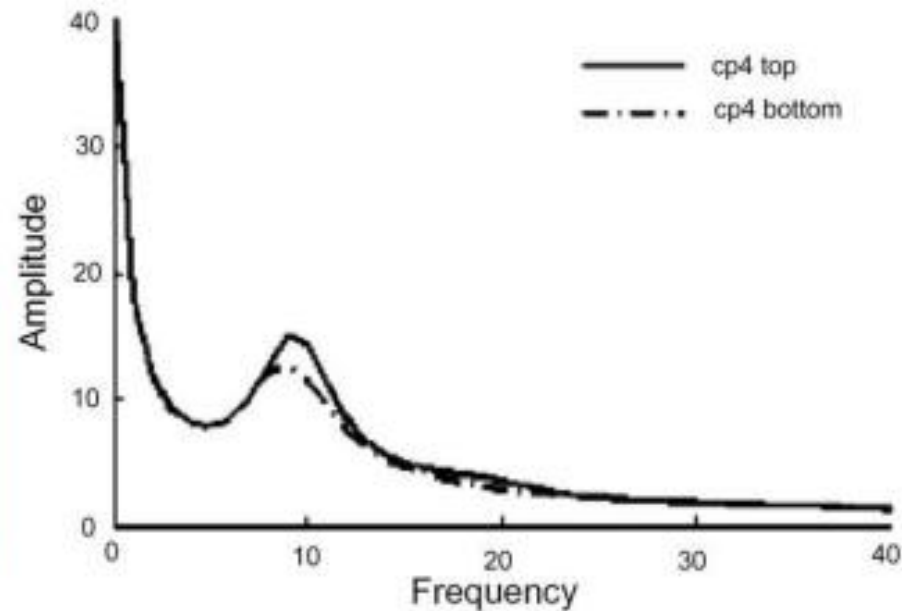
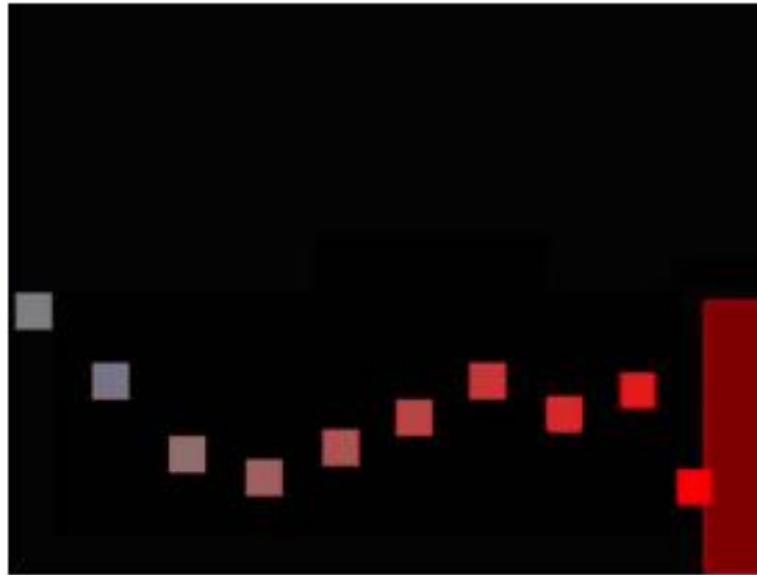

- Patients' task is to move the cursor into the target.
- Cursor movement is indicated by the squares (only one square is visible).
- The cursor moves steadily from left to right, vertical deflections correspond to the SMR amplitude.
- EEG frequency power:
 - Bold line: frequency power spectrum when the cursor had to be moved toward the top target
 - Dashed line: cursor had to be moved toward the bottom target.

Slow Cortical Potentials (SCP)

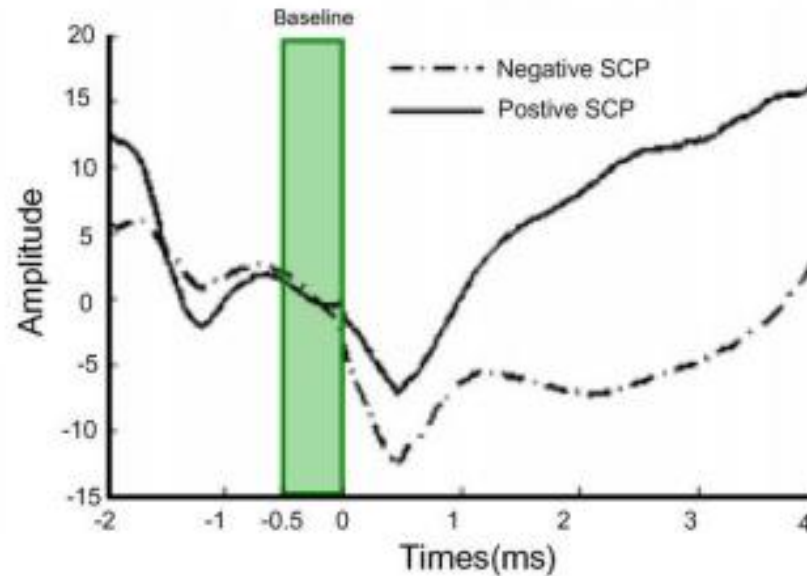
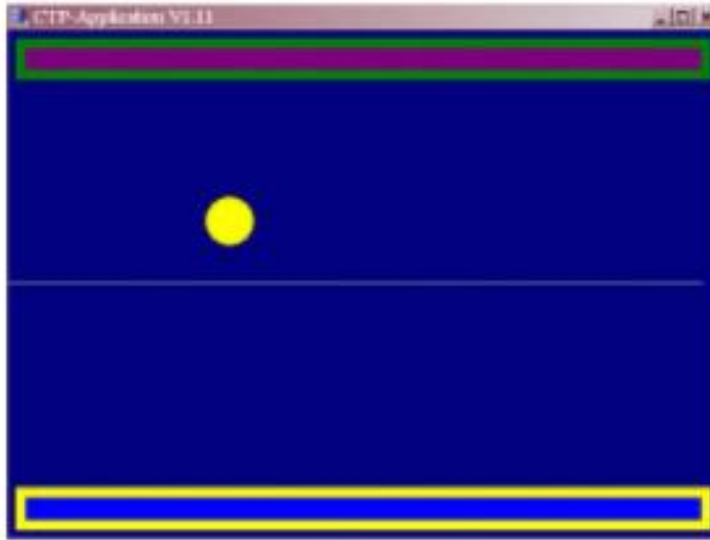

- Targets are presented at the top or bottom of the screen.
- Patients' task is to move the cursor (yellow dot) toward the target
- Cursor moves steadily from left to right and its vertical deflection corresponds to the SCP amplitude.
- A negative SCP amplitude (dashed line) moves the cursor toward the top, positive SCP amplitude (bold line) toward the bottom target.
- Before each trial, a baseline is recorded indicated by the green bar.
- At time point -2 s the task is presented, at -500 ms the baseline is recorded and at zero cursor movement starts.

A



BCI using slow cortical potentials (SCP depicted at the top). Patient selects one letter from the letter string on screen (right below) with positive SCPs, the spelled letters appear on top of the screen

Many Methods

- Many EEG DVs
- Many features to extract
- Many classification algorithms
- Meta-analysis of main methods

(Lotte, Bourgrain, Cichocki, Congedo, Rakotomamonjy, Yger (2018) *J Neural Engineering*)

Table 2. Summary of adaptive unsupervised classification methods explored.

EEG pattern	Features	Classifier	References
Motor imagery	Band power	Adaptive LDA with GMM	[24, 83, 129]
Motor imagery	Band power	Adaptive LDA with FCM	[130]
Motor execution	AR parameters	Adaptive Gaussian classifier	[149]
Motor imagery	Band power	Adaptive LDA	[132, 219]
Motor imagery	Band power	Adaptive Gaussian classifier	[131]
Motor imagery	Band power	Semi-supervised CSP+LDA	[137]
Motor imagery	Adaptive band power	Adaptive LDA	[63, 64, 220, 221]
Motor imagery	Adaptive CSP patches	Adaptive LDA	[196]
Covert attention	Band power	Incremental logistic regression	[133]
MRP	Band power	Incremental SVM	[9]
c-VEP	CCA	Adaptive one-class SVM	[206]
P300	Time points	SWLDA	[239]
P300	Time points	Semi-supervised SVM	[81, 122, 151]
P300	Time points	Co-training LDA	[178]
P300	Time points	Unsupervised linear classifier	[104, 105]
ErrP	Time points	Unsupervised linear classifier	[78]

Many Methods

- Many EEG DVs
- Many features to extract
- Many classification algorithms
- Meta-analysis of main methods

(Lotte, Bourgrain, Cichocki, Congedo, Rakotomamonjy, Yger (2018) *J Neural Engineering*)

- Commercial implementation:

<https://www.youtube.com/watch?v=XPWMpU1VuKU>

Foundations:

Basic Electricity

Basic Neurophysiology

Basic Neuroanatomy

Part I: Basic Electricity

- Prelude
- Atomic Stuff
- Voltage, Resistance, Current, Power, Energy
- DC Series Circuits
- DC Parallel Circuits
- AC Circuits in brief

Prelude: Scale of Measurement

- Deci = 10^{-1}
- Centi = 10^{-2}
- Milli = 10^{-3}
- Micro = 10^{-6}
- Nano = 10^{-9}
- Pico = 10^{-12}
- Fento = 10^{-15}

- Kilo = 10^3
- Mega = 10^6
- Giga = 10^9
- Tera = 10^{12}

Bits, Bytes, Mega, Giga, Tera (explained)

1 bit = a 1 or 0 (b)

4 bits = 1 nybble (?)

8 bits = 1 byte (B)

1024 bytes = 1 Kilobyte (KB)

1024 Kilobytes = 1 Megabyte (MB)

1024 Megabytes = 1 Gigabyte (GB)

1024 Gigabytes = 1 Terabyte (TB)

What's a Trillion \$ (Tera \$)

<http://www.pagetutor.com/trillion/index.html>

3.1 teradollars

The U.S. federal budget deficit for fiscal year 2020 was \$3.1 trillion. FY 2020 covers October 1, 2019, through September 30, 2020. The deficit occurs because the U.S. government spending of \$6.6 trillion is higher than its revenue of \$3.4 trillion.

6.6 teradollars

3.4 teradollars

So far in FY 2021, the U.S. federal budget monthly deficits have totaled \$284 billion, \$145 billion, and \$144 billion for Oct, Nov, and Dec, respectively.

284 gigadollars

145 gigadollars

144 gigadollars

Prelude: 3 Great Forces

- **Nuclear** Strong, very short (subatomic) distances ...
- **Electrostatic** Holds all kinds of stuff together in the everyday world
- **Gravitational** Weakest, but impressive over very large distances
and with large masses

Electrostatic Forces

- Due to charged subatomic particles
 - Proton
 - Electron
 - but not Neutron
- The Law:
 - Unlike Charges Attract
 - Like Charges Repel

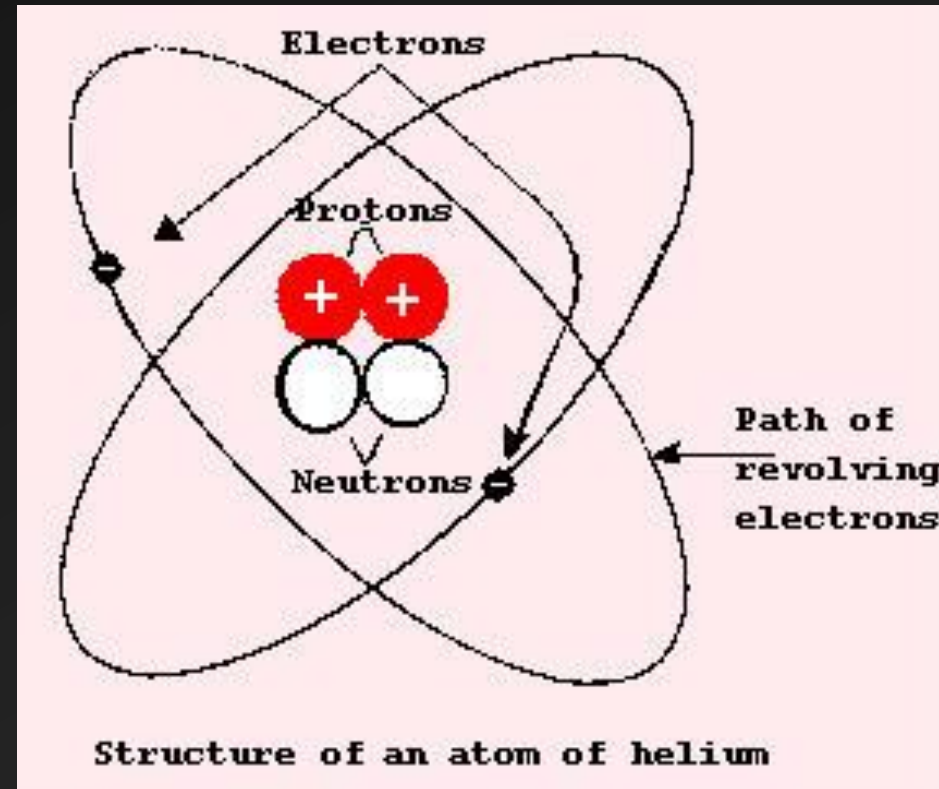

Free Electrons

- Some electrons can be easily displaced

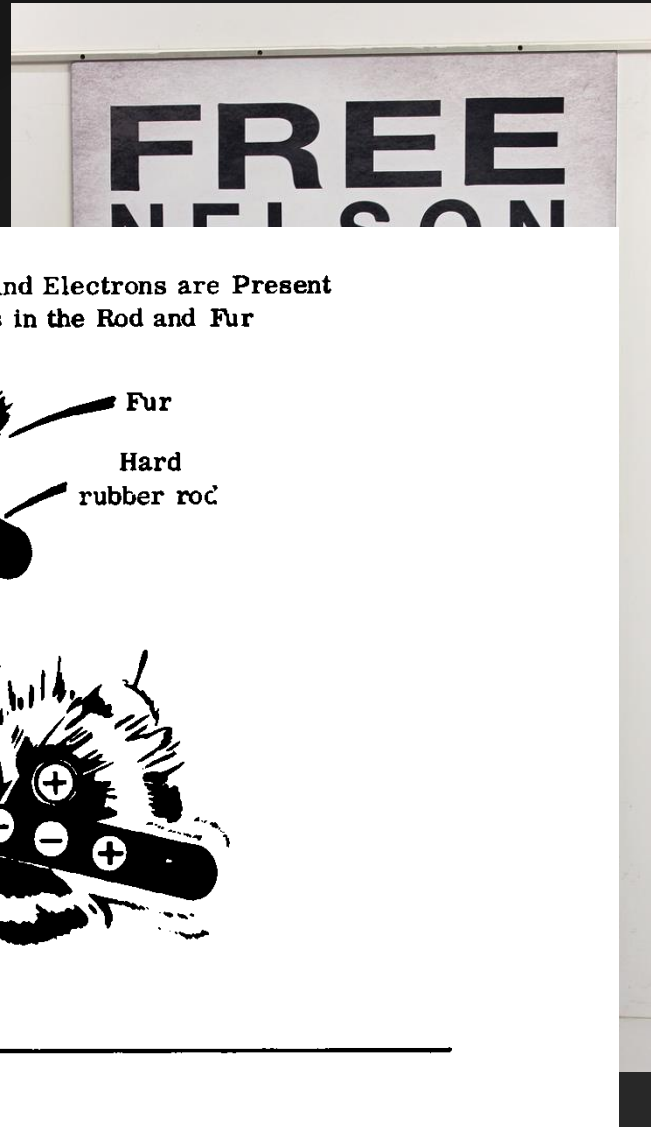

Static Electricity

- Friction with Poor Conductors
- Electrons displaced from one substance to the other (e.g Hair to comb, carpet to body)
- Leads to voltage potential (i.e., difference)

Basic Electricity by Analogy

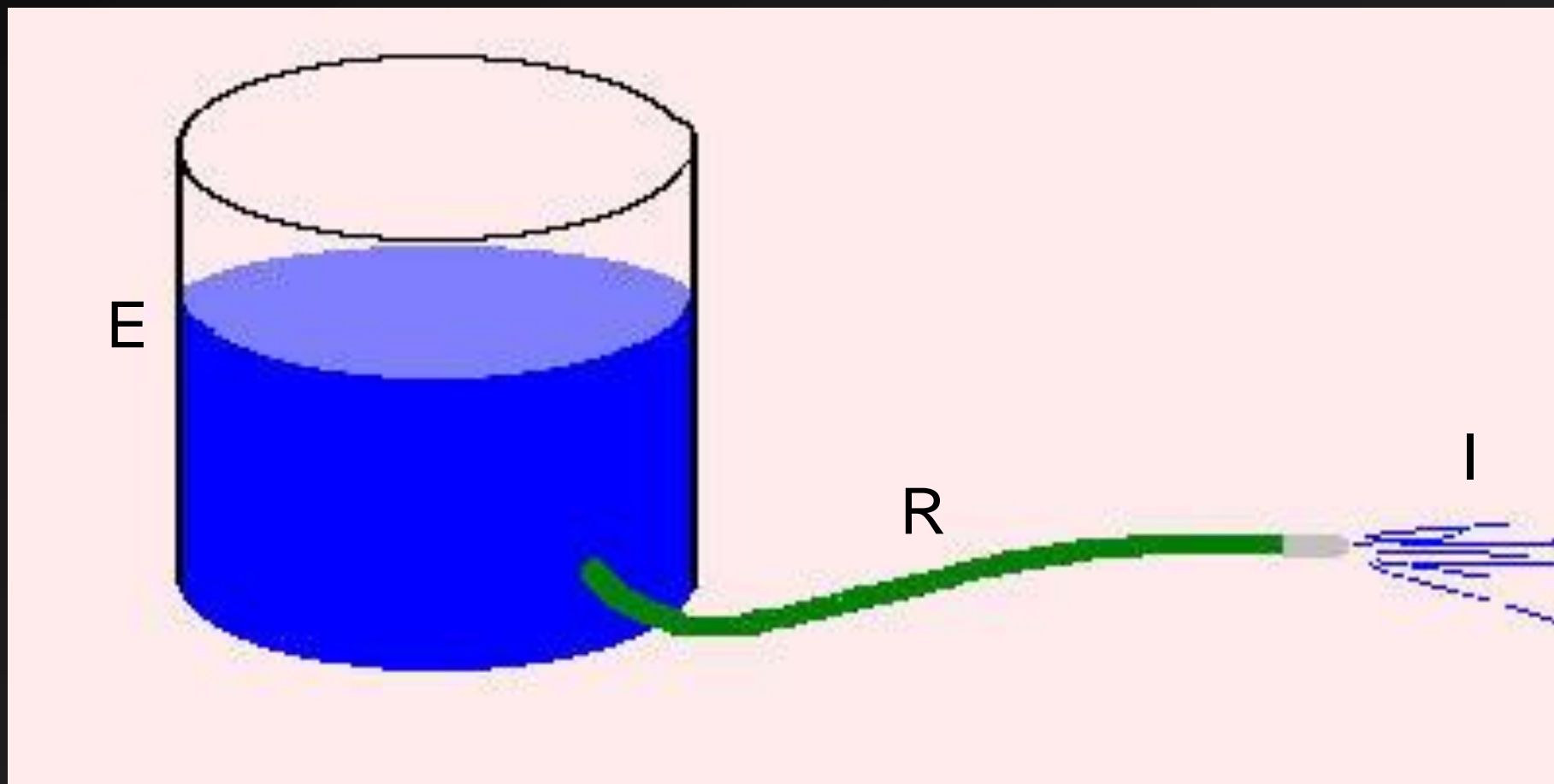

← Direction of Electron Movement

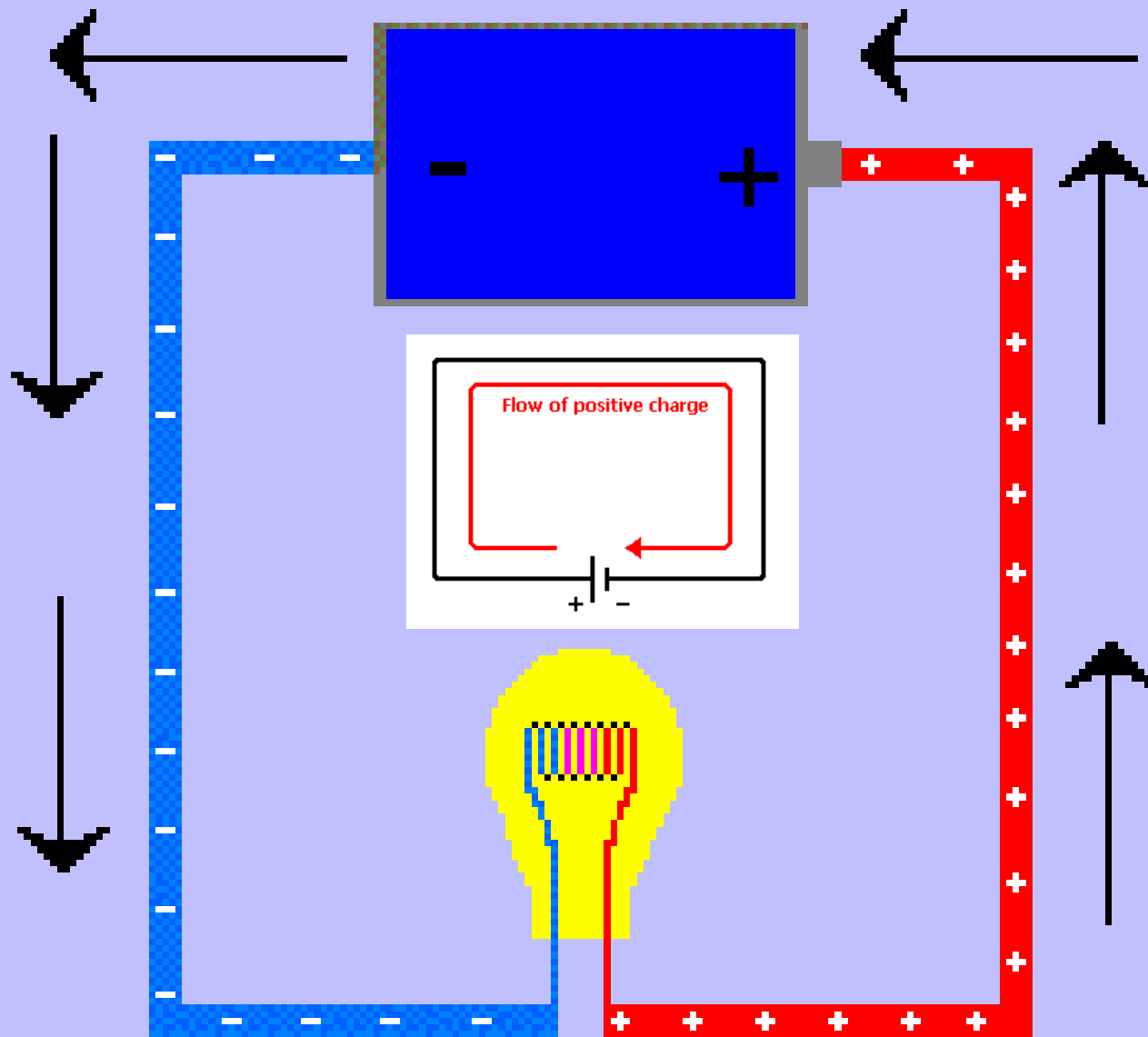

DC
Anyway!

Details Details

Symbol	Term	aka	Unit
E	Voltage	Electromotive Force	Volts (V)
I	Current	Rate of Flow	Amperes (A)
R	Resistance	--	Ohm (Ω)
P	Power	Rate of work	Watt (w)
W	Energy	Ability to do work	Watt-Second (Joule)

Ohm's Law

$$I = \frac{E}{R}$$

$$E = IR$$

$$R = \frac{E}{I}$$

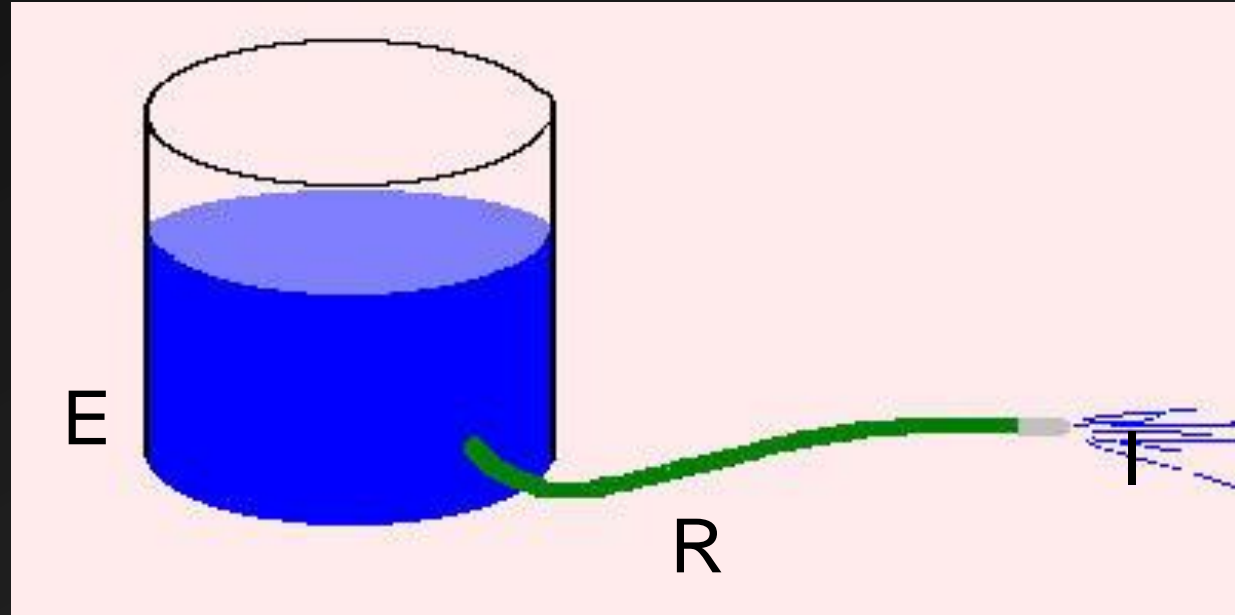

See also: <http://www.falstad.com/circuit/e-ohms.html>

Ohm's Law

$$I = \frac{E}{R}$$

$$E = IR$$

$$R = \frac{E}{I}$$

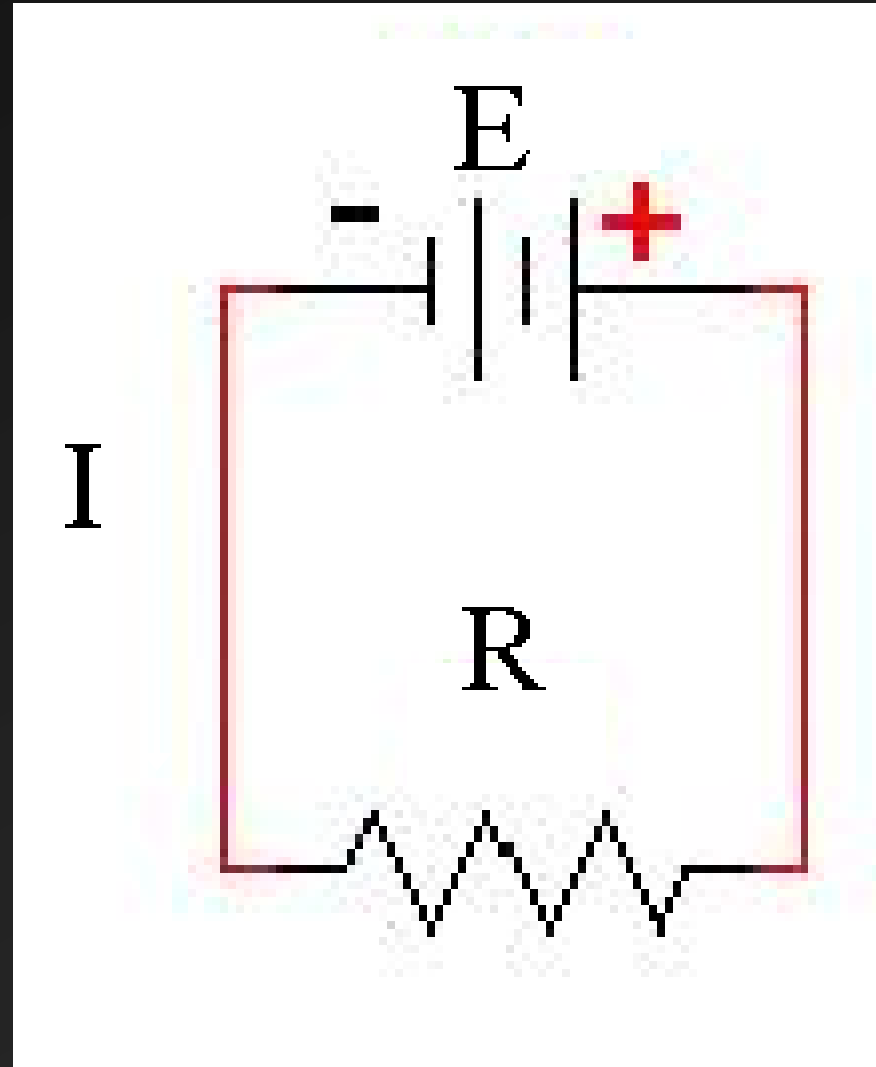

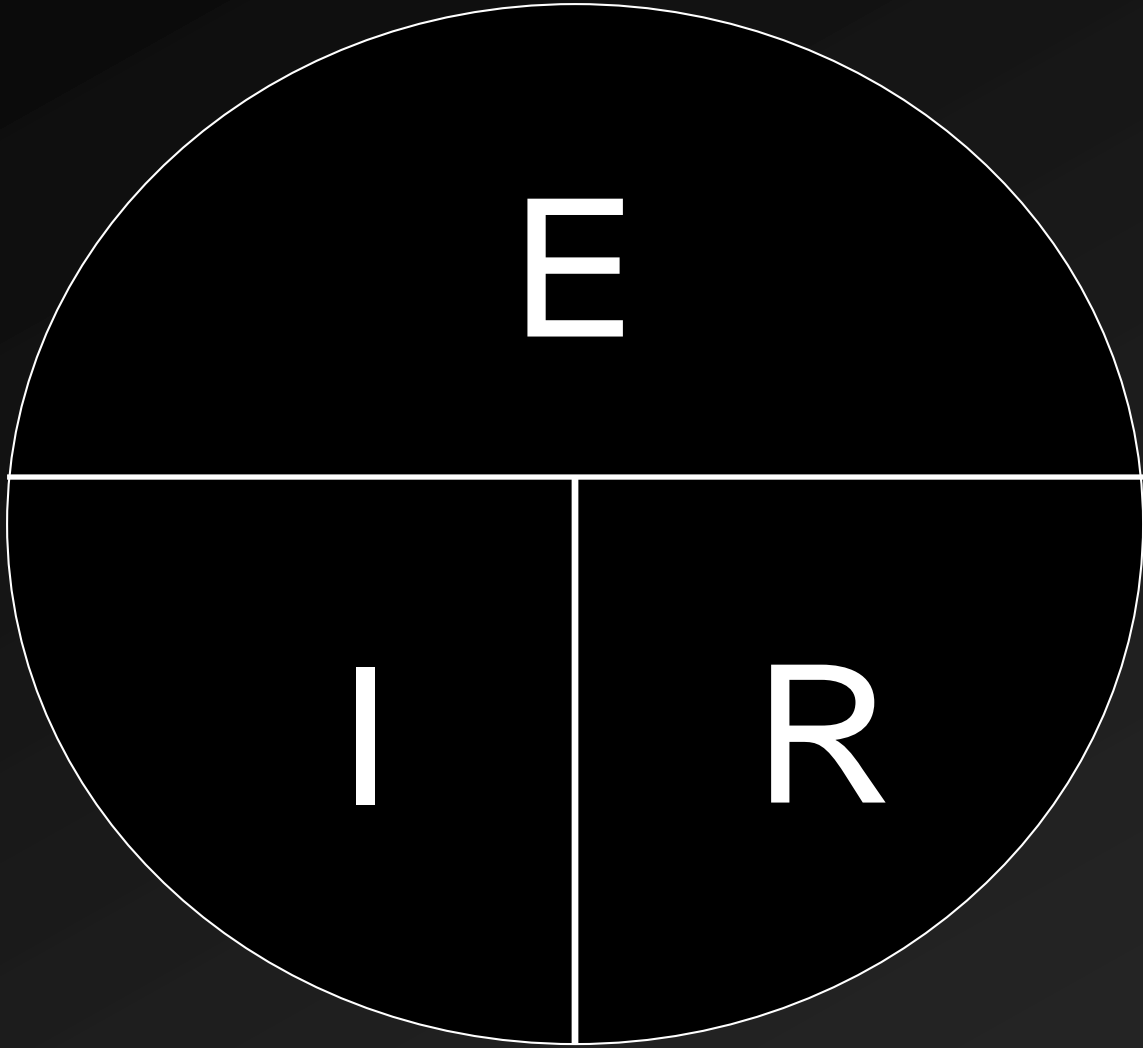

Ohm's Triangle

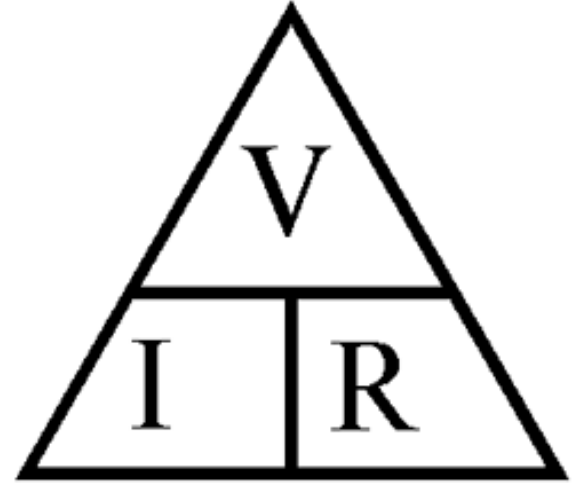

Cover the variable you want to find and perform the resulting calculation (*Multiplication/Division*) as indicated.

A black t-shirt is laid flat against a white background. The t-shirt has a crew neck and short sleeves. In the center of the chest, there is a white text design consisting of two lines of bold, sans-serif capital letters.

**RESISTANCE IS NOT FUTILE.
IT'S VOLTAGE DIVIDED BY CURRENT.**

Why are we talking about this stuff?

- We will be recording electrical signals!
- Spoiler alert: Neurons communicate using electrical principles
- Lab Safety
 - For how not to do this... <https://www.youtube.com/watch?v=FLY02JfcbPY>



Basic Circuit

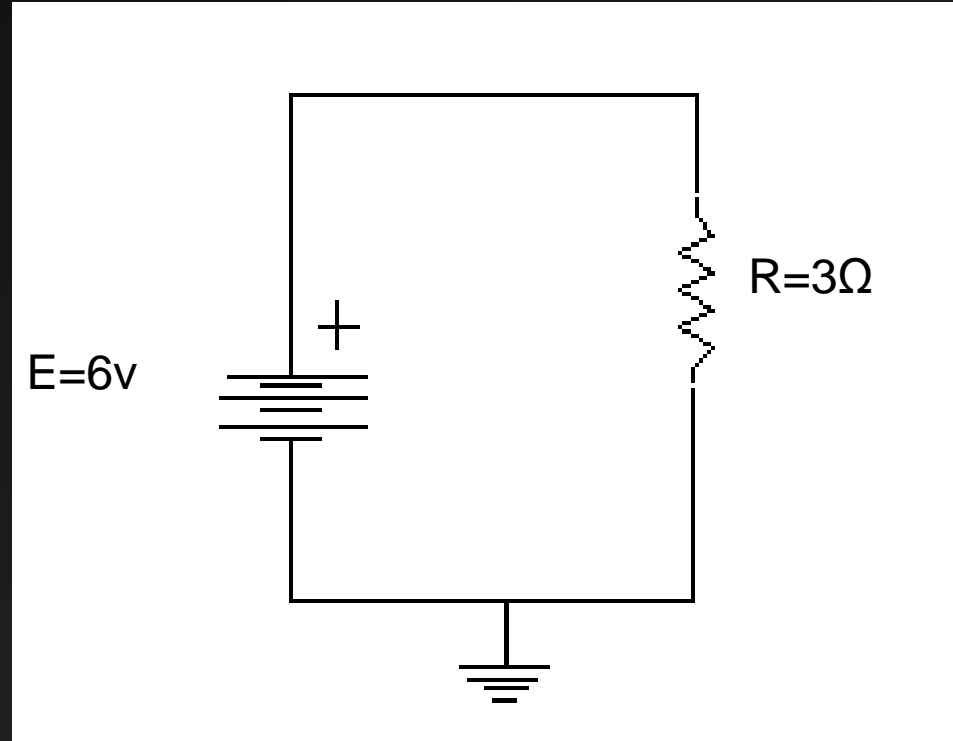
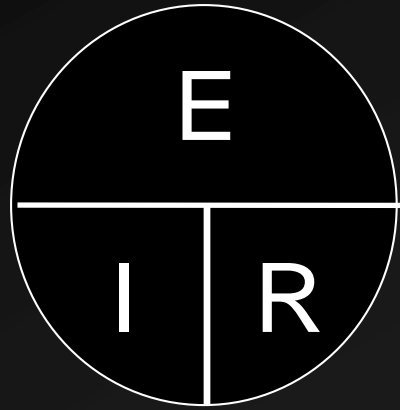

$$I = ?$$

Volt-Ohm Meter Demo



Series Circuit

$$R_T = R_1 + R_2$$

$$I = ?$$

$$E_{R1} = ?$$

$$E_{R2} = ?$$

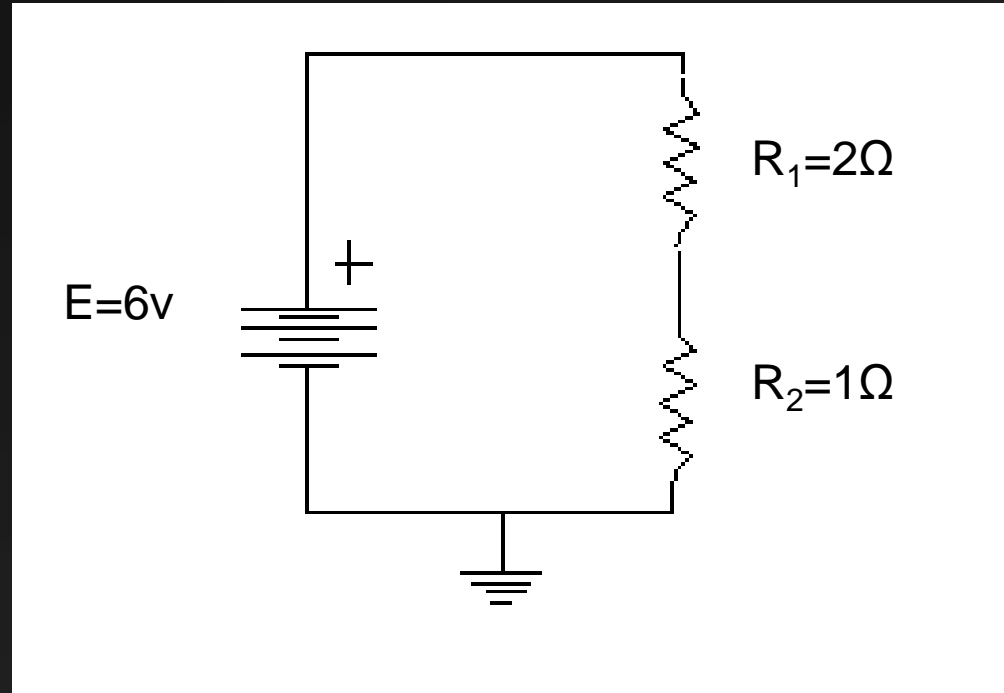

[Web Demo](#)

By Analogy: Series Vs Parallel

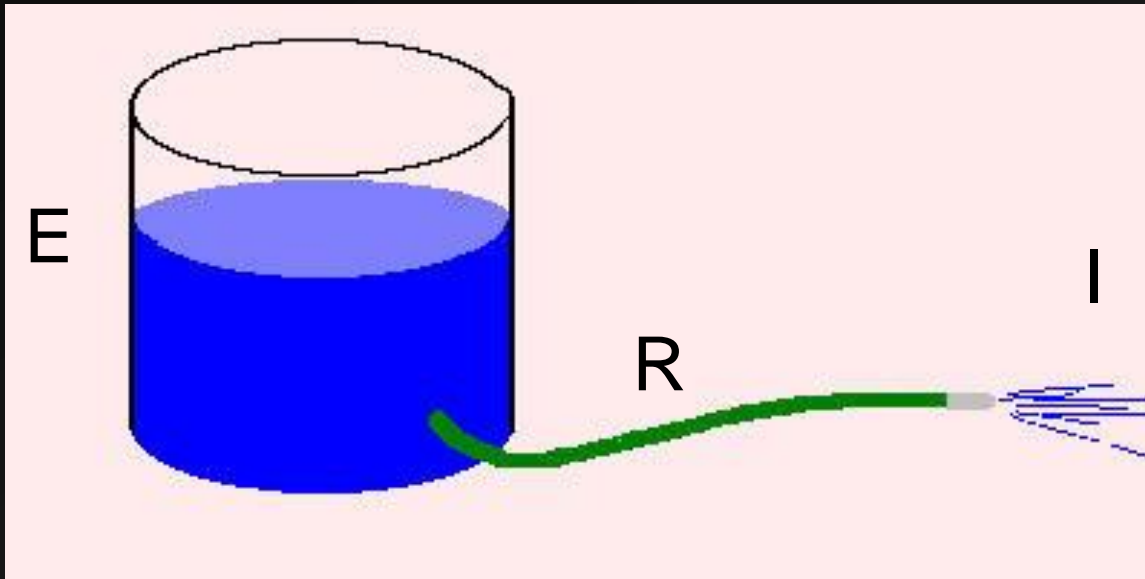

$$\frac{1}{R_T} = \frac{1}{R_1} + \frac{1}{R_2} + \frac{1}{R_3}$$

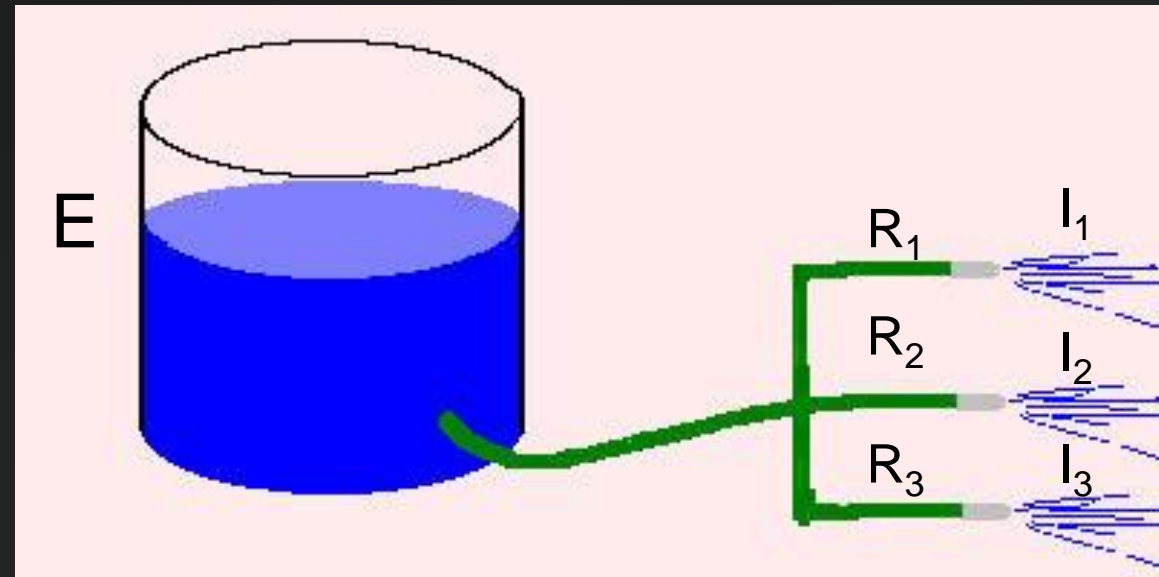

Parallel Circuit

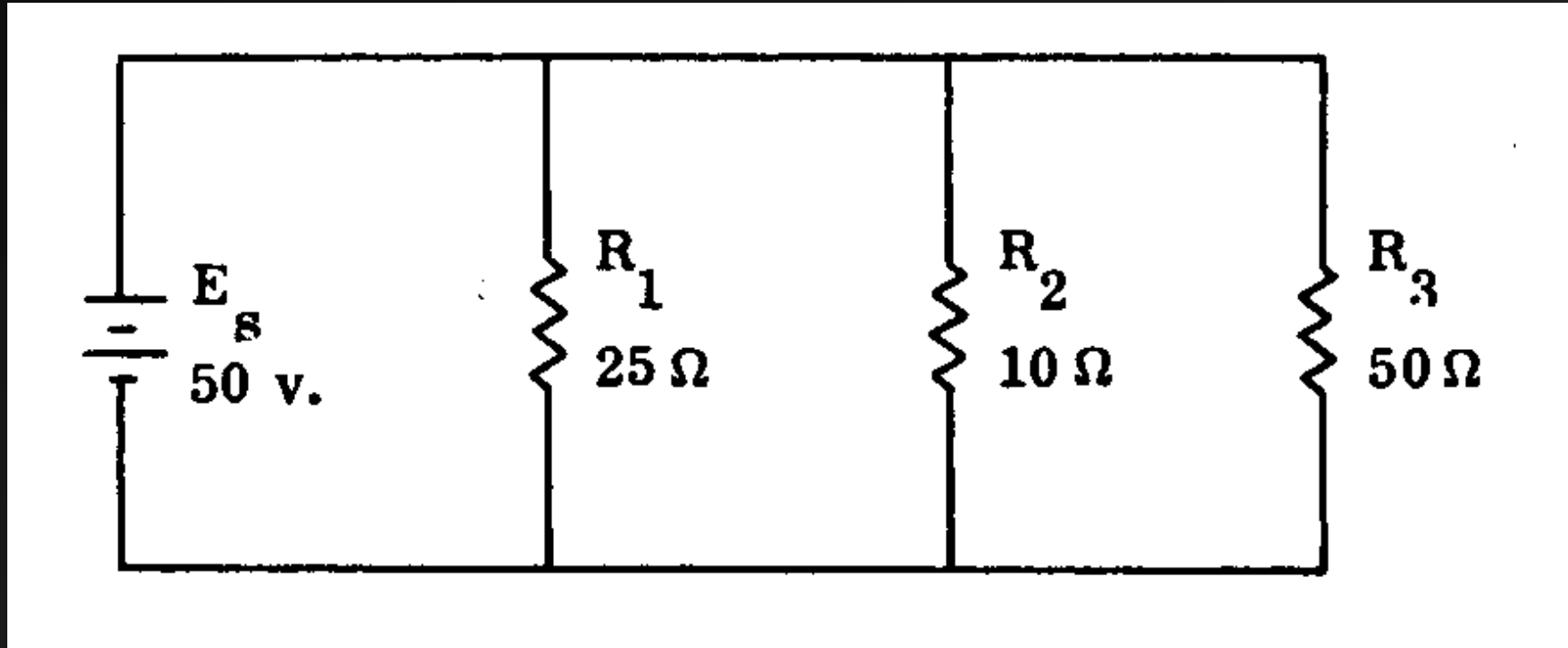

$$R_T = ?$$

$$I_1 = ?$$

$$I_3 = ?$$

$$I_T = ?$$

$$I_2 = ?$$

$$\frac{1}{R_T} = \frac{1}{R_1} + \frac{1}{R_2} + \frac{1}{R_3}$$

Complex Circuits

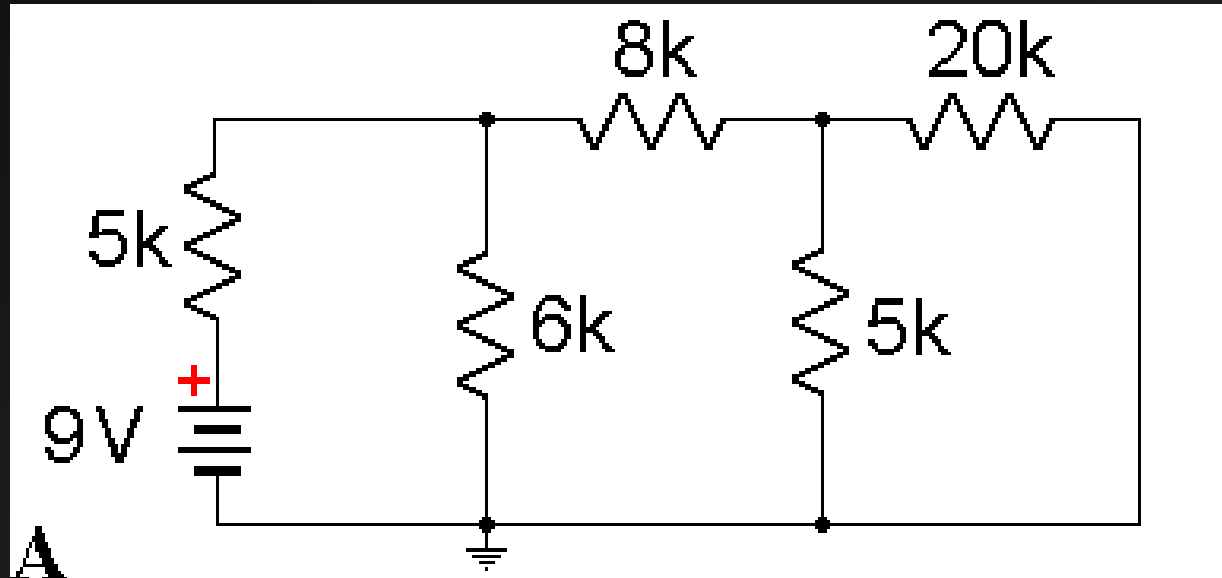

Find the current flowing in the circuit, and the voltage drops.

YIKES! Need to reduce. Start at the parallel combination of 20k and 5k resistors; it is replaced with its effective resistance of 4k

$$[1/R_{\text{equiv}} = 1/20 + 1/5 = 1/20 + 4/20 = 5/20 = 1/4].$$

This and subsequent slides on this circuit adapted from:

"<http://www.physics.udel.edu/~watson/phys345/examples/effective-circuit.html>"

Slightly less Complex Circuit

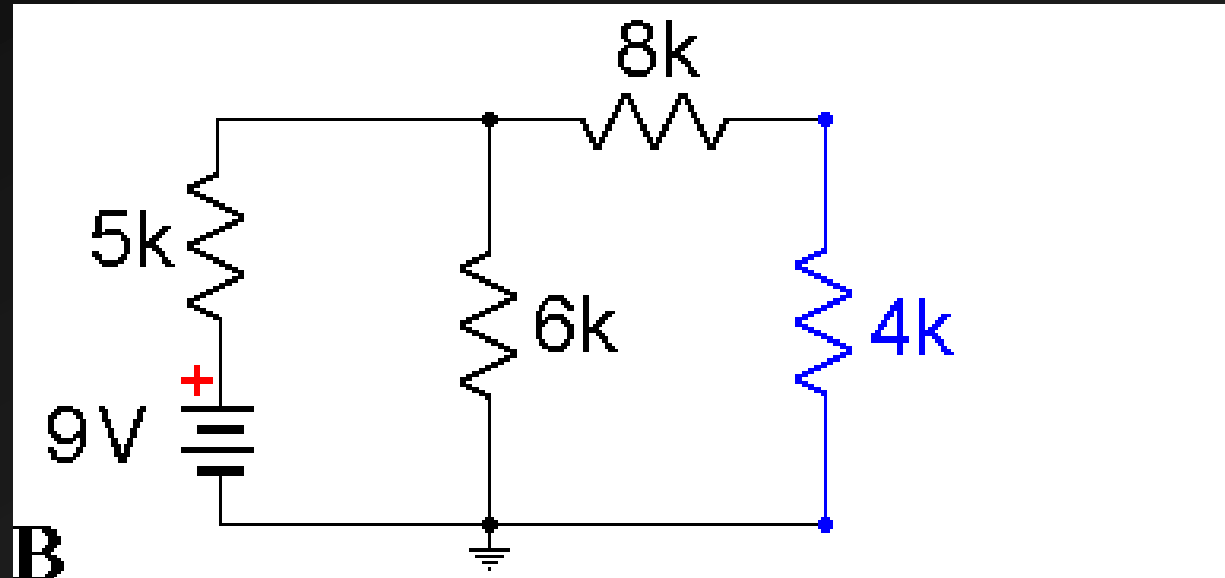

Looking Better. The effective resistance of 4k is in series with the actual resistance of 8k, leading to replacement by its effective resistance of 12k.
[$R_{\text{equiv}} = 4\text{k} + 8\text{k}$]

Less Complex Still

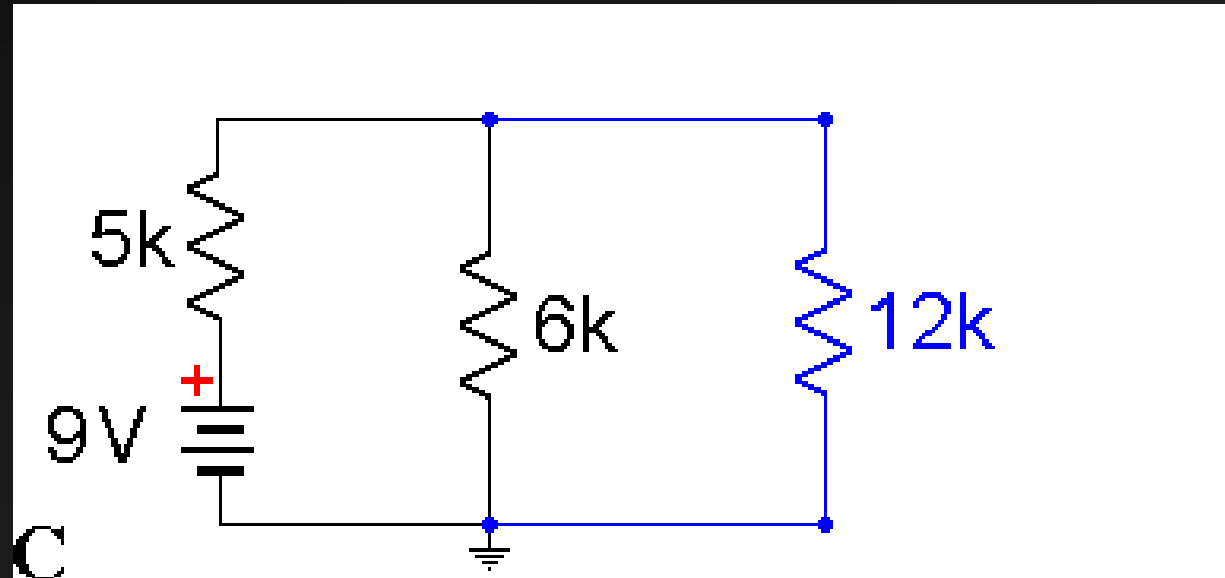

Better Still. Now there is a parallel combination of 12k and 6k resistors; it is replaced with its effective resistance of 4k
[$1/R_{\text{equiv}} = 1/12 + 1/6 = 1/12 + 2/12 = 3/12 = 1/4$].

Now Series: Almost Simple

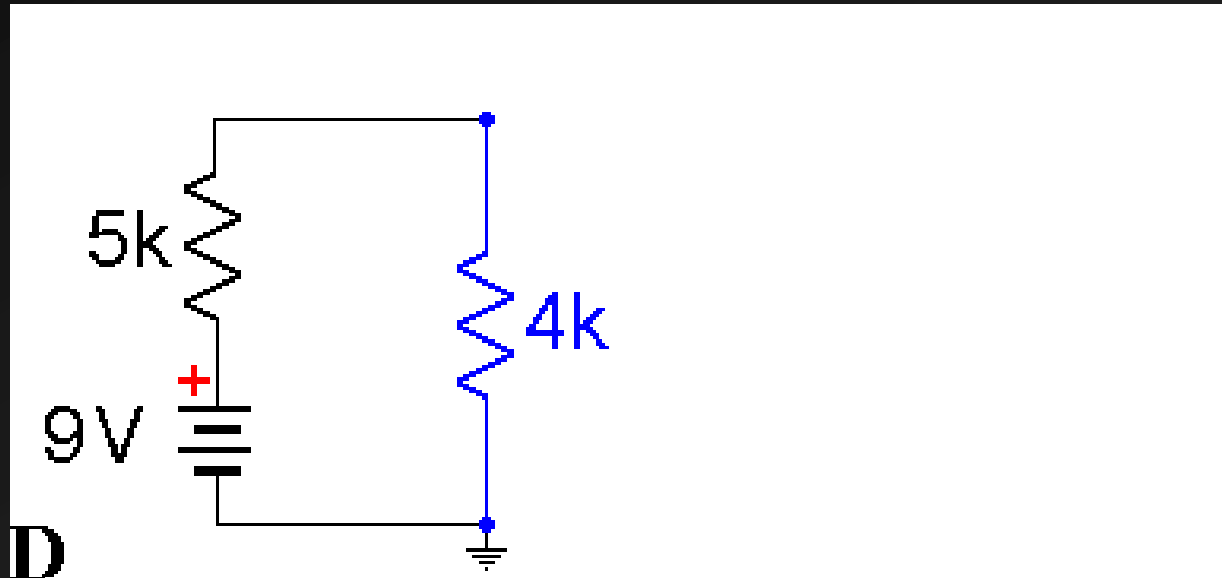

Now we have a simple series circuit!

Finally, the equivalent resistance for the entire circuit is 9k.

$$[R_{\text{equiv}} = 4\text{k} + 5\text{k}].$$

Now Series: Almost Simple

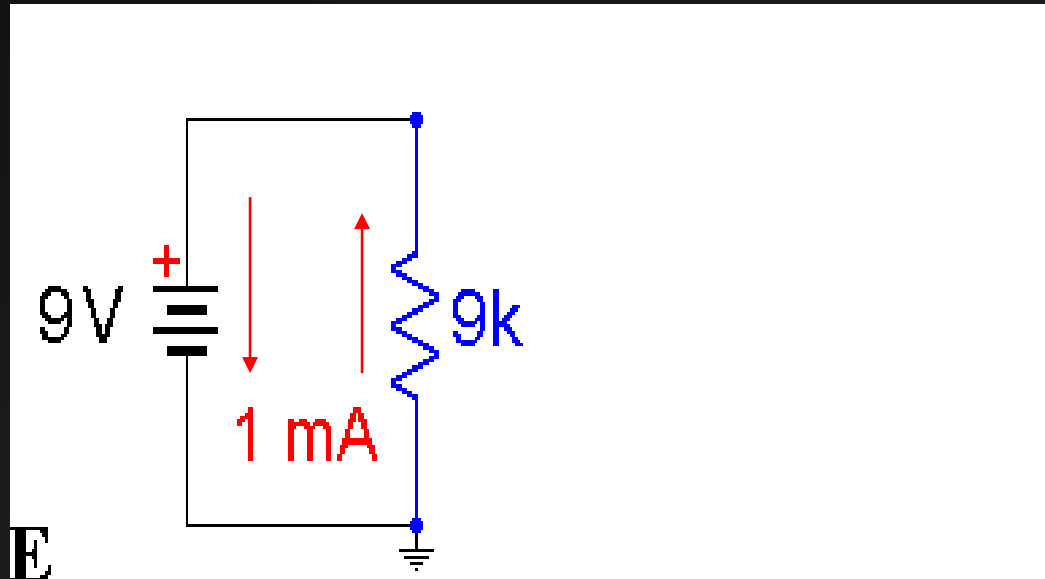

$I = ?$

$$[I = E/R = 9 \text{ V}/9 \text{ k} = 1 \text{ mA}]$$

Working Back: Voltage Drops and Current

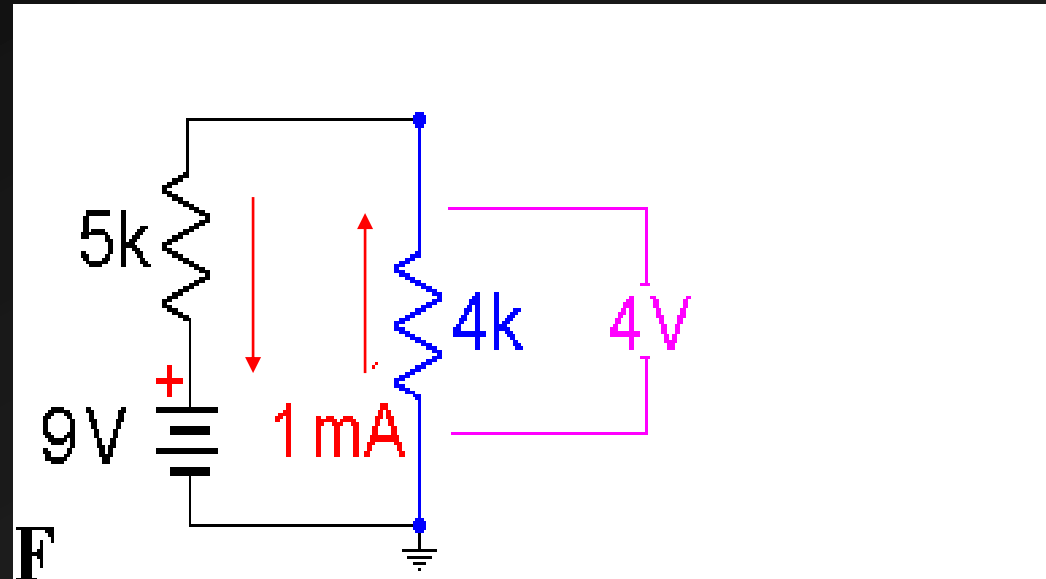

The real 5k resistor and the effective 4k resistance each have 1 mA of current since they are in series. Thus the 4k resistance has 4V of voltage difference across it (by Ohm's law).

Working Back: Voltage Drops and Current

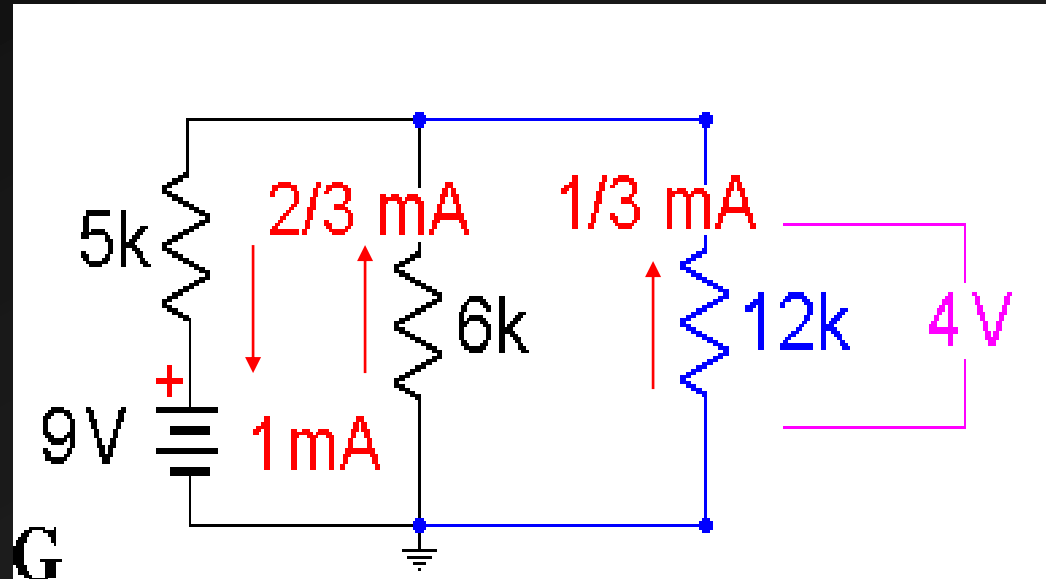

Breaking the 4k resistance into its component parts (in parallel), we find that $2/3$ mA of current flows in the 6k resistor and $1/3$ mA flows in the effective resistance of 12k.

$$I = E/R = 4/6K = 2/3 \text{ mA}$$

$$I = E/R = 4/12K = 1/3 \text{ mA}$$

Working Back: Voltage Drops and Current

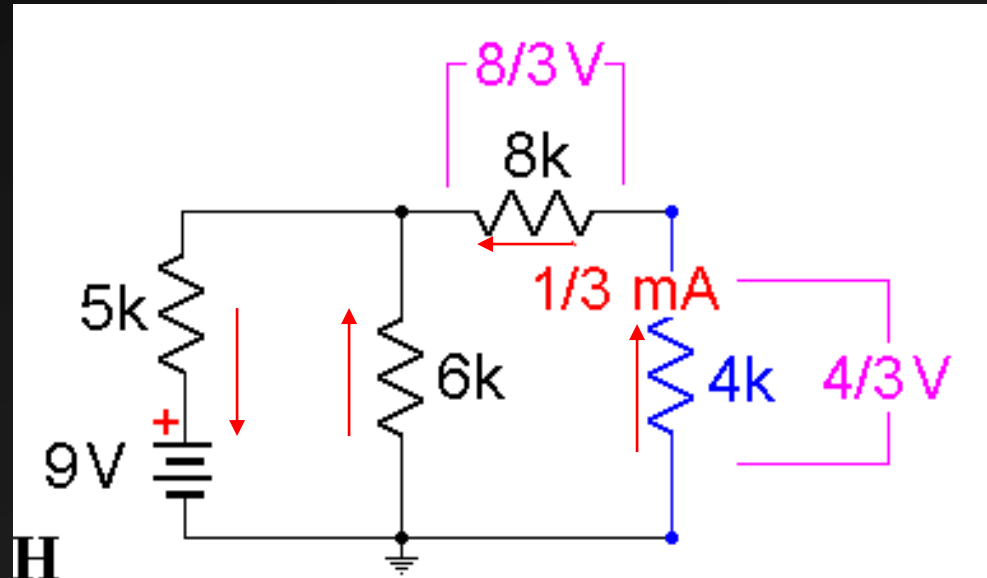

Breaking the 12k resistance into its component parts (in series), we find that there is $8/3$ V across the 8k resistor and $4/3$ V across the effective resistance of 4k.

$$E = IR = 4K\Omega * 1/3 \text{ mA} = 4/3 \text{ V}$$

$$E = IR = 8K\Omega * 1/3 \text{ mA} = 8/3 \text{ V}$$

Working Back: Voltage Drops and Current

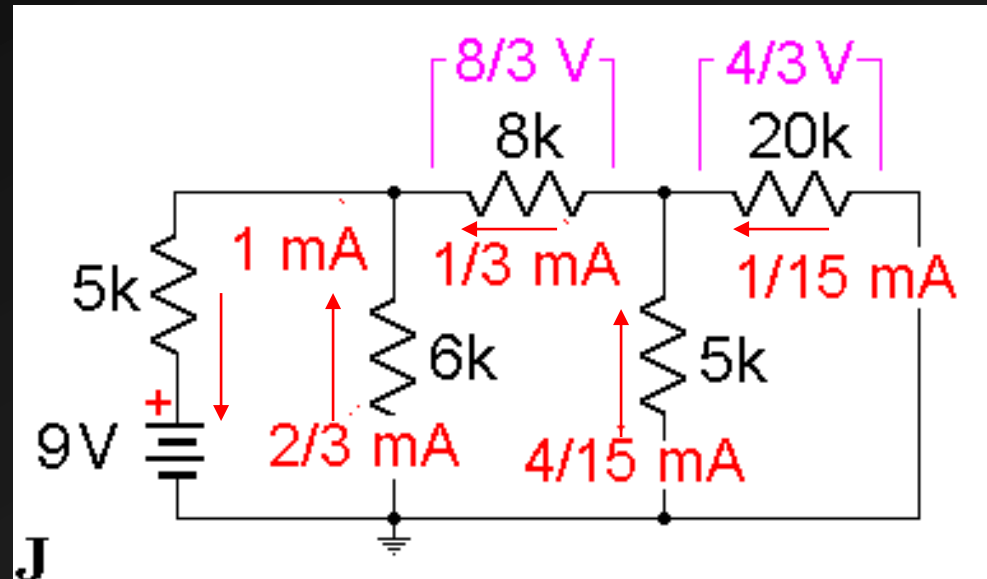

Finally, breaking the 4k resistance into its component parts (in parallel), we find that 1/15 mA of current flows in the 20k resistor and 4/15 mA flows in the 5k resistor.

$$I = E/R = (4/3V)/20K\Omega = 4/60 \text{ mA} = 1/15 \text{ mA}$$

$$I = E/R = (4/3V)/5K\Omega = 4/15 \text{ mA}$$

Working Back: Voltage Drops and Current

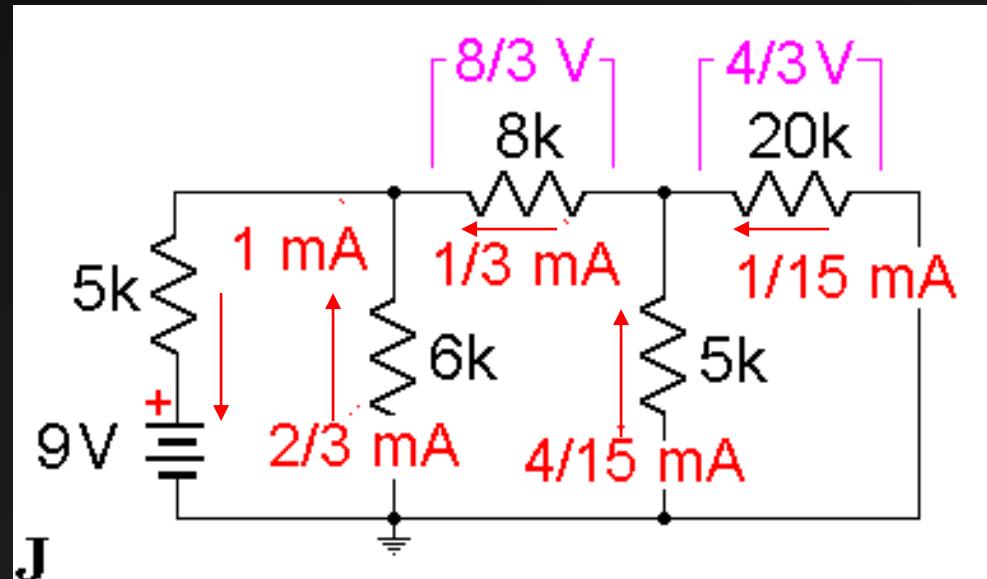

Summarizing:

- | | |
|--|--------|
| 1. Current through the battery? | 1 mA |
| 2. Current through the 8k resistor? | 1/3 mA |
| 3. Voltage difference across the 20k resistor? | 4/3 V |

In Real Life...

B. MARSHALL-GOODELL, L. TASSINARY, AND J. CACIOPPO

a) Series Circuit

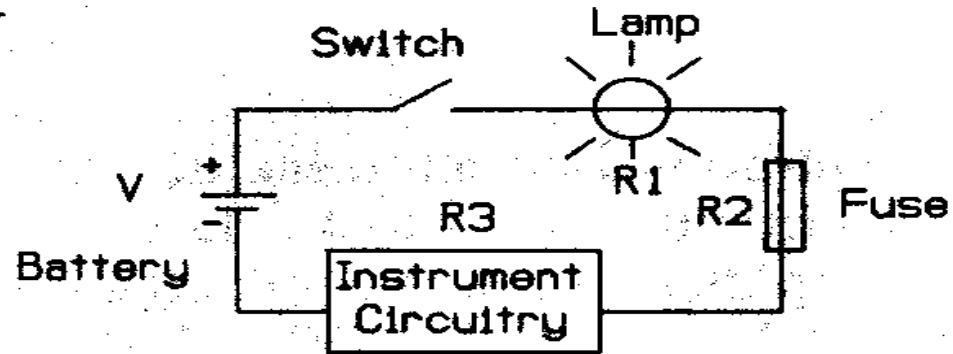

b) Parallel Circuit

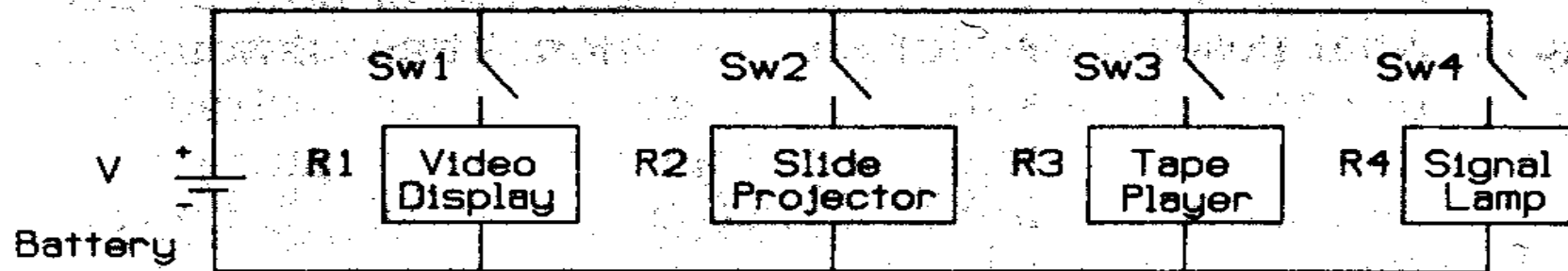

Capacitance

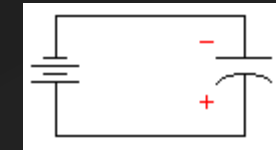
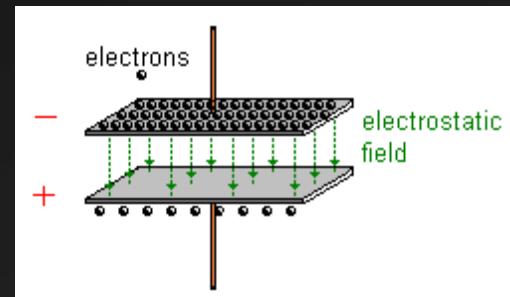
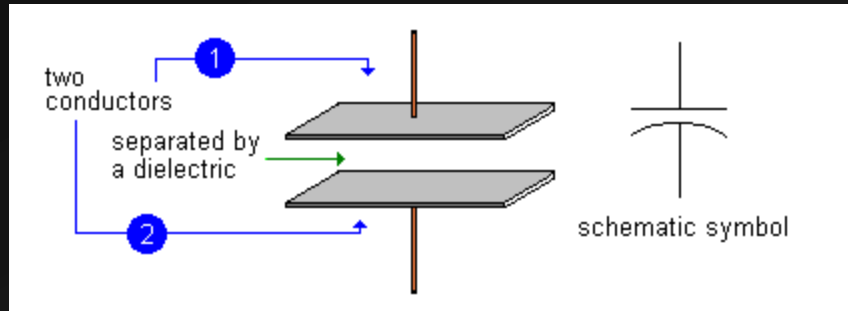

Capacitor = two conductors separated by a dielectric.

Dielectric = material that is a good insulator (incapable of passing electrical current), but is capable of passing electrical fields of force. Examples include glass, porcelain.

Charged Capacitor = more electrons on one conductor plate than on the other.

Capacitance

- Two closely spaced plates – offer essentially no resistance



- As negative charge built up on first plate due to flow of electrons, a positive charge would build up on second plate
 - The current **charges** the plates of the capacitor, **but does not flow through the capacitor**, itself.

Capacitance

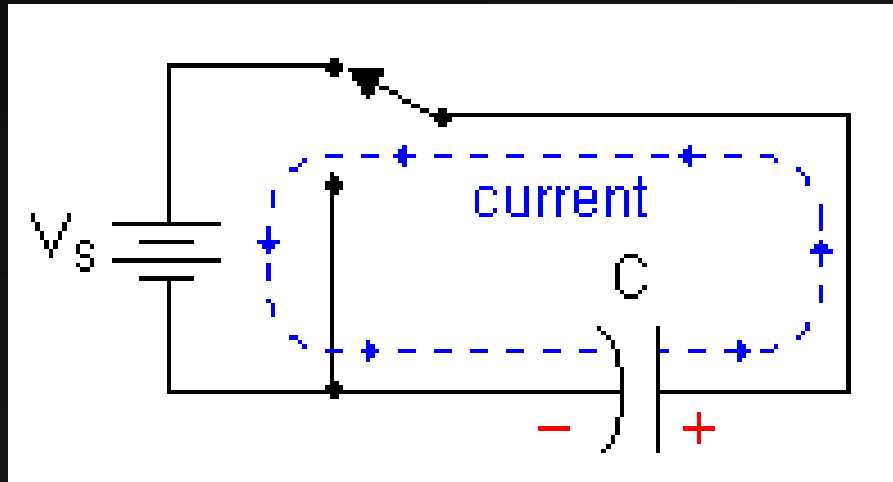

Charging – current flows until capacitor is fully charged, then stops

Discharging – current flows in reverse direction until capacitor fully discharged

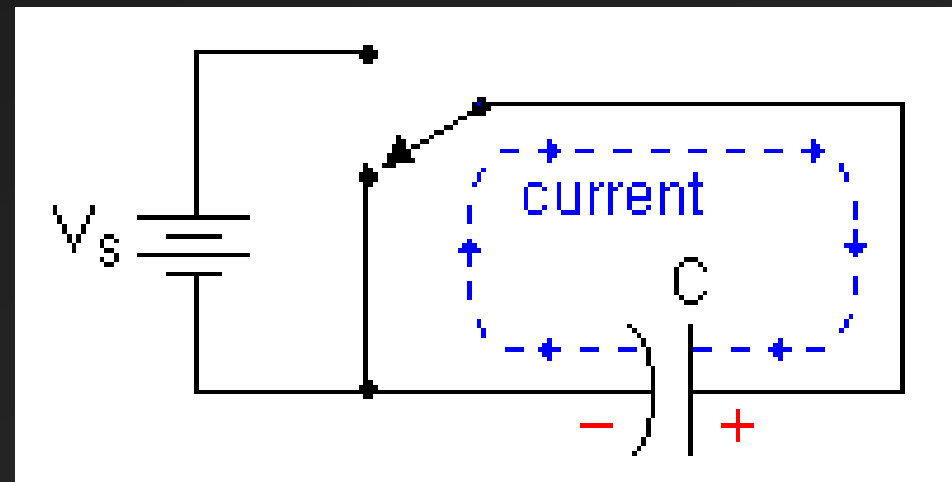

Capacitance – Size Matters

➤ Which has more capacity?



➤ More capacity, more current flows before capacitor is fully charged

Capacitor Time Constants

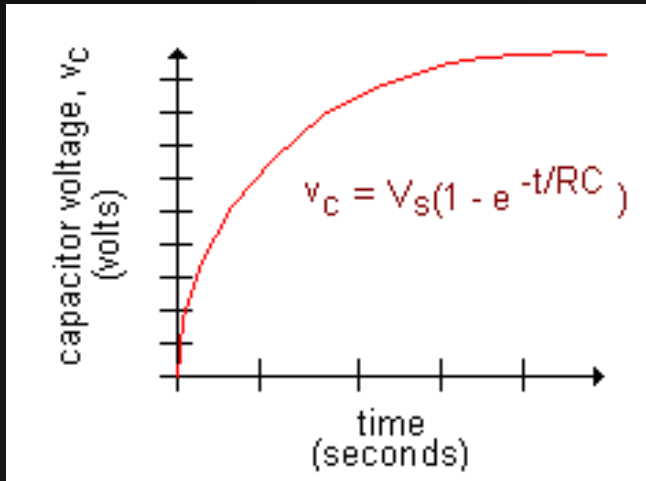

Over time...

Capacitor's voltage increases

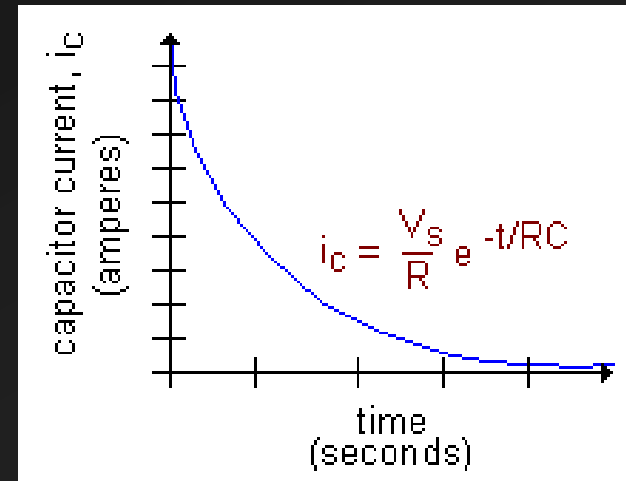

Current flow grinds to a halt

The capacitor's time constant $TC =$

- The time in seconds for it to become 63.2% charged
- The time in seconds for current flow have slowed by 63.2% from its starting value

AC Circuits

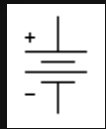

DC Circuit: Current Flow is unidirectional, from
– to +



AC Circuit: Current Flow switches direction
periodically (at a given frequency in Hz)

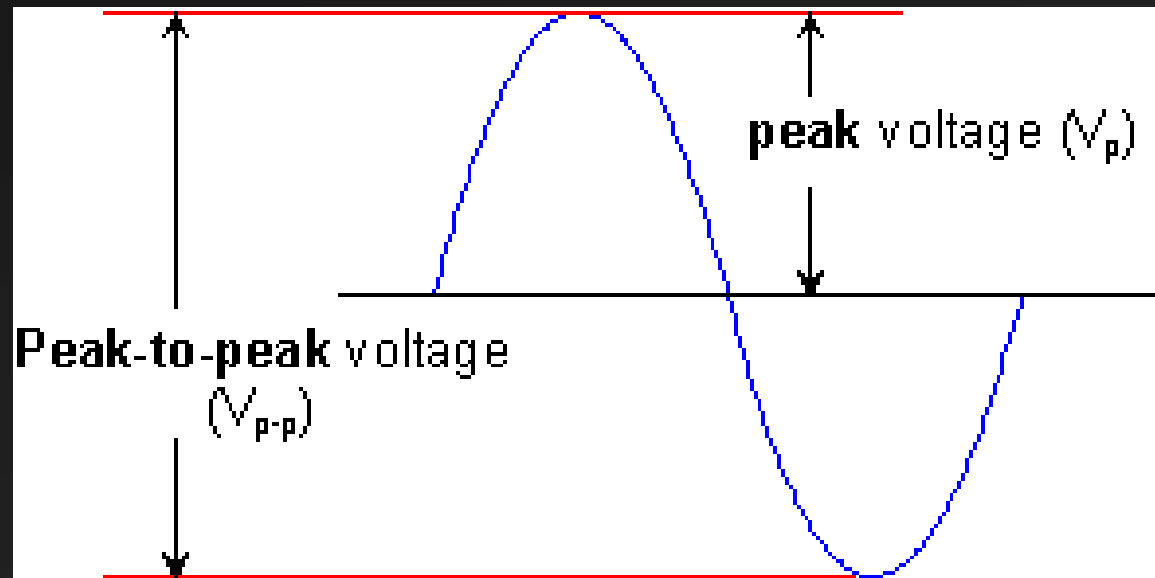

AC Circuits and Capacitance

- Slowly alternating signals
 - will fully charge capacitor, and signal will be impeded
- Rapidly alternating signals
 - will not fully charge the capacitor before the direction of flow reverses, allowing signals to pass unimpeded

<http://micro.magnet.fsu.edu/electromag/java/capacitor/>

<https://www.youtube.com/watch?v=aolH0aTnOhk>

Using Capacitors to make Low Pass Filters

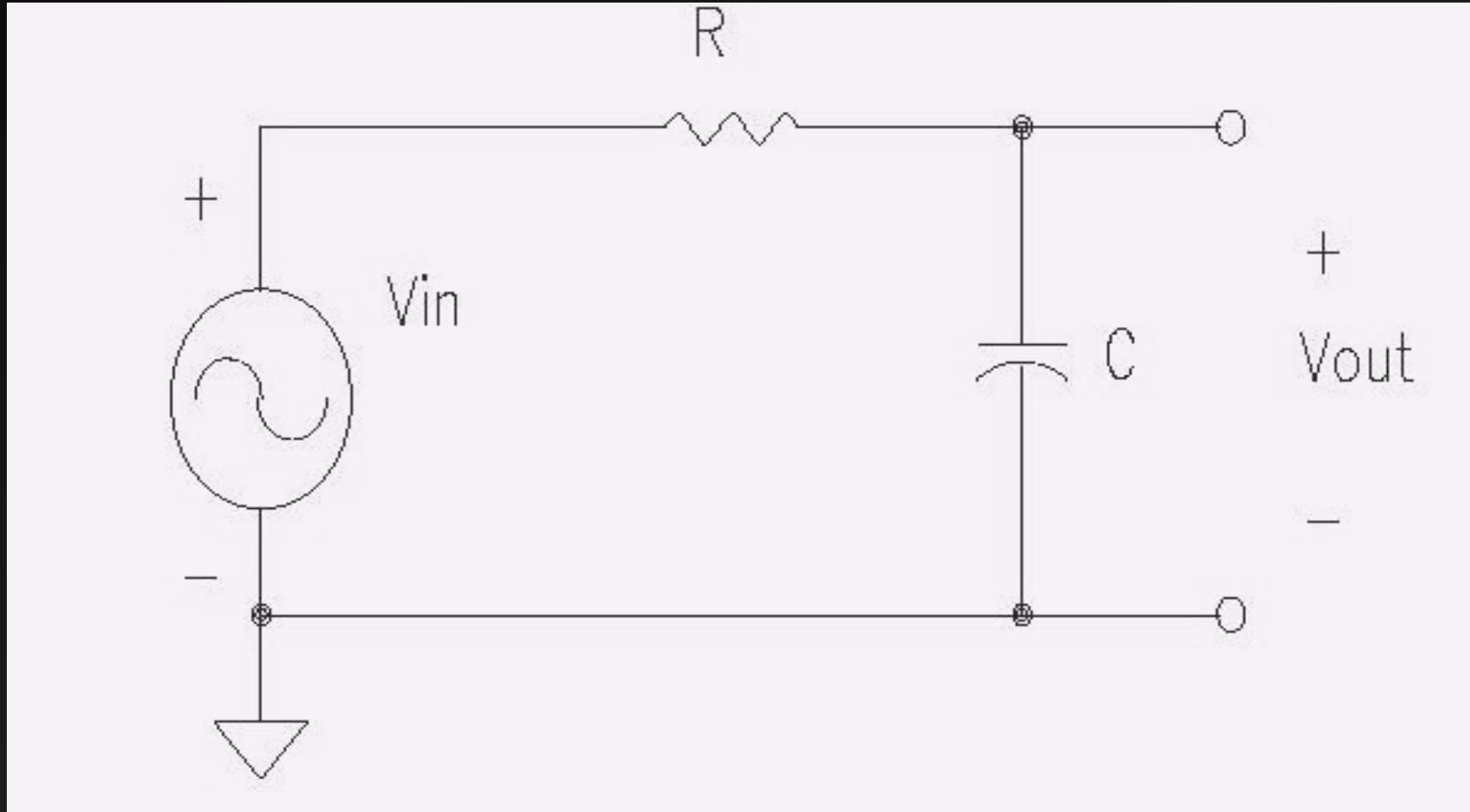

What will happen to fast signals; slow signals?

Using Capacitors to make High Pass Filters

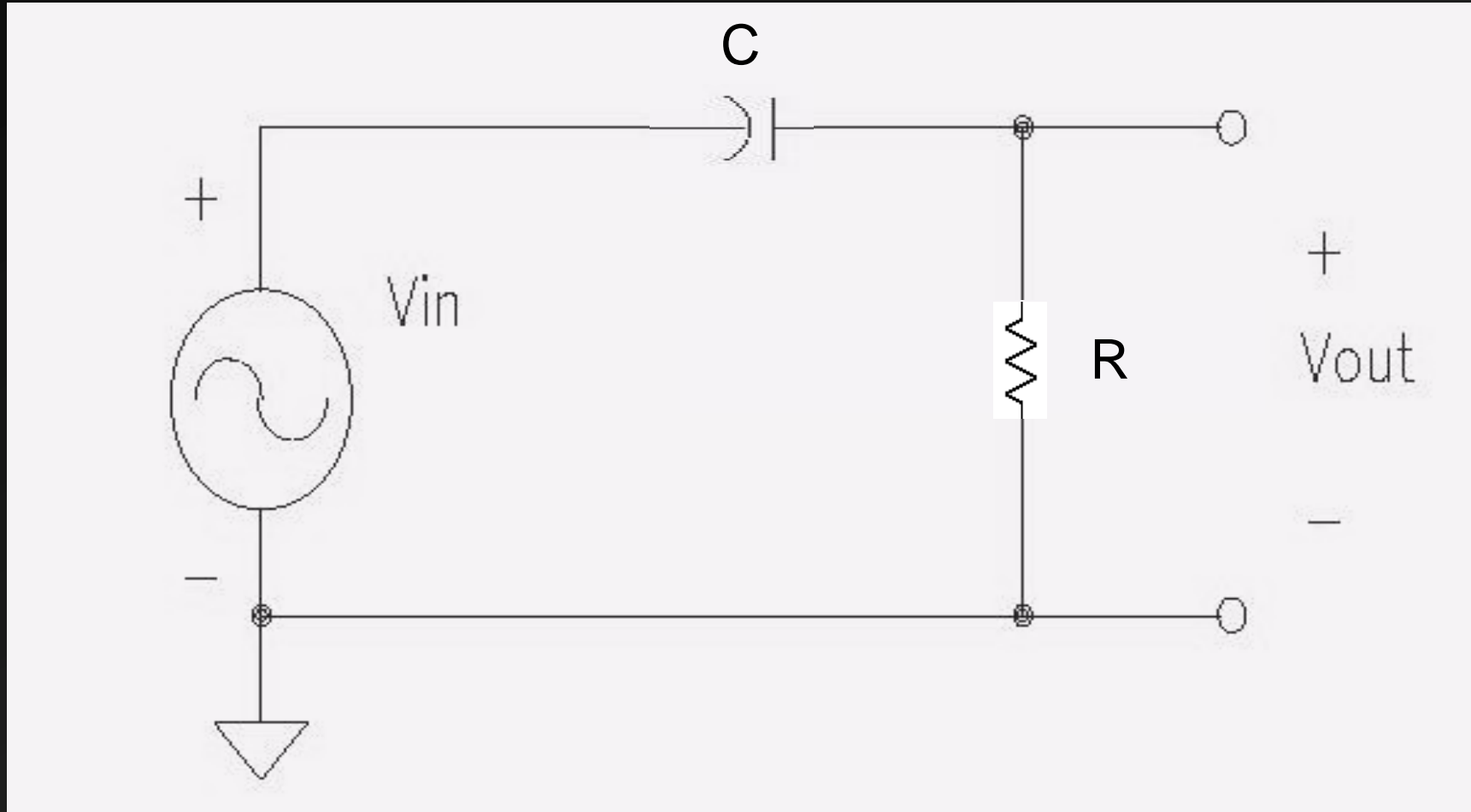

What will happen to fast signals; slow signals?

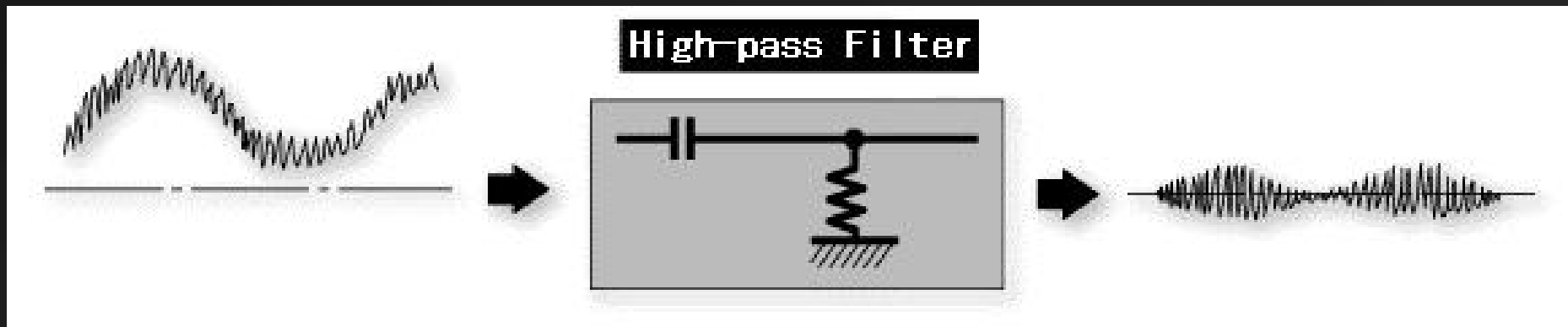
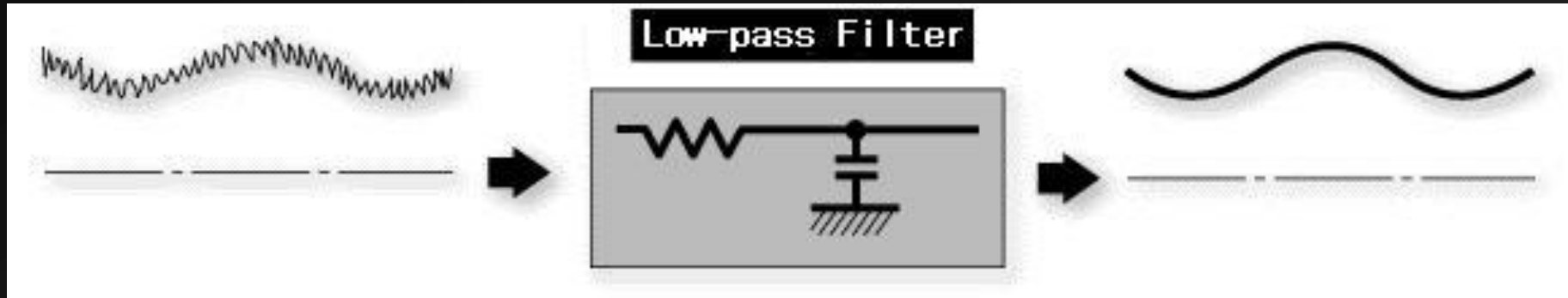

Part II: Basic Neurophysiology

- Three basic units inside the brain
 - Glial cells
 - Extracellular space: not really space
 - The neuron
 - Three types:
 - Sensory
 - Motor
 - Interneuron

Withdrawal Reflex

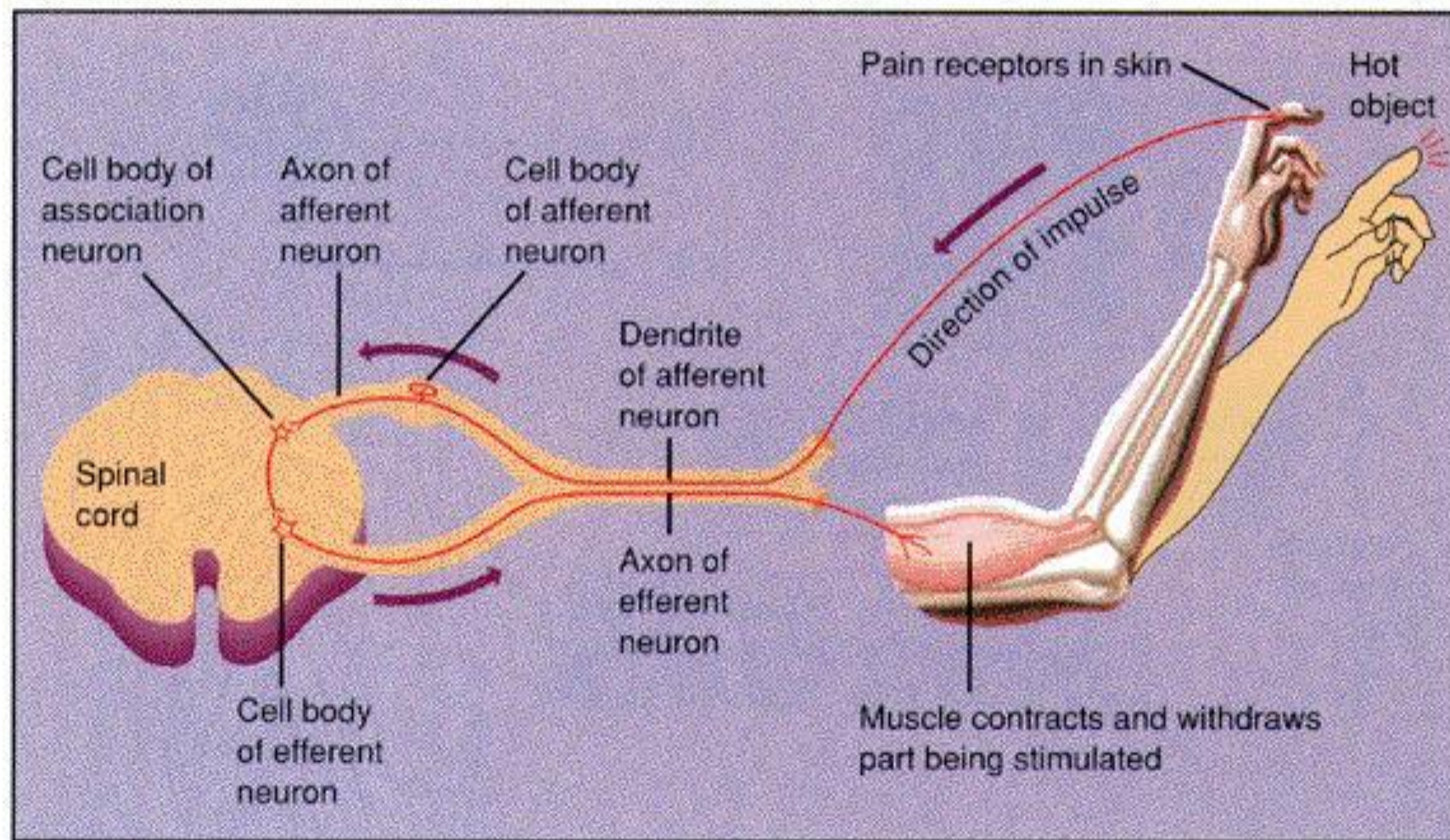

The Common Household Neuron

- Vary widely, but all have:
 - Cell body (soma)
 - Dendrites
 - Axon
 - Myelin sheath
 - Nodes of Ranvier
 - Microtubules
 - Terminal buttons (AKA synaptic knob)
- Nerve = a bundle of axons

[Jump to Next](#)

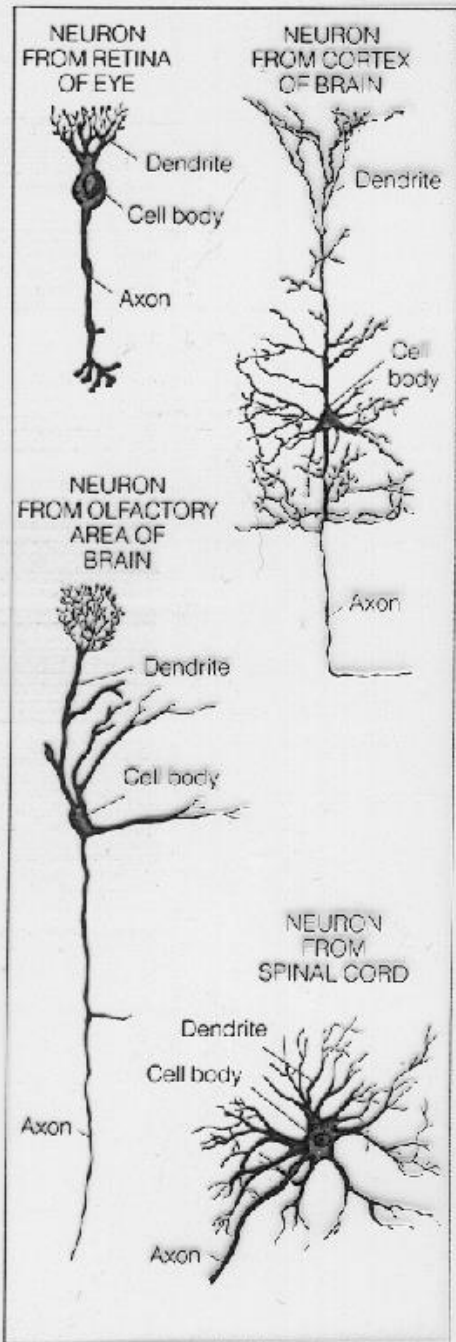

Neuron Structure

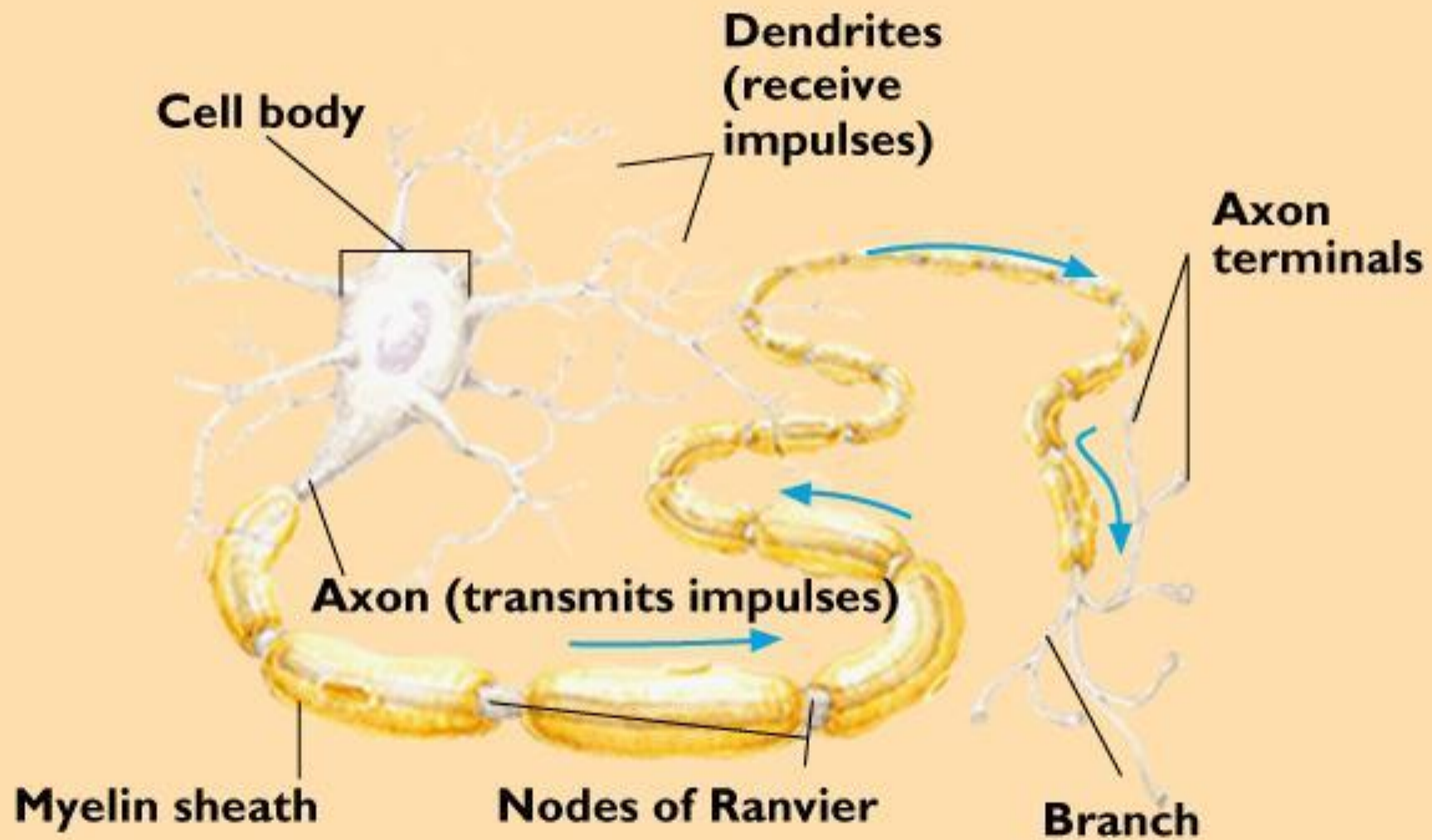

Myelin Sheath

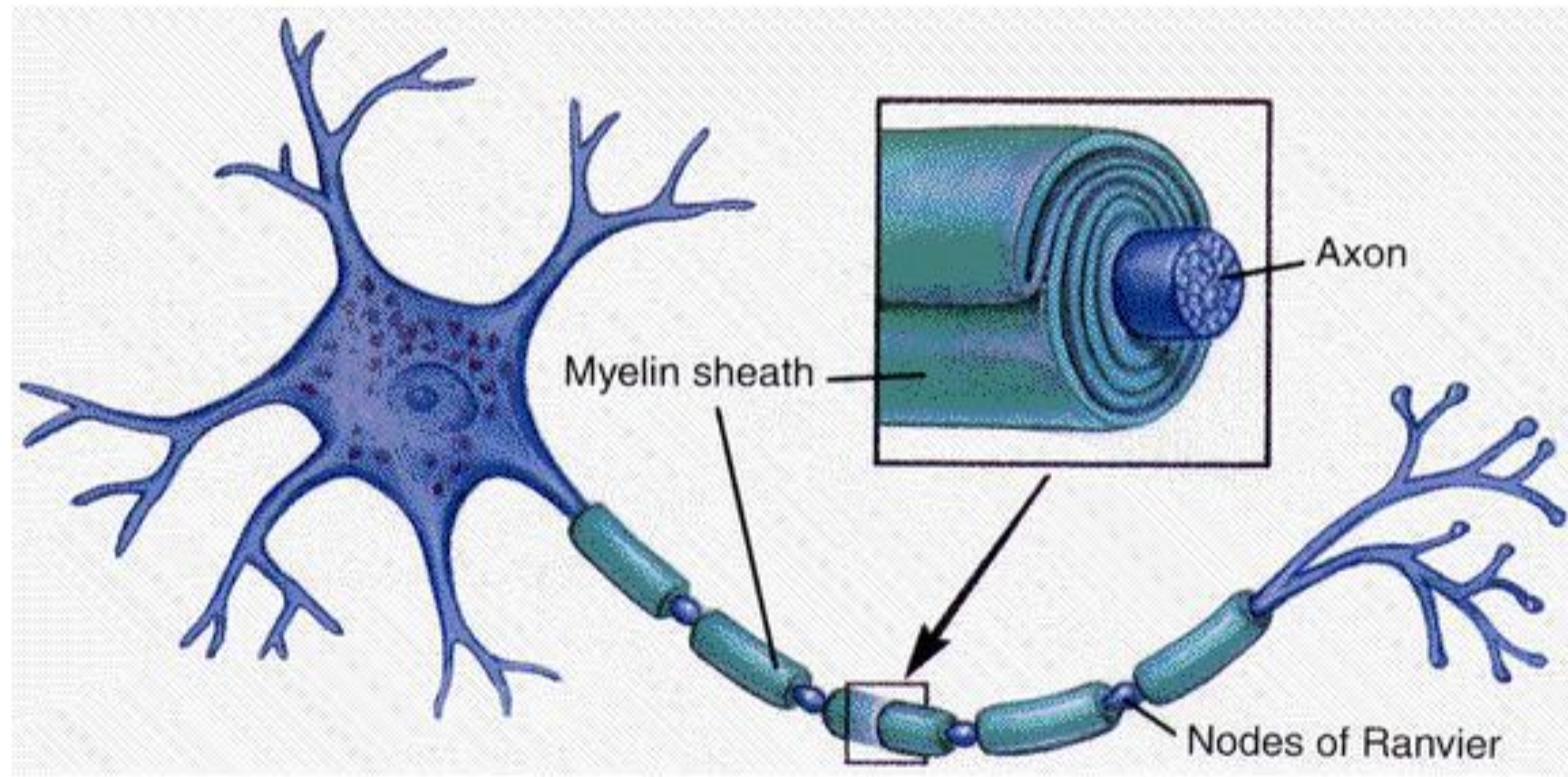

The Synapse

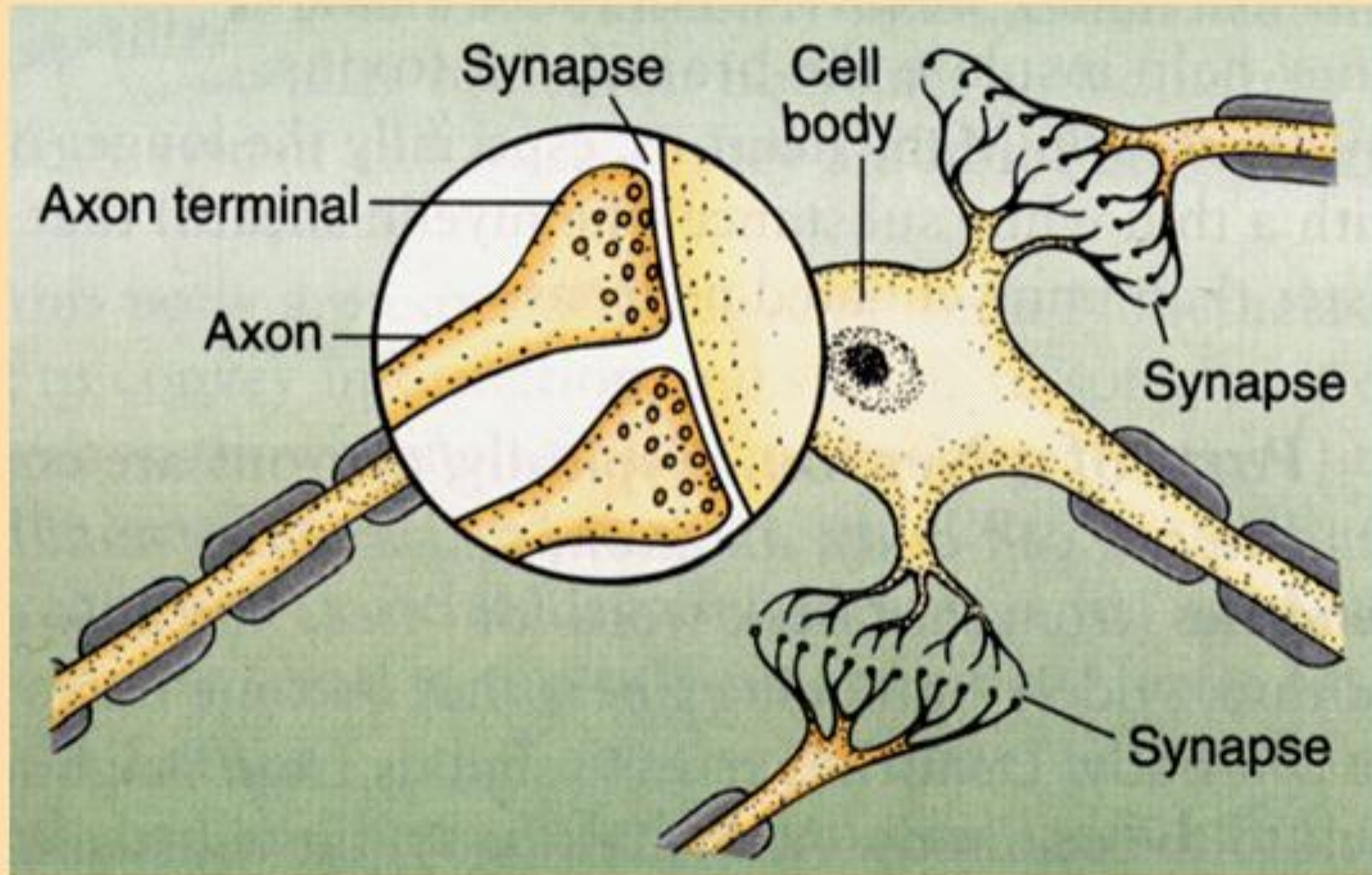

Neural Communication

- Axonal Conduction (electro-chemical)
- Synaptic Transmission (chemico-eletrical)

Axonal Conduction

- Resting potential
 - Inside of cell slightly negative
 - Two forces act upon these ions
 - Concentration gradient--osmotic force
 - Electromotive force
 - Equilibrium potential:
 - $E_{ion} = (R*T/z*F) * \ln(\text{Conc}_{Ex}/\text{Conc}_{In})$
 - where R is gas constant, T is temperature, z is ionic valence, and F is Faraday's constant.
- The Hodgkin & Huxley Model

Axonal Conduction

➤ Depolarization

➤ Threshold

➤ Axon Hillock

➤ Na ions rush in resulting in:

➤ Action potential;

➤ All or none phenomenon, high frequency

➤ Afterpotentials; hyperpolarizing, depolarizing; slow frequency

➤ Changes in membrane permeabilities

➤ Propagation

➤ Refractory period

[Jump to Next](#)

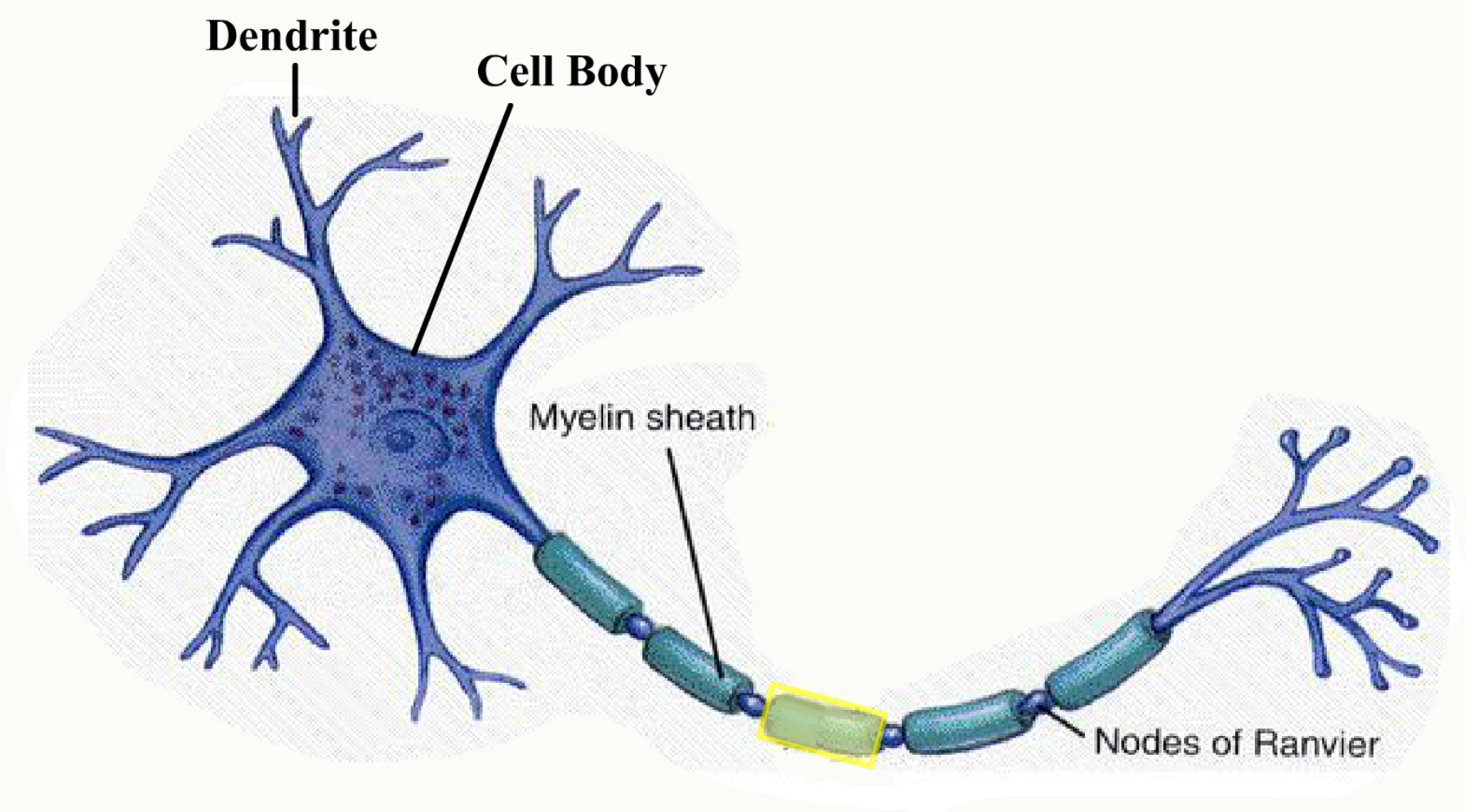

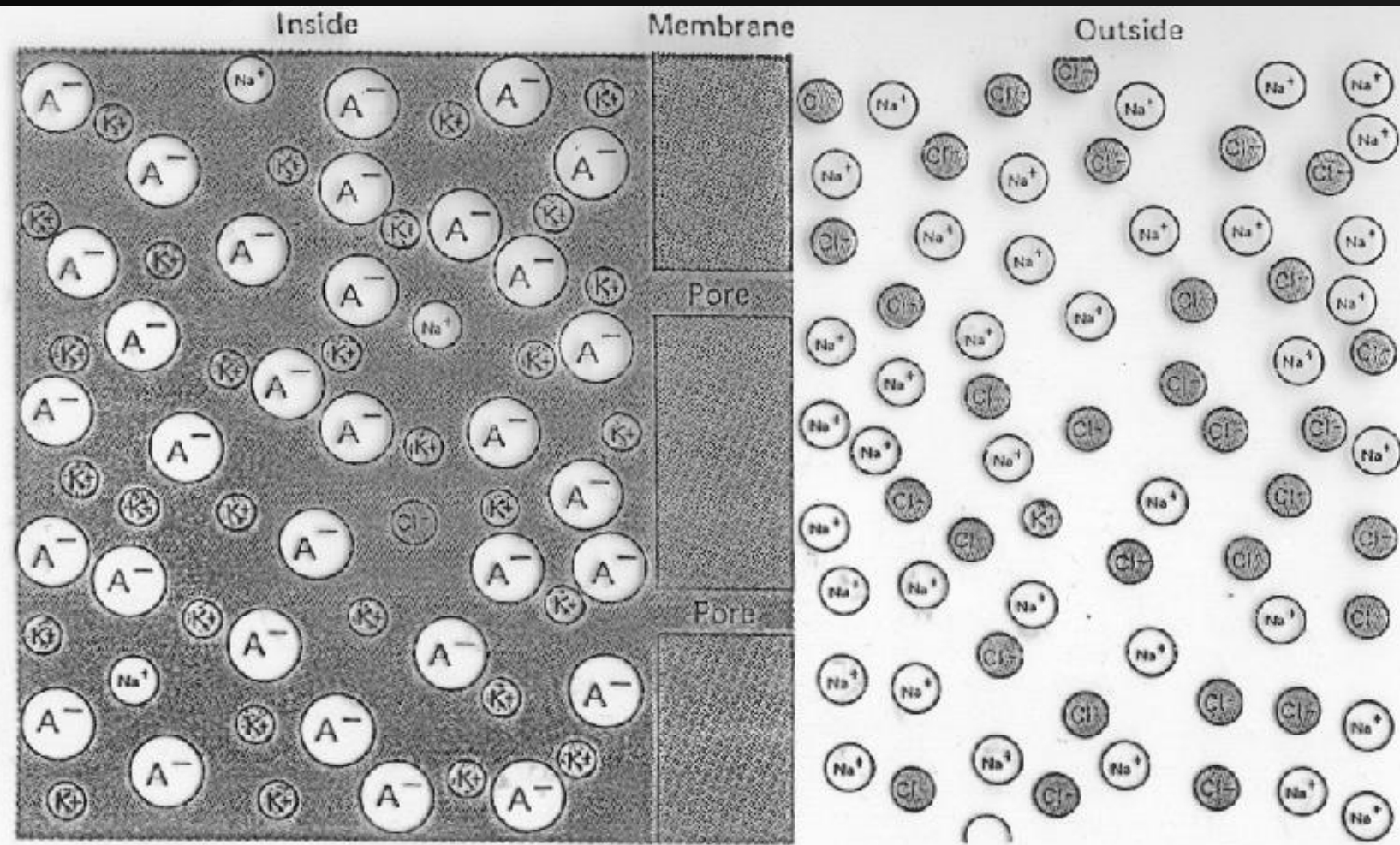
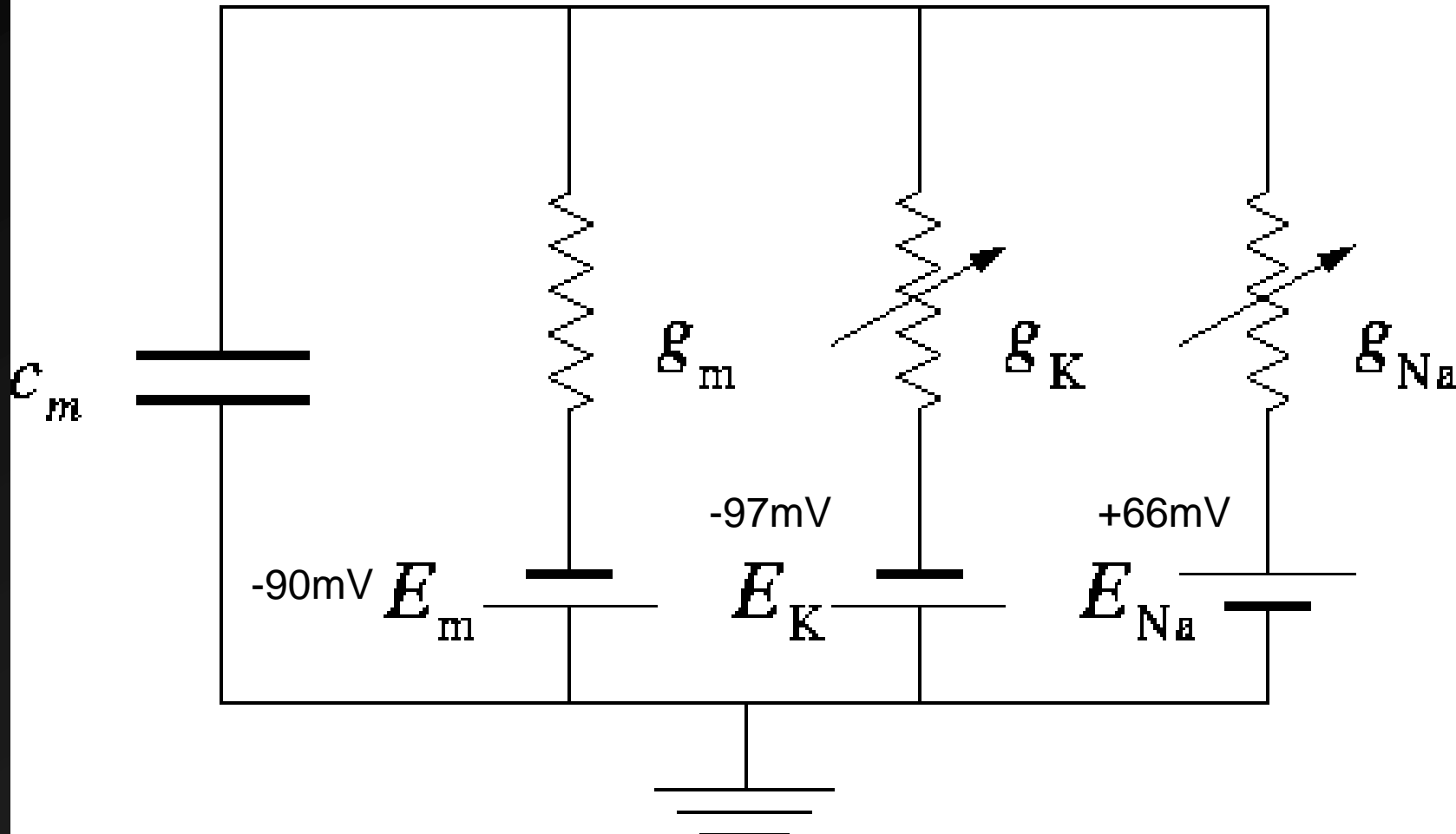
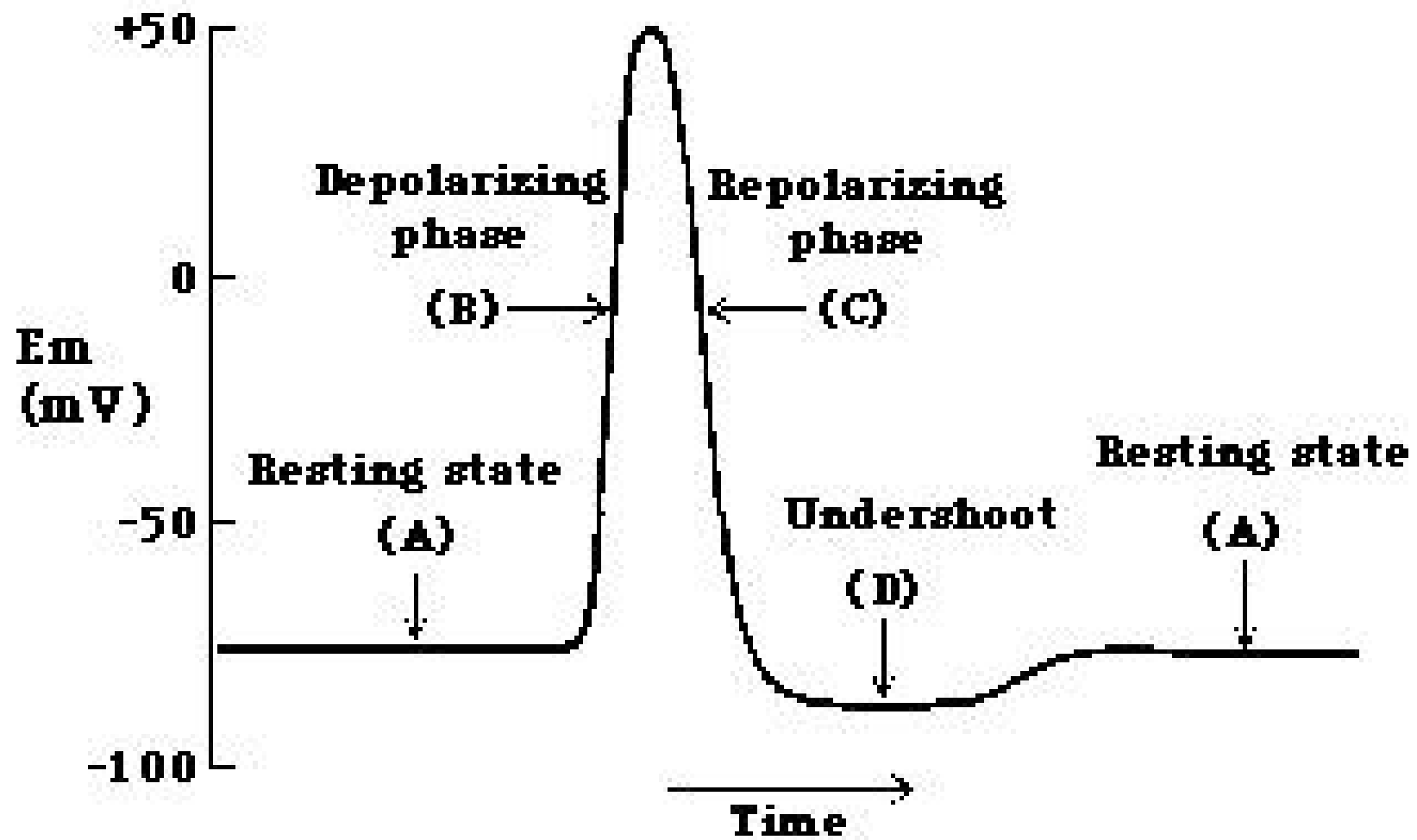
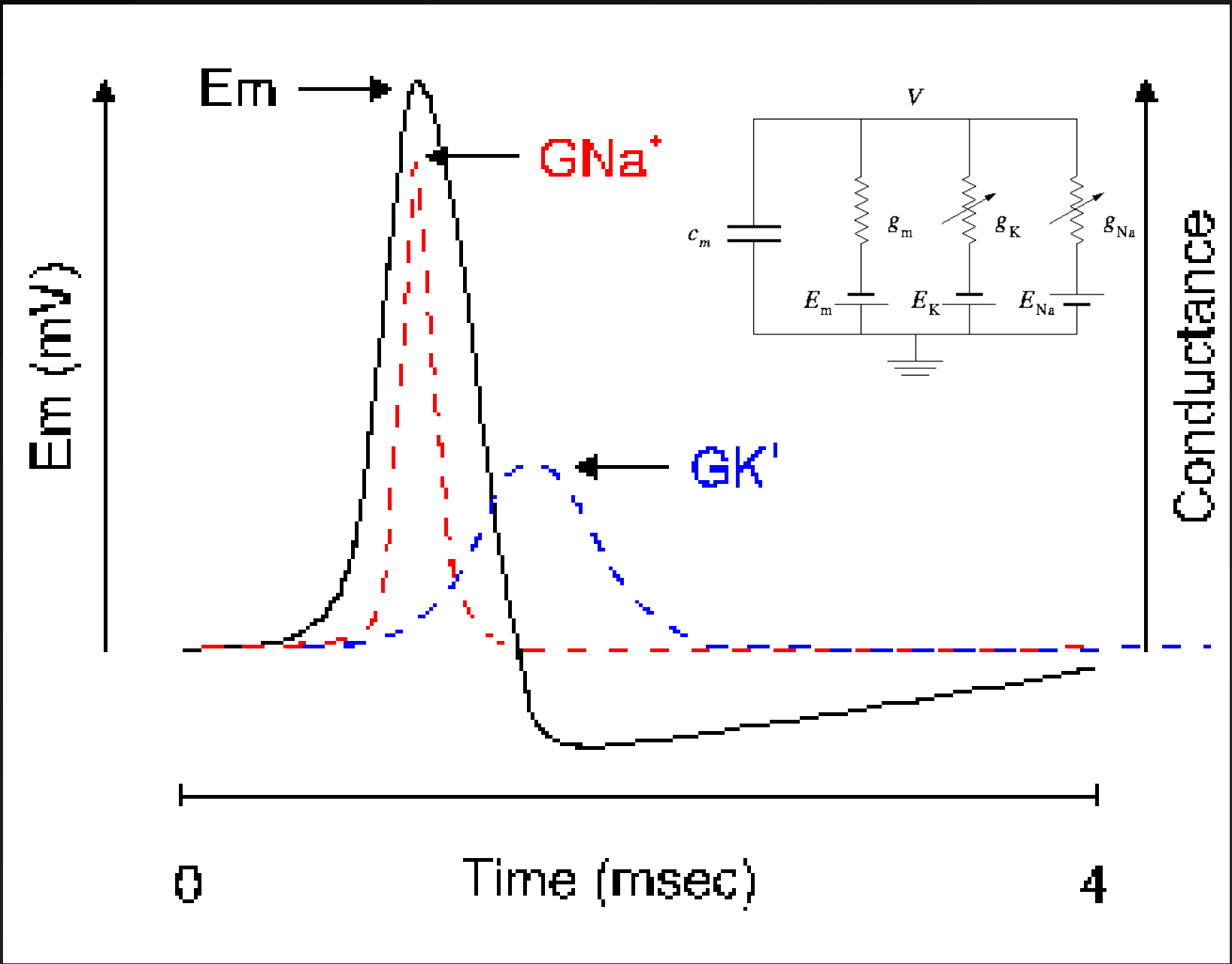

Fig. 2-3. Intra- and extracellular distribution of the ions. On both sides of the membrane, the different ions are indicated by *circles of different diameter*, proportional in each case to the diameter of the (hydrated) ion. A^- designates the large intracellular protein anions. The passages through the membrane, the "pores," are just large enough to permit the K^+ ions to diffuse through.

V inside







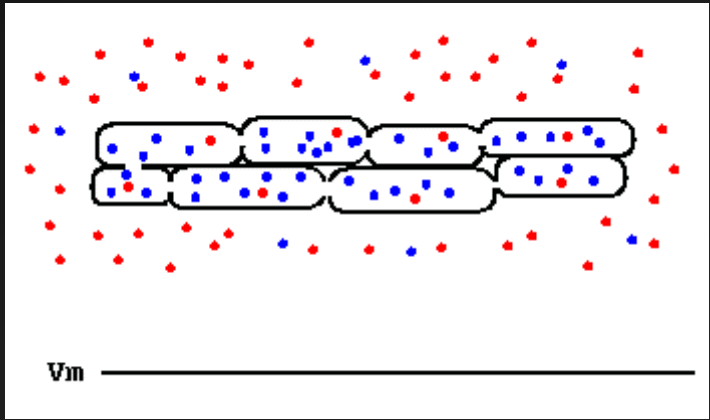

Synaptic Transmission

- Not an all-or-none phenomenon
- Synaptic gap or cleft at the synaptic junction
- Single axon splits near end--**terminal arborization**
- As action potential arrives
 - Synaptic vesicles migrate to cell membrane fuse and release
 - Neurotransmitters diffuse across the synaptic cleft
 - combine with **post-synaptic receptors**
 - When neurotransmitter binds to a receptor on the post-synaptic cell, a slow electrical potential (**post-synaptic potential**) is generated:
 - 5 to 20 mV at peak amplitude
 - 20-150 msec in duration (50 to 6 Hz)

Presynaptic Axon Terminal

Synaptic Vesicles

Synaptic Cleft

Neurotransmitter

**EXCITATORY-
receiving neuron
more likely to fire!**

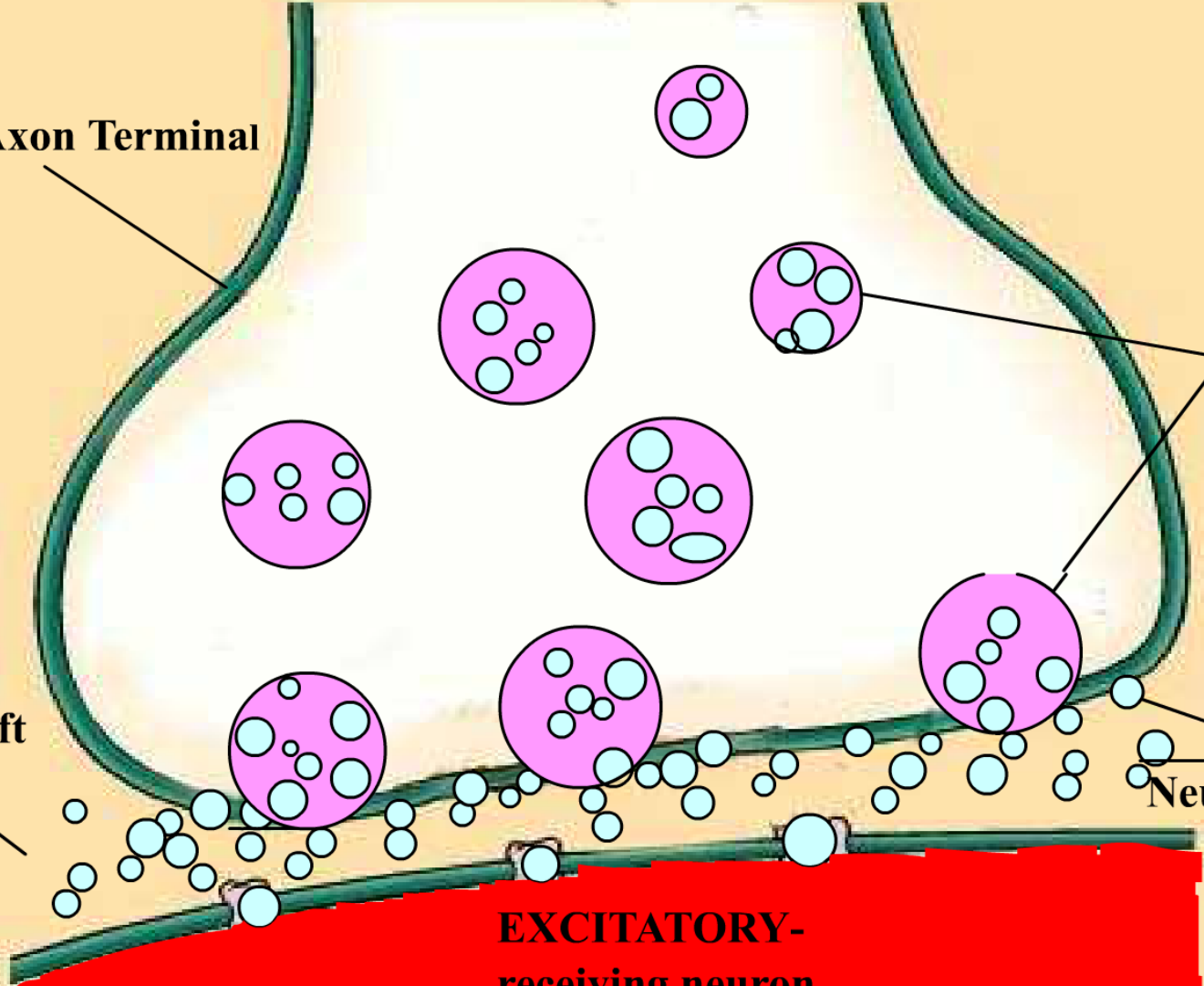

Synaptic Transmission

- Post-synaptic potentials (PSP's);
 - Excitatory
 - Inhibitory
 - Interaction
- **Summation/Integration**
 - temporal
 - spatial
 - **decremental conduction** on dendrites and soma
 - axon hillock is critical area at which threshold must be reached
- After release of neurotransmitter,
 - reuptake
 - degradation
- **Functional Synaptic Units**

[Jump to Next](#)

Synaptic Transmission

1. Within the axons of the neuron are neurotransmitters, which are held in storage-like vesicles until they are released when the neuron is stimulated.

2. The small space between the axon terminal and the dendrite of the next axon is called the synapse. An action potential stimulates the release of neurotransmitters across the synapse.

3. The neurotransmitter binds itself to the receptor sites on dendrites of the next neuron, causing a change in potential.

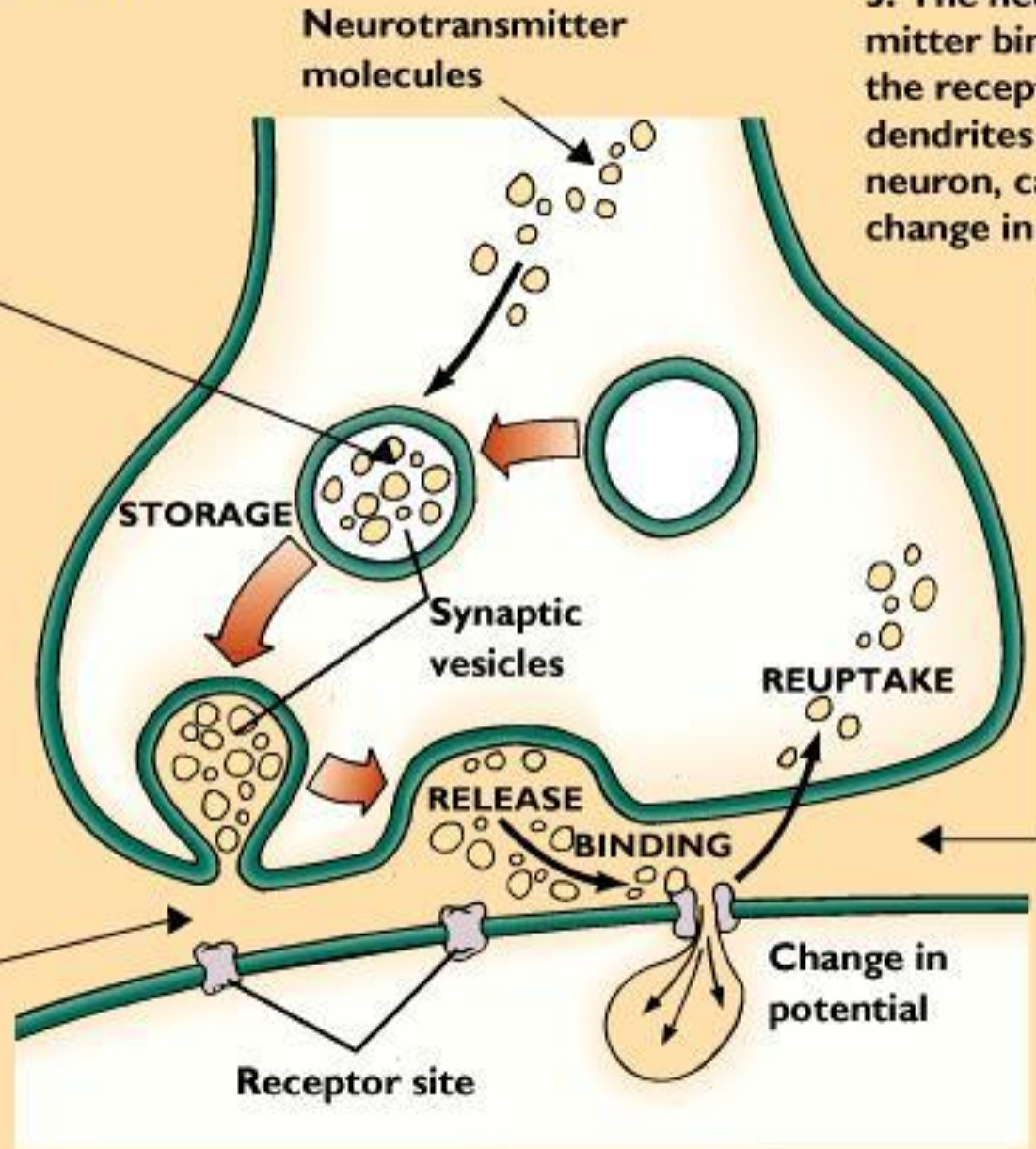

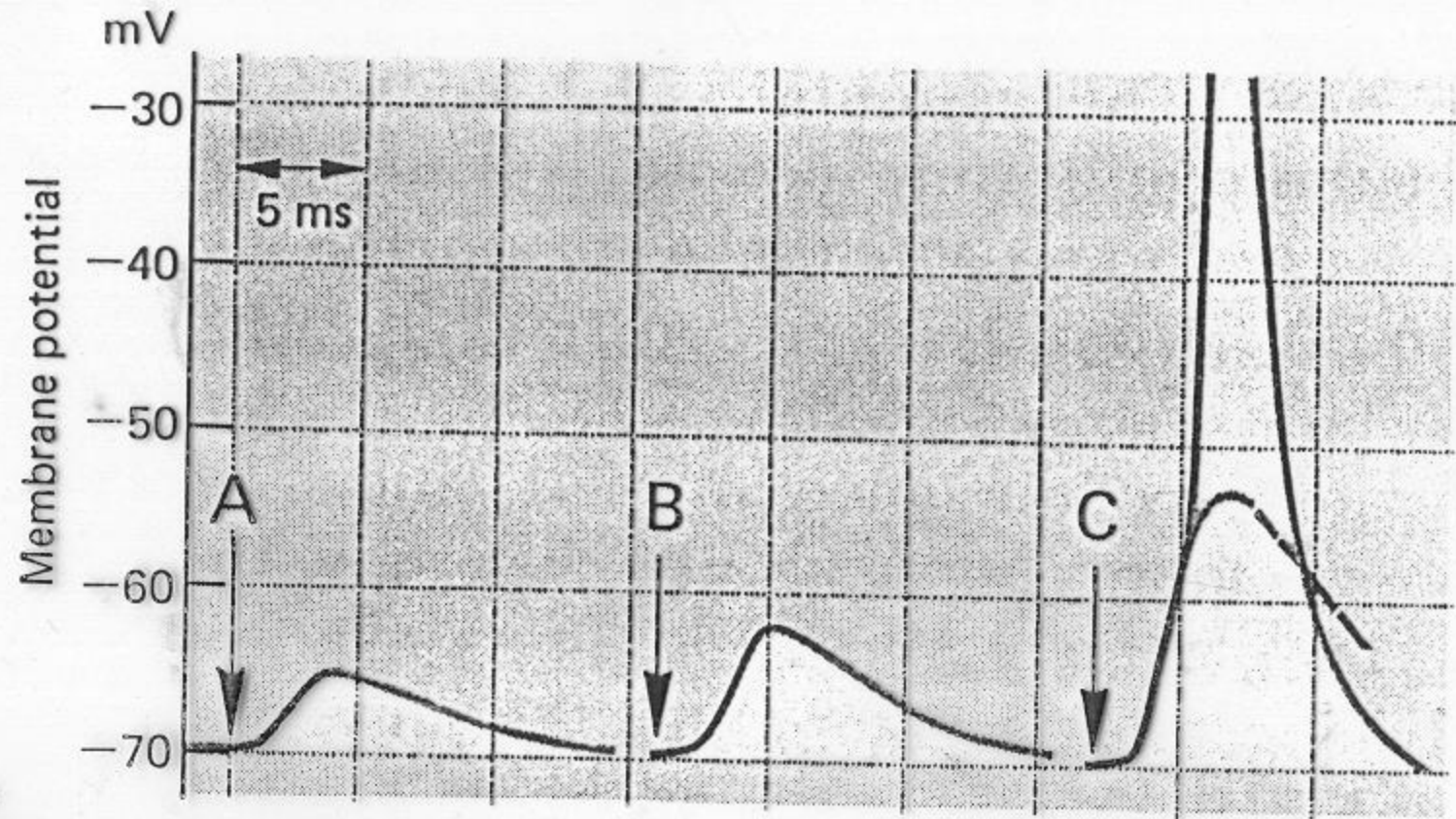
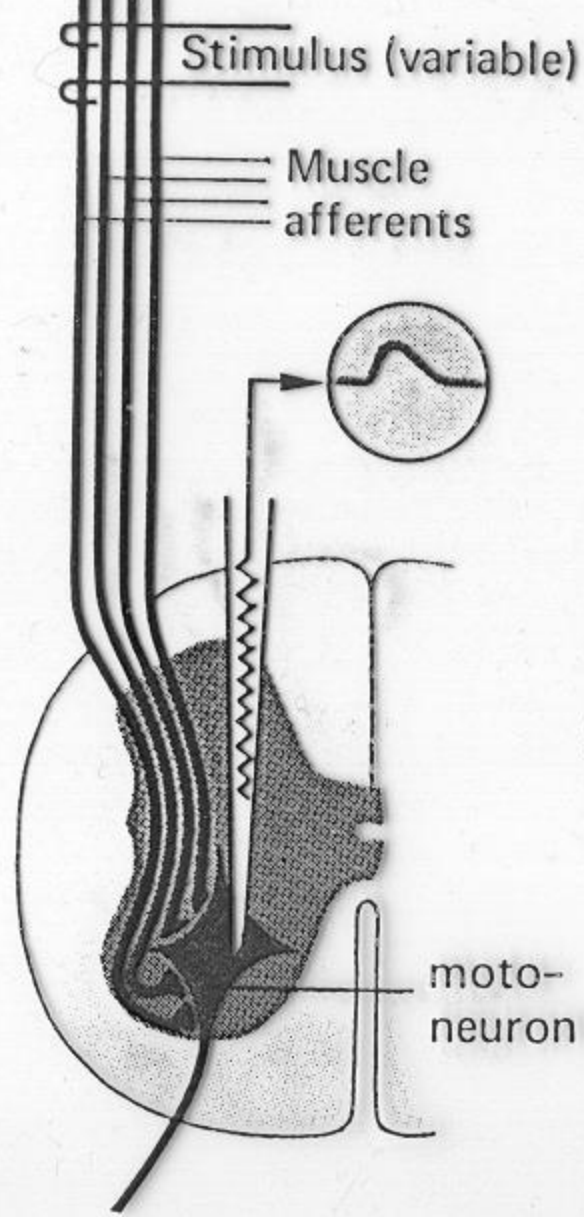

Fig. 3-10. Excitatory postsynaptic potentials, recorded intracellularly from a motoneuron. Afferents in the peripheral nerve from the associated muscle are stimulated electrically at intervals of 100 ms.

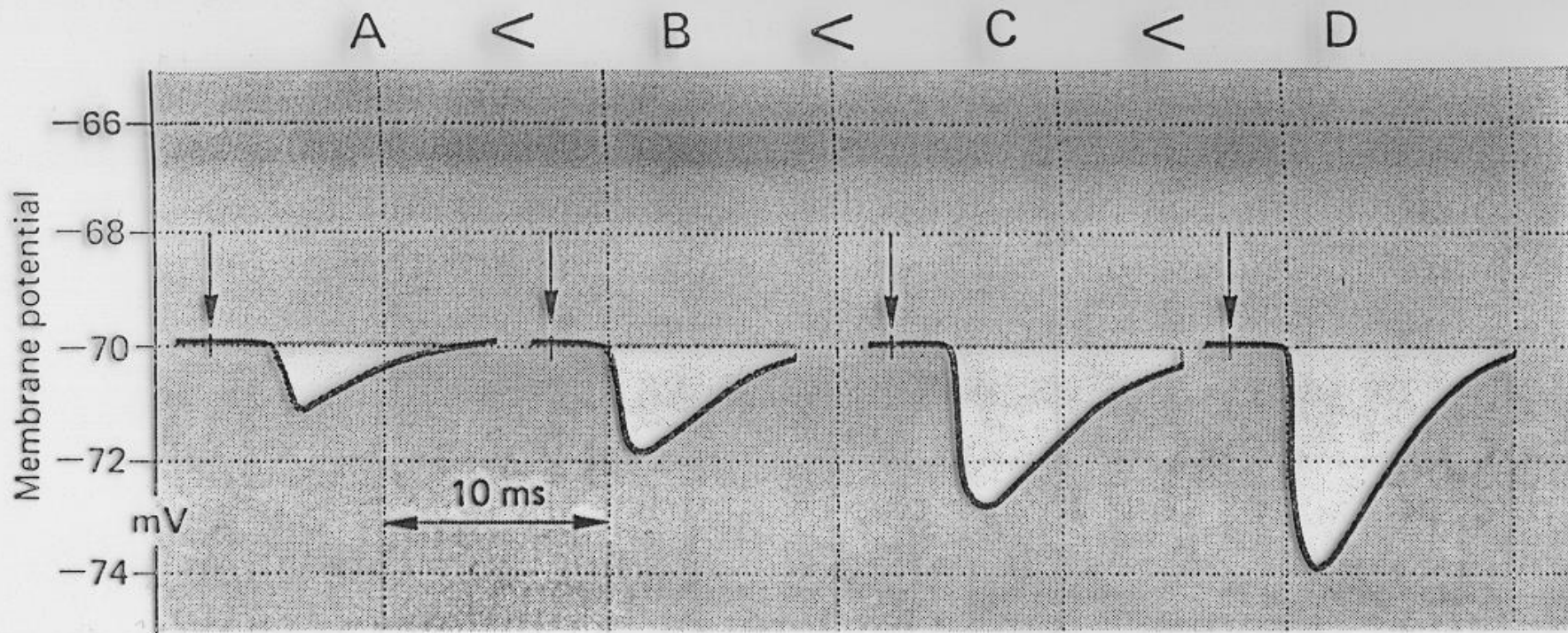

Fig. 3-11. Inhibitory postsynaptic potentials. Experimental arrangement as in Fig. 3-10, except that here an antagonist nerve is stimulated.

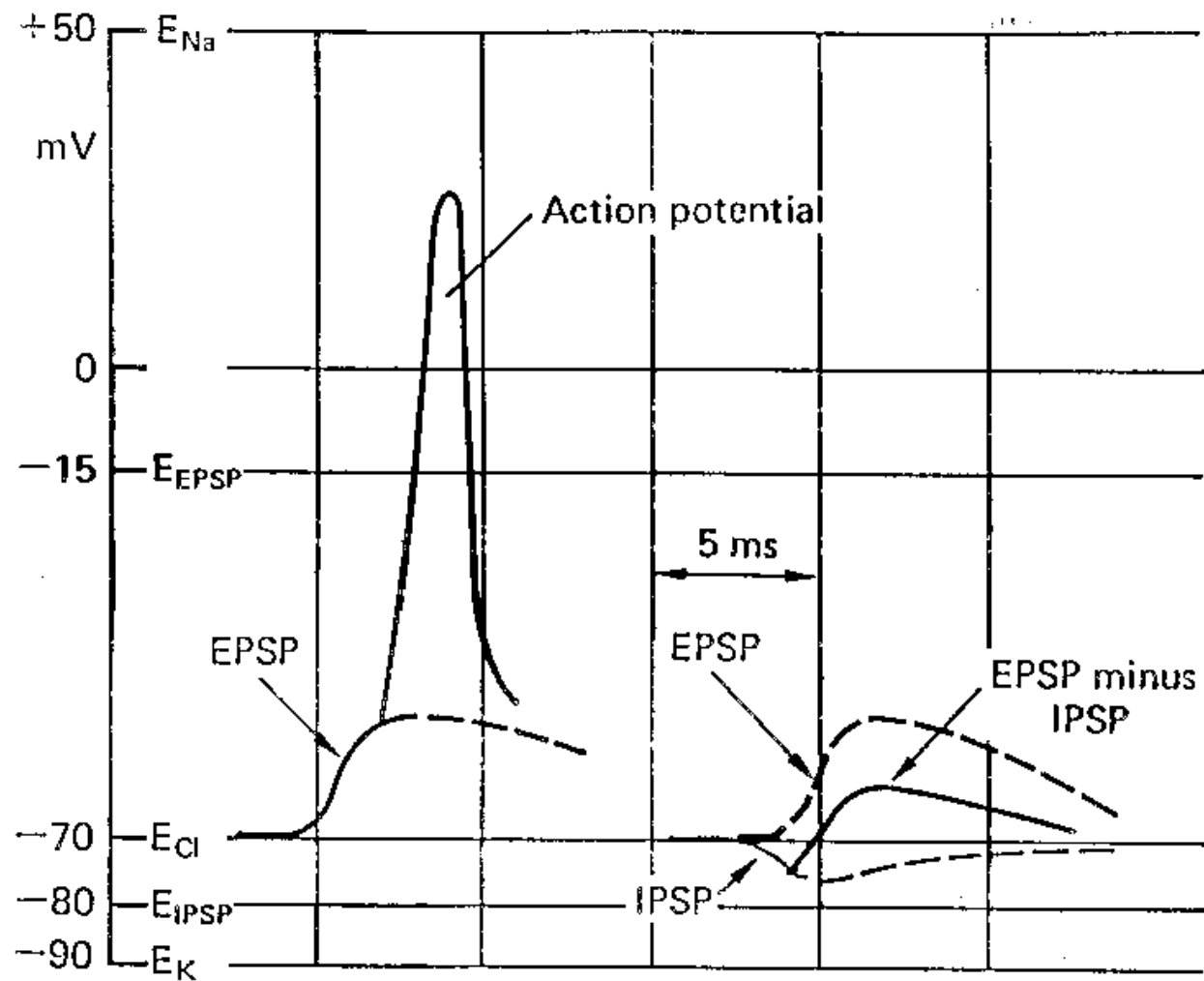
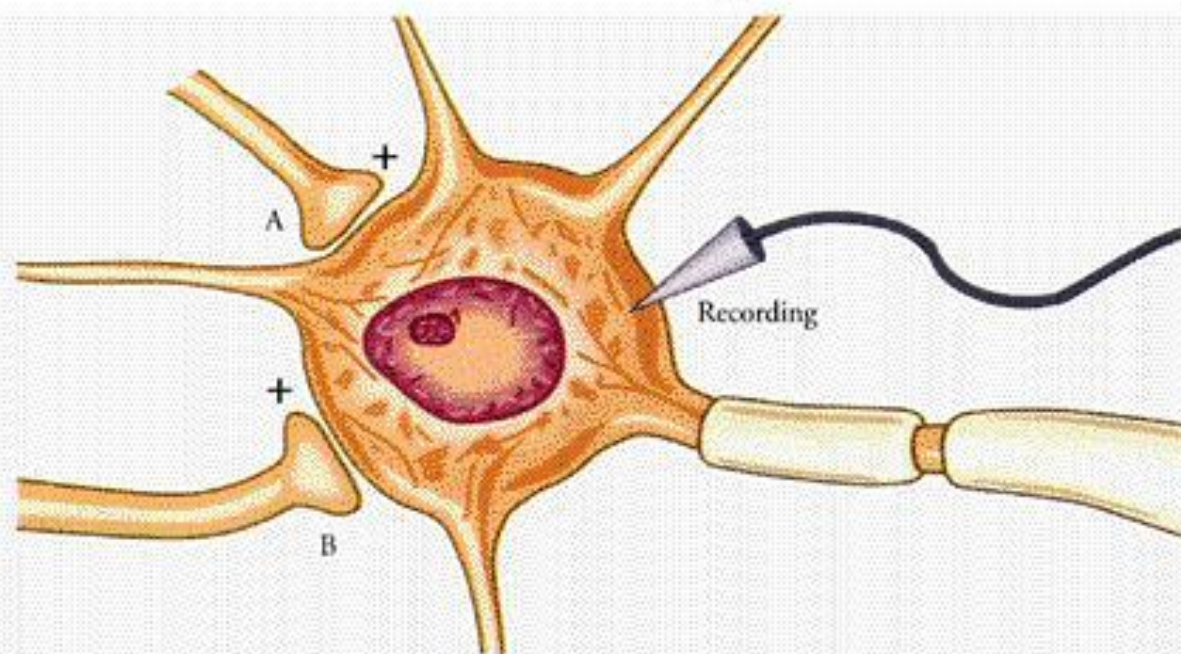
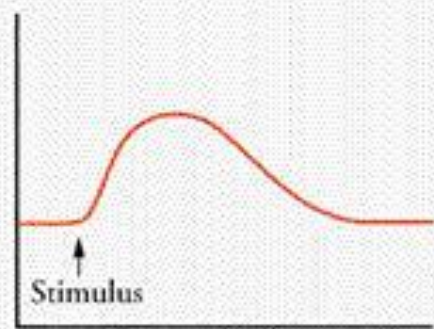

Fig. 3-14. The effect of an IPSP on the action potential; experimental arrangement as in Fig. 3-13. The homonymous nerve is stimulated strongly enough to produce a supra-threshold EPSP (*left*). On the *right*, the antagonist nerve is stimulated about 3 ms before the homonymous nerve. The equilibrium potentials of Na^+ , K^+ , Cl^- , EPSP, and IPSP are shown.

Spatial Summation. Figure 5.11



Spatial summation



A only

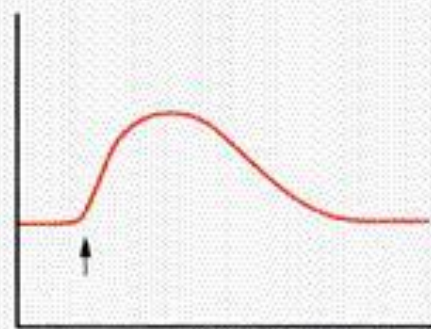

B only

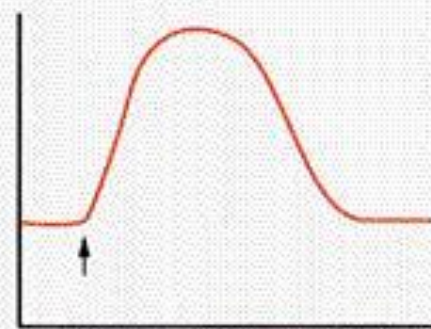

A + B

Temporal Summation. Figure 5.11

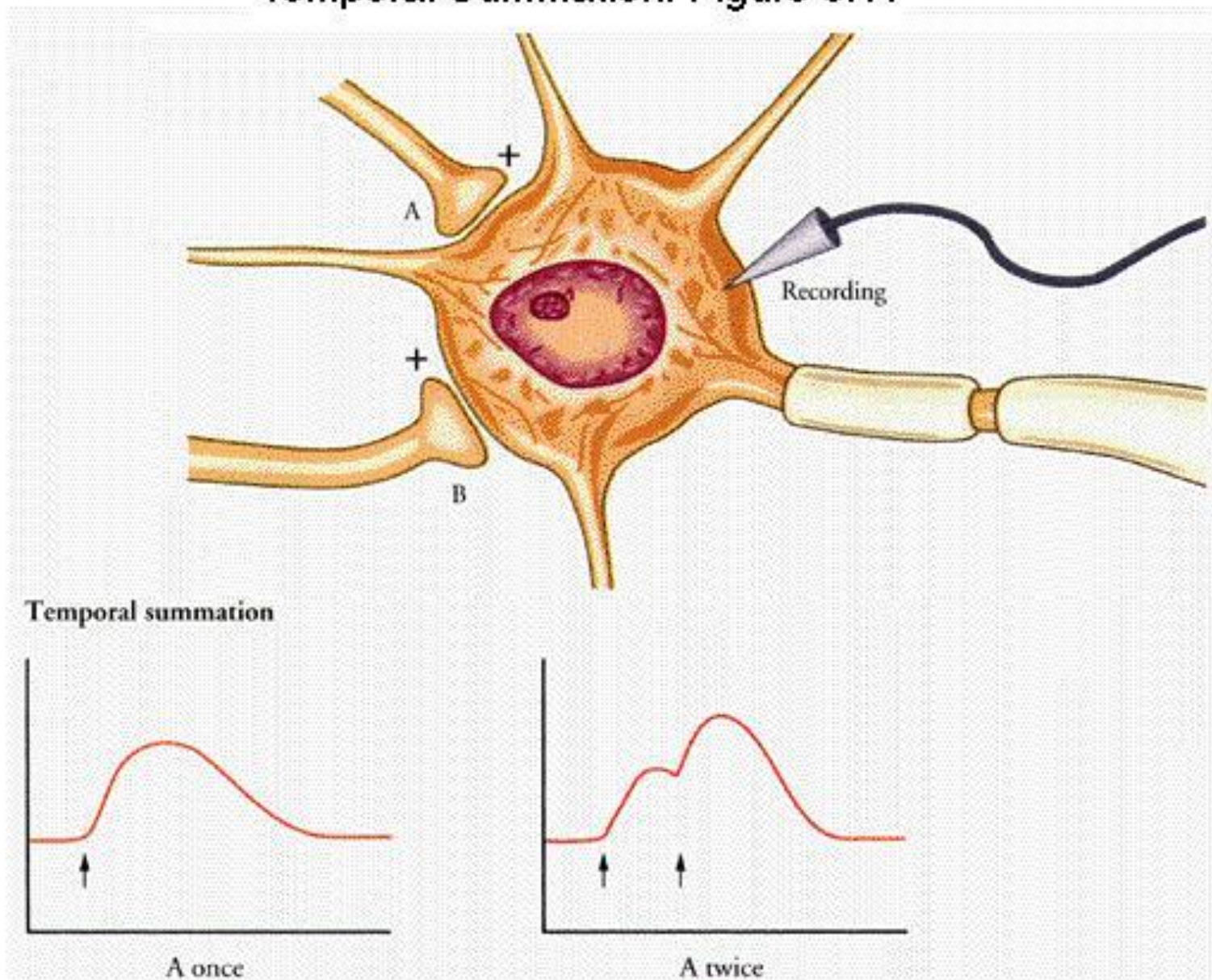

Part III: Basic Neuroanatomy

*If the human brain were so
simple that we could
understand it,
we would be so simple that we
couldn't.*

V. Organization of the nervous system

A. Central nervous system

1. Brain

2. Spinal cord

Human Nervous System

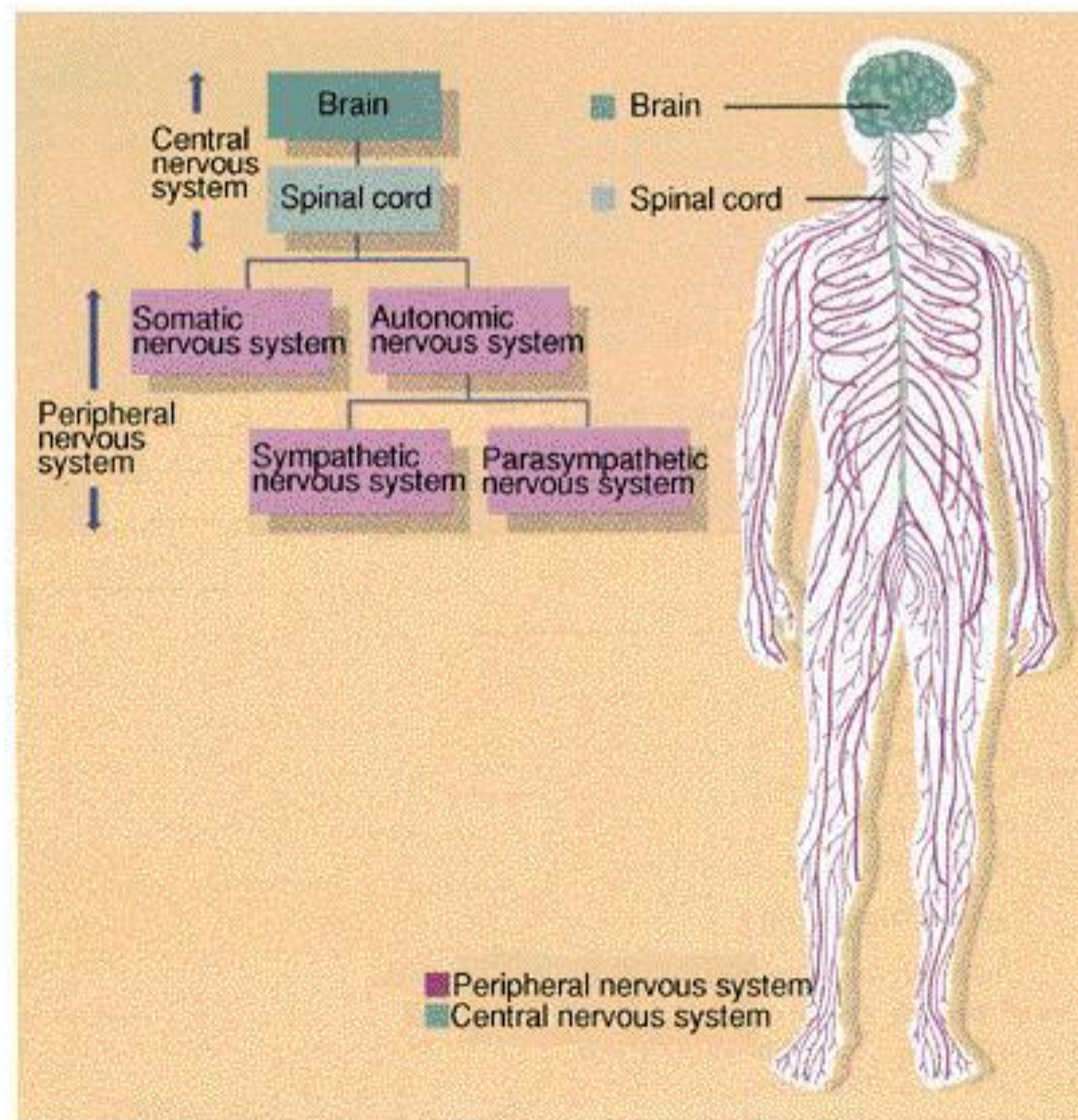

V. Organization of the nervous system

B. Peripheral nervous system

1. Somatic system

2. Autonomic system; two branches
work in generally antagonistic
fashion

Somatic System

- Descending motor tracts within spinal cord synapse at approximate level of exit
- Post-synaptic neuron directly innervates target
- 2-neuron system

Autonomic System

- Descending motor tracts within spinal cord synapse not necessarily at level of exit
- After exit, synapse again before innervating target
- 3-neuron system

Autonomic Nervous System

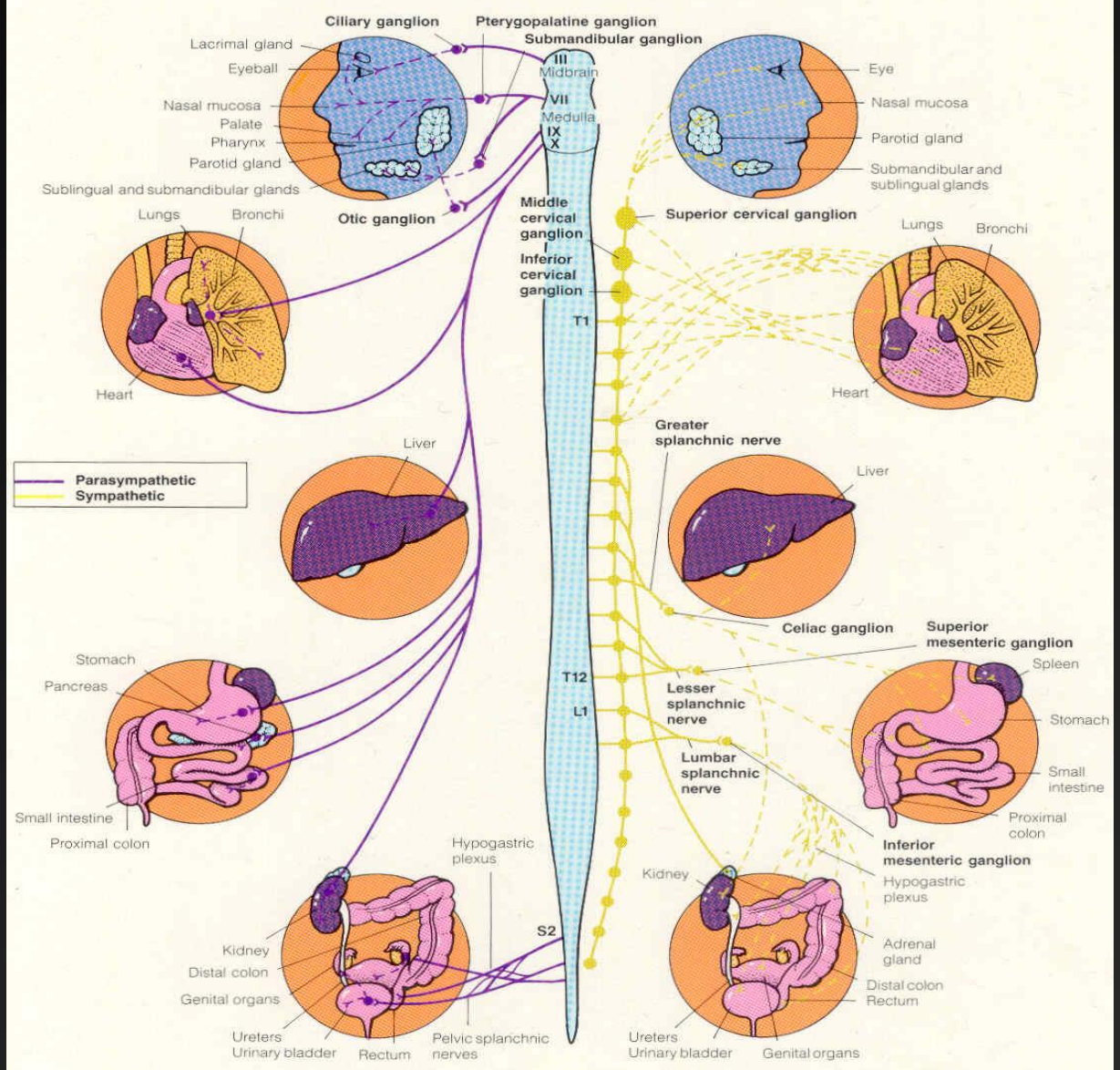

V. Organization of the nervous system

B. Peripheral nervous system

2. Autonomic system

a. Sympathetic nervous system

1. tends to have system-wide effects
2. flight or flight; activity

b. Parasympathetic nervous system

1. tends to affect one organ at a time
2. quiescent processes--digestion, protects and conserves energy

Sympathetic

- Prepares body for action
- Catabolic processes that require energy expenditure

- After synapse within grey-matter of spinal cord, the post-synaptic (pre-ganglionic) neurons exit in thoracic or lumbar regions

- *Thoracolumbar system*
- pre-ganglionic neurons travel to sympathetic chain (series of connected sympathetic ganglia ("*swelling or knot*", chain of neurons))
- post-ganglionic neurons generally travel a long distance to target organ

Parasympathetic

- Restores and maintains body resources
- Anabolic processes that increase the body's supply of stored energy

- After synapse within grey-matter of spinal cord, the post-synaptic (pre-ganglionic) neurons exit in cranial (especially cranial nerve #10, Vagus) or sacral regions

- *Craniosacral system*
- pre-ganglionic neurons travel some distance before synapsing in the parasympathetic ganglia located in the immediate vicinity of the target organ
- post-ganglionic neurons are therefore typically quite short

Sympathetic

Pharmacologically,

- All synapses within the sympathetic ganglia are acetylcholinergic
- Terminal buttons on target organs are noradrenergic (except sweat glands: acetylcholinergic)

- Quick diffuse action of system due to the sympathetic ganglionic chain prepares organism for *fight-or-flight*; in synchrony, many systems activate
- dilation of bronchioles
- dilation of pupils (the better to see you with my dear)
- constriction of blood vessels to skin and gastrointestinal system
- inhibition of gastrointestinal system
- increased BP, stroke volume, cardiac output
- increased sweating

Parasympathetic

Pharmacologically,

- All synapses acetylcholinergic: both pre- and post-ganglionic neurons

- Slower and more specific action of this system works to restore and maintain bodily resources; only changes that are necessary generally occur (not all systems in synchrony)
- decreased heart rate, blood pressure
- constriction of pupils and bronchioles
- increases in digestive functions

VI. The common household brain

- Commentary
- More commentary

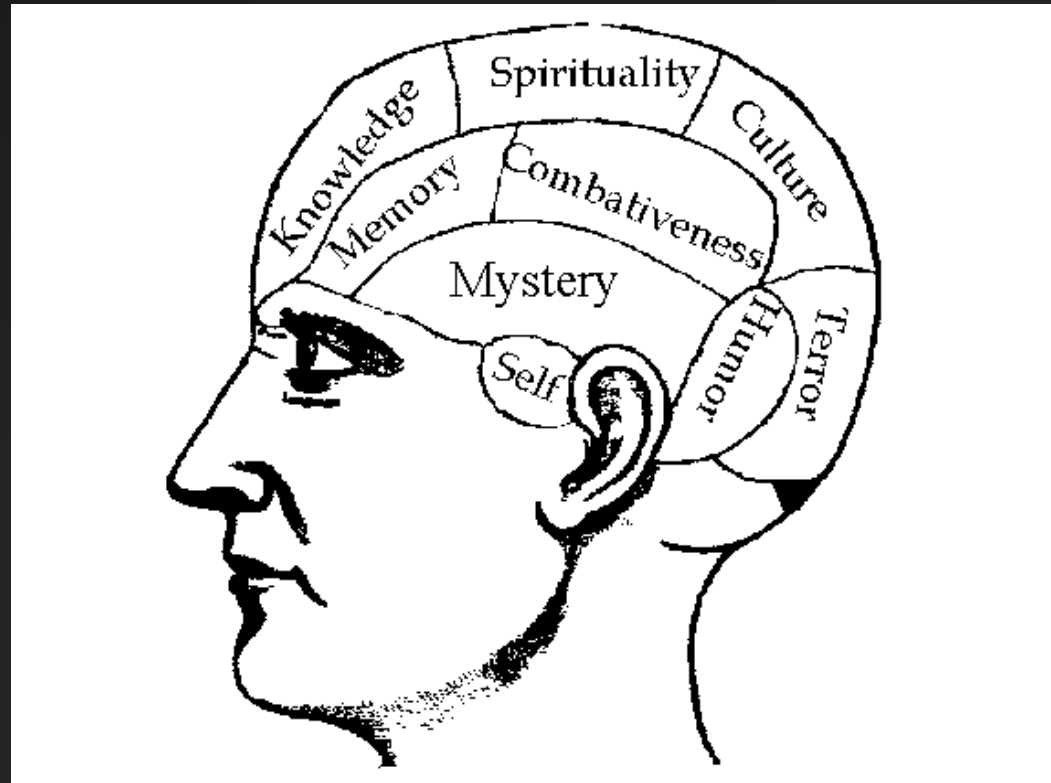

Brain's Main Structures

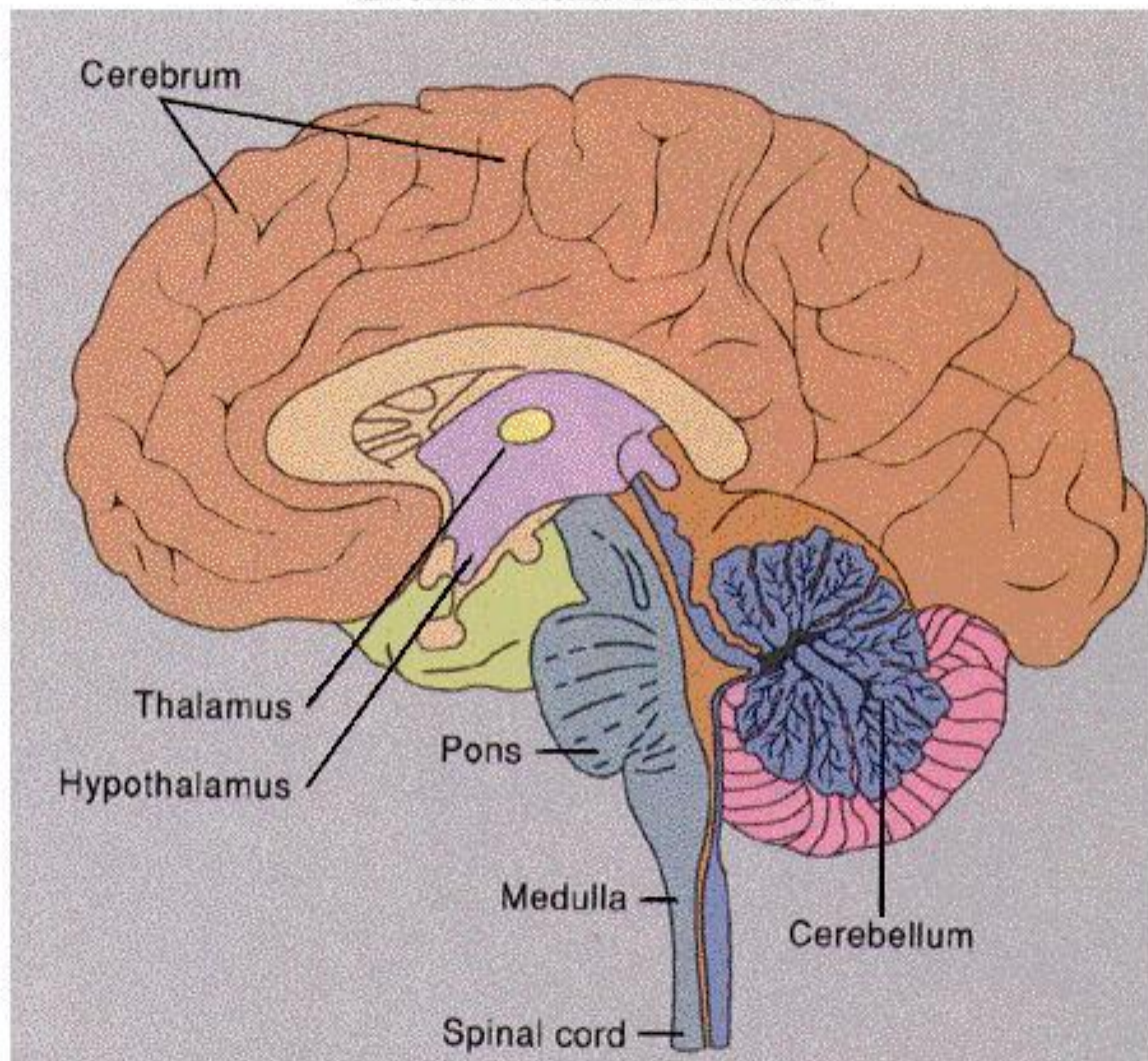

VI. The common household brain

A. Overview of brain

1. The primitive central core
2. Limbic system, or the “Inner Lizard”
3. Cerebrum (AKA cerebral hemispheres)
 - a. Ontogeny
 - b. Phylogeny
 - c. Ontogeny recapitulates phylogeny
4. These three layers are interconnected extensively; do not function independently

Next

The Human Brain: Major Areas

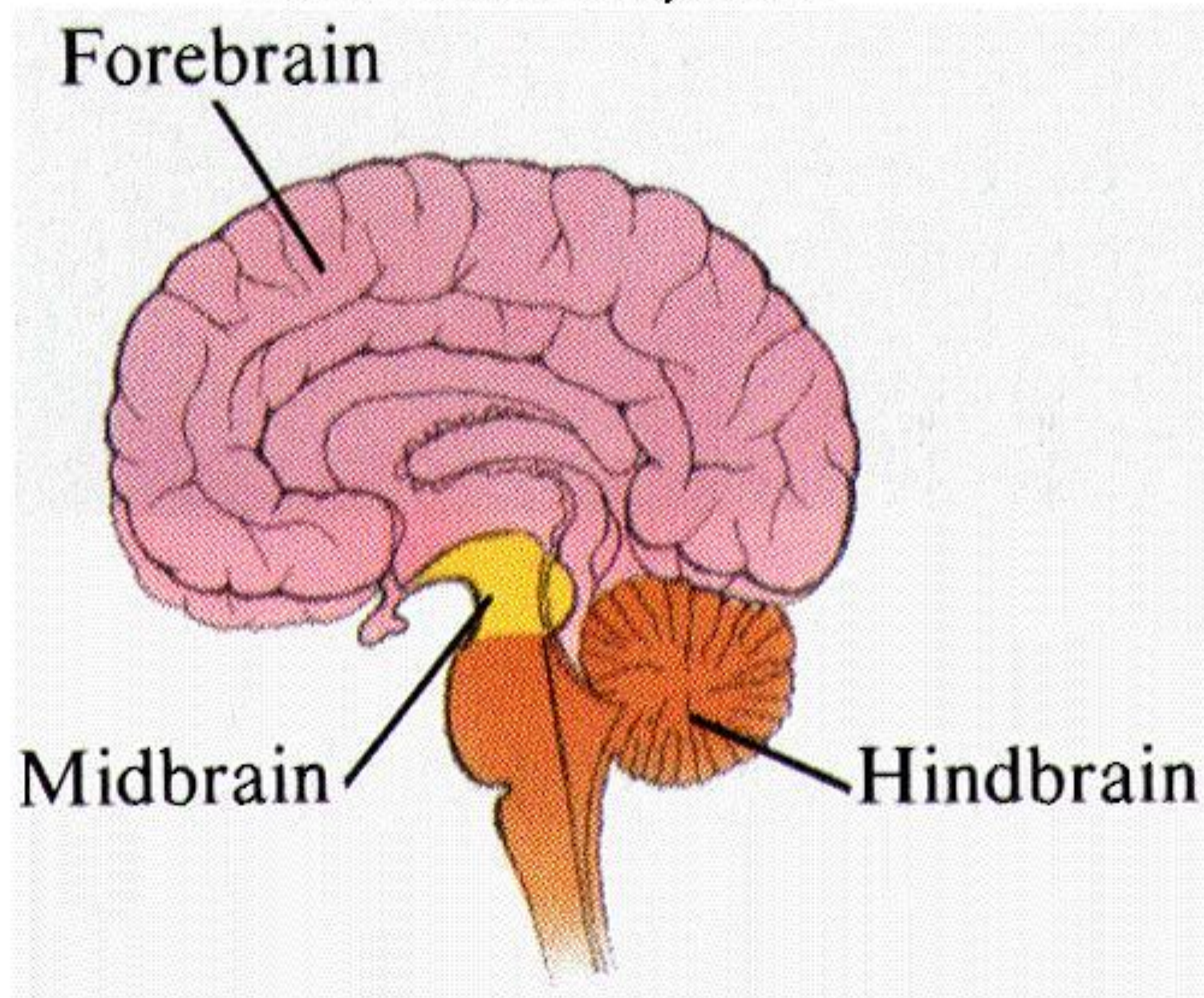

Principal Structures of the Limbic System

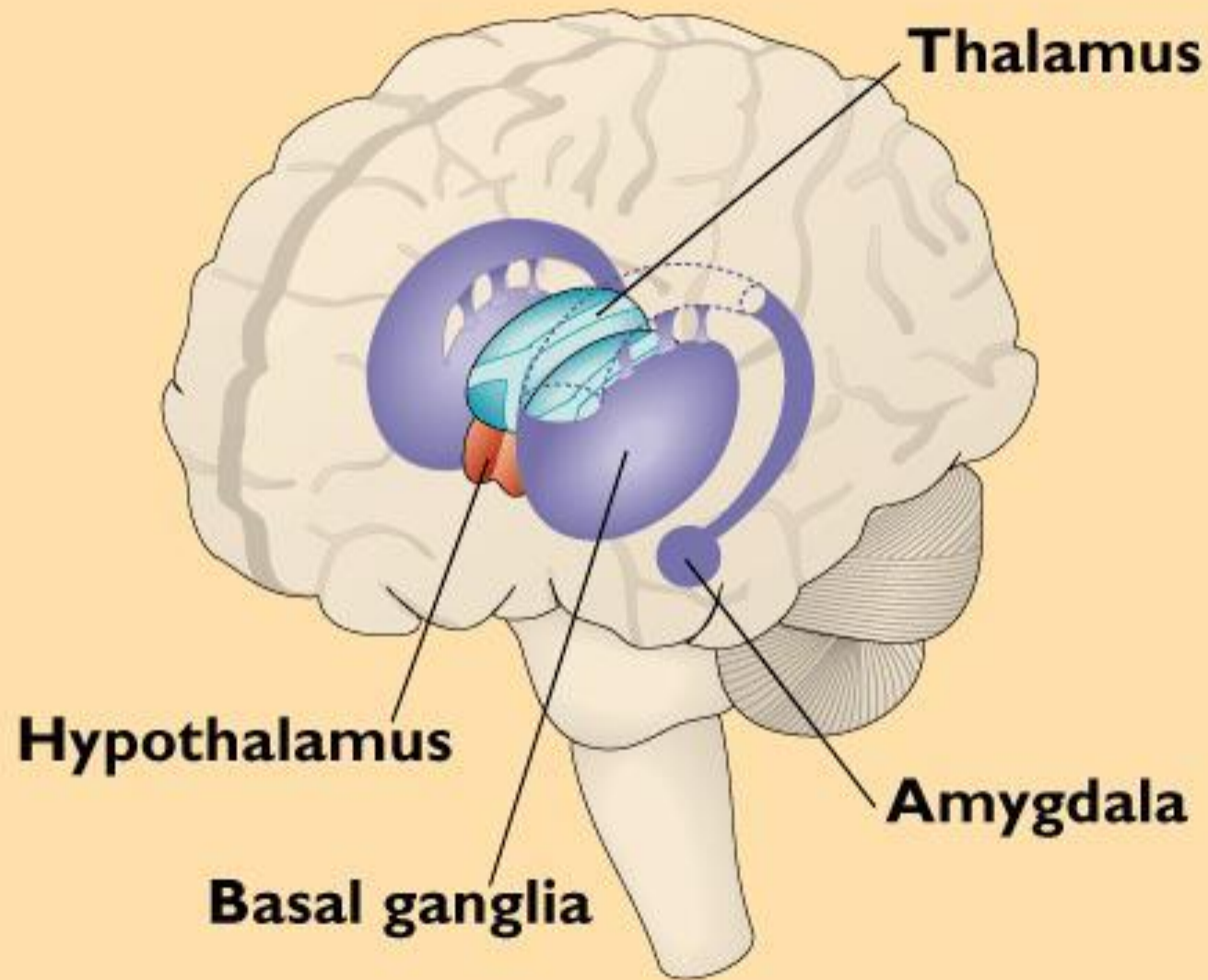



3 weeks



4 weeks



5 weeks



7 weeks



11 weeks

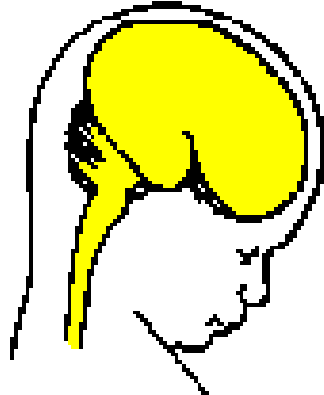

4 months

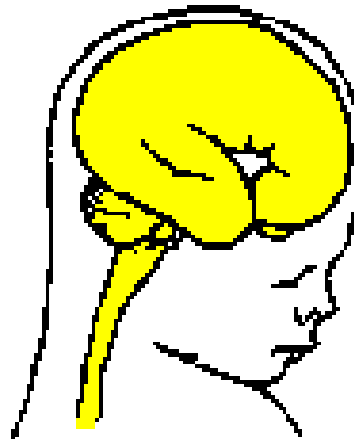

6 months



8 months



Newborn

The Evolution of the Cerebrum*

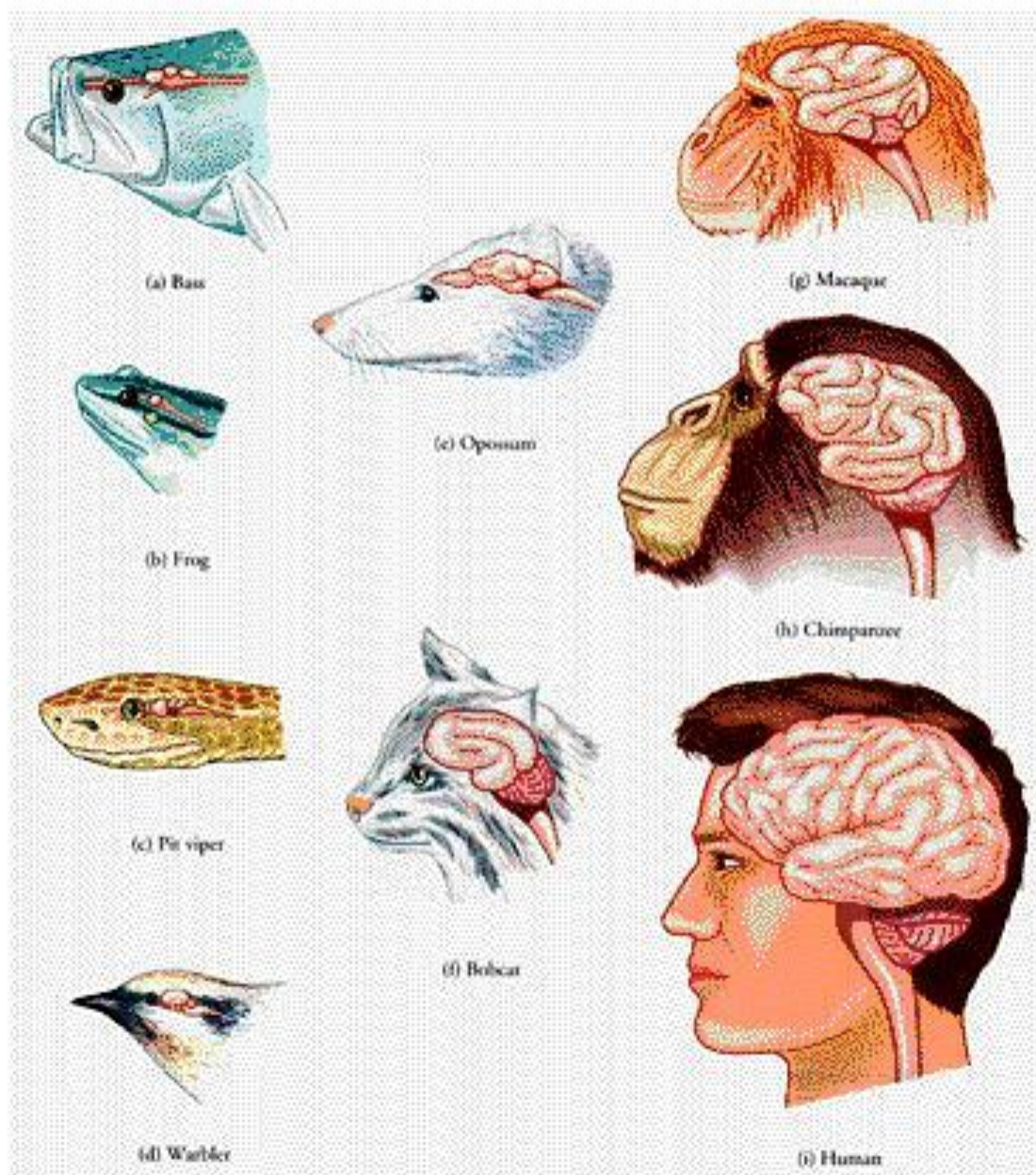

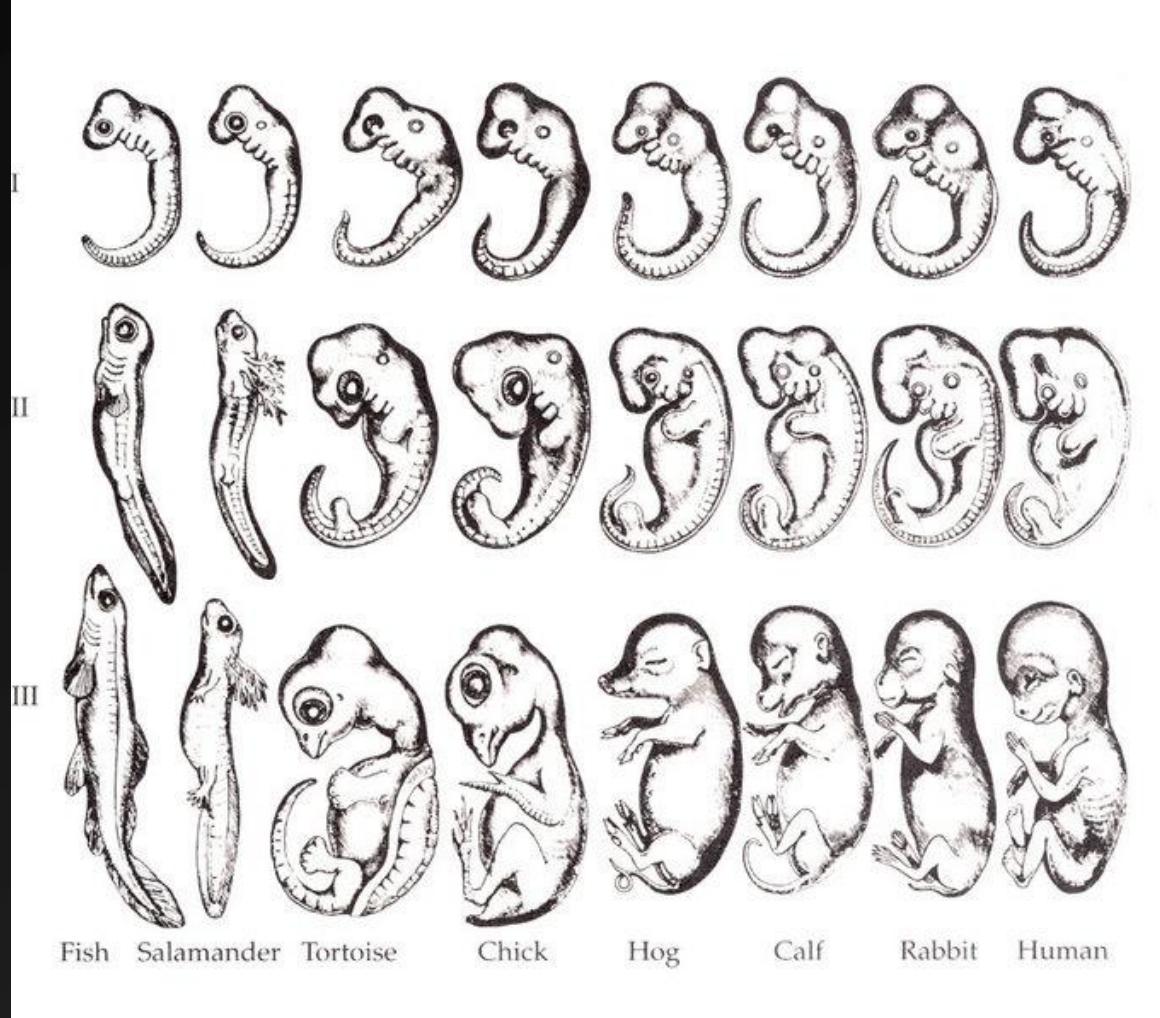

"... this history of the embryo (ontogeny) must be completed by a second, equally valuable, and closely connected branch of thought - the history of race (phylogeny). Both of these branches of evolutionary science, are, in my opinion, in the closest causal connection; this arises from the reciprocal action of the laws of heredity and adaptation... 'ontogenesis is a brief and rapid recapitulation of phylogenesis, determined by the physiological functions of heredity (generation) and adaptation (maintenance).'"

Haeckel, E. 1899. *Riddle of the Universe at the Close of the Nineteenth Century*.

Directions please!

- lateral--side; medial--middle
- anterior--front; posterior/dorsal--back
- rostral--towards the nose; caudal--towards the tail
- ipsilateral--same; contralateral--opposite
- proximal--toward the soma; distal--away from the soma
- efferent--output/motor; afferent--receiving/sensory

B. Brain Specifics

1. Primitive central core

a. Cerebellum

1. "little brain" located to rear of brain stem
2. involved in smooth coordination of movements
3. learning of complex motor activities (e.g., piano, skiing)

B. Brain Specifics

1. Primitive central core

b. Thalamus & Hypothalamus: located just above the brain stem & tucked inside the cerebral hemispheres

1. Thalamus is a relay station for sensory information

a. "Gateway to the cortex"

b. coming from spinal cord to cortex

c. taste touch hearing vision -- olfaction is exception

2. Hypothalamus

a. literally = "under thalamus" ; much smaller, but very important

b. 4 F's:

Structures of the Brain

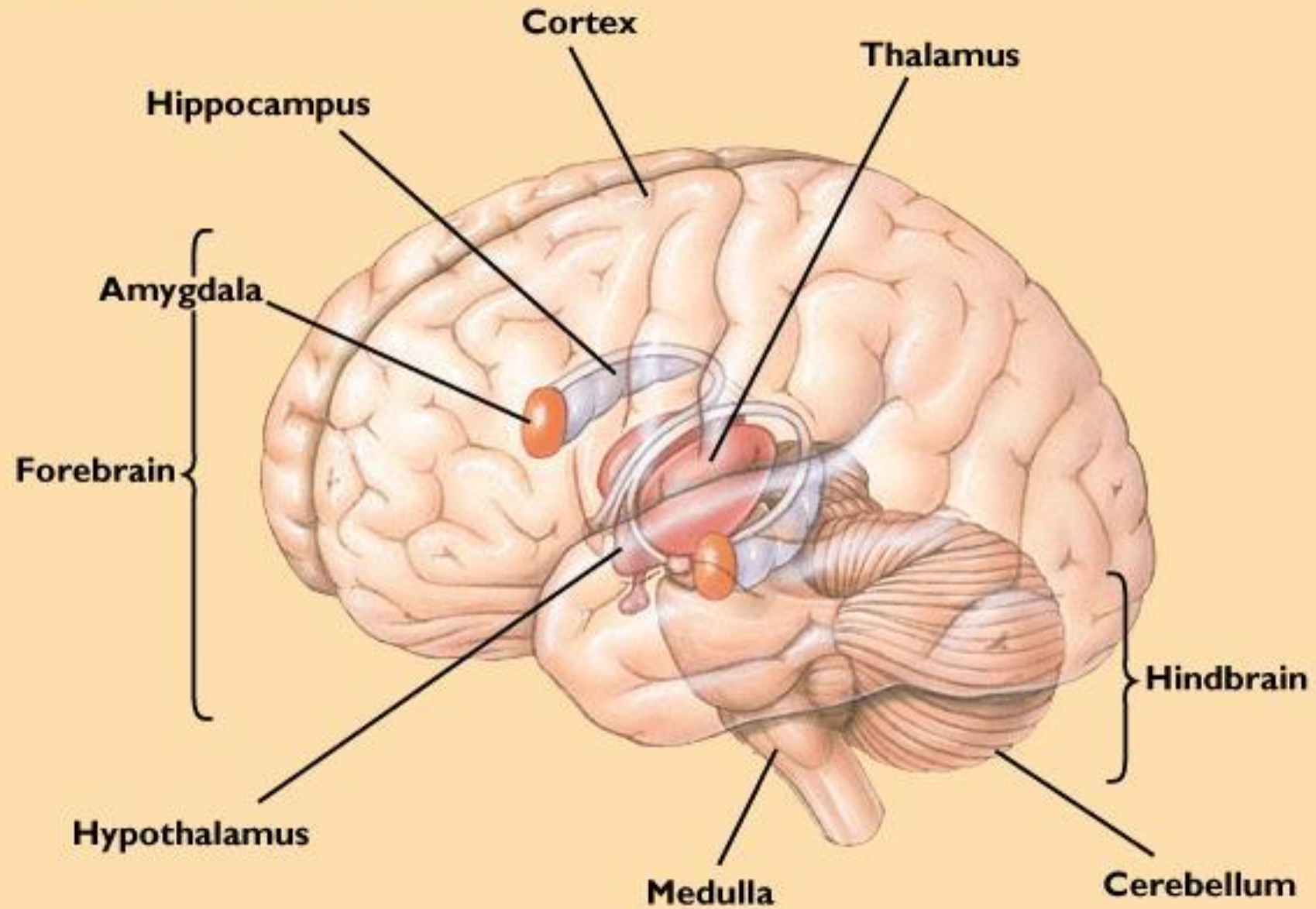

Forebrain

- Cerebral cortex
- Corpus callosum
- Thalamus
- Hypothalamus

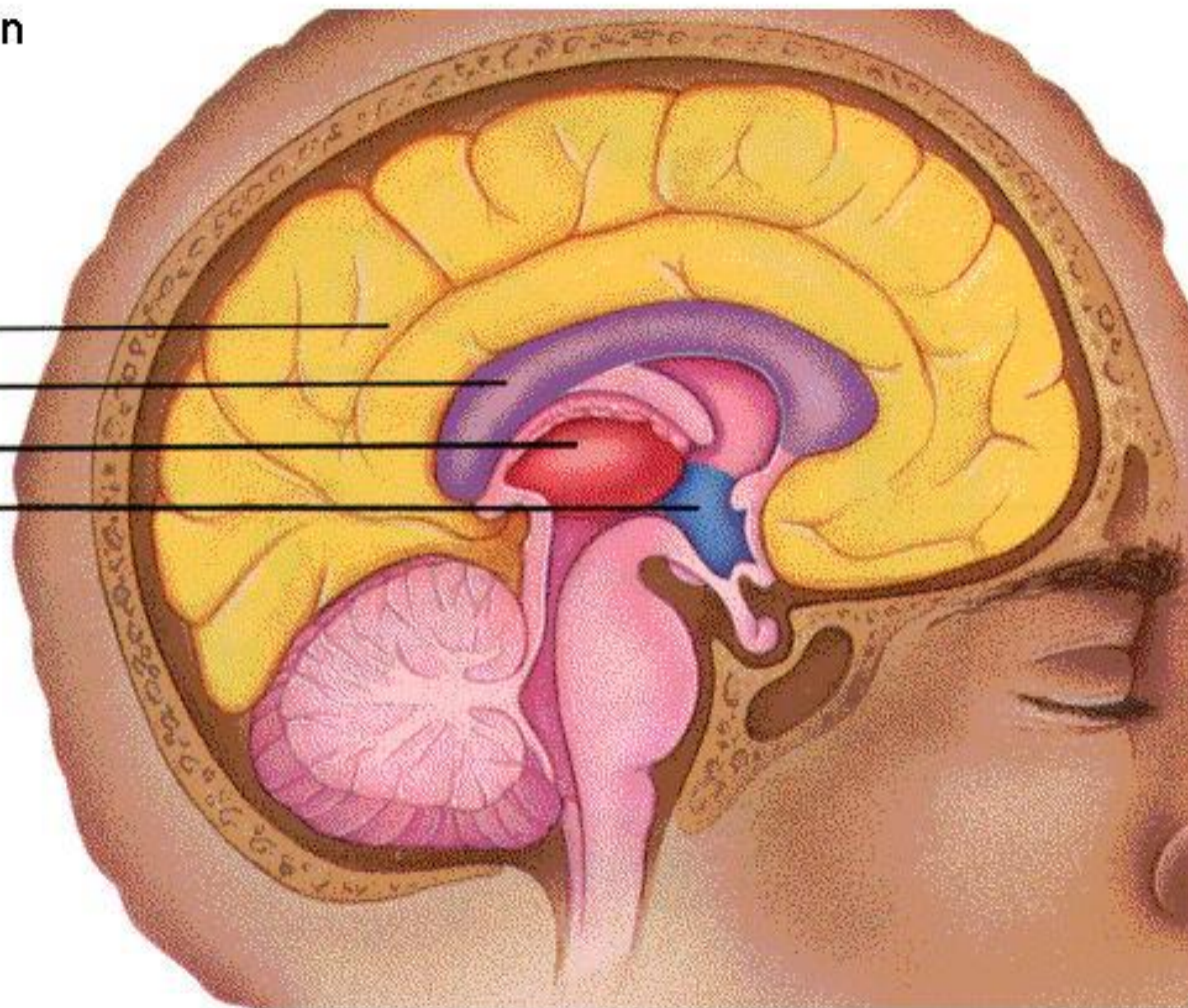

B. Brain Specifics

1. Primitive central core

c. Reticular system

a. diffuse from brainstem to thalamus

b. 3 A's, arousal, awareness, attention

B. Brain Specifics

2. Limbic system

- a. a group of structures lying along the innermost edge of the cerebral hemispheres
- b. involved in instinctual behaviors in lower animals (caring for young, mating, fleeing from attackers, fleeing from prey)
- c. involved in memory and emotion in humans
- d. Especially important structures within the Limbic system:
 - i.. Hippocampus
 - ii. Amygdala

Brain's Main Structures

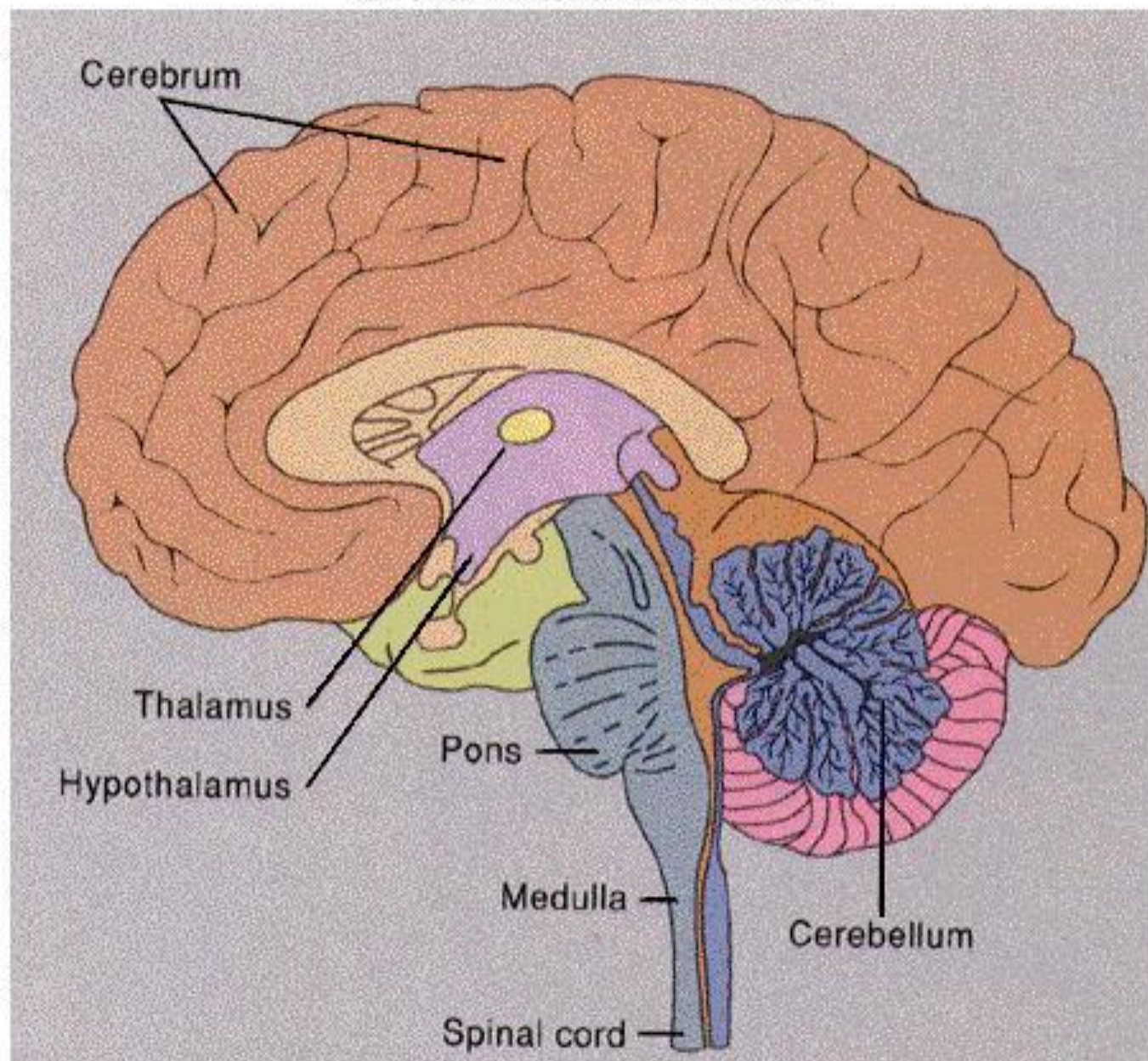

The common household brain

- 3. The cerebral hemispheres
 - a. Grey matter vs white matter

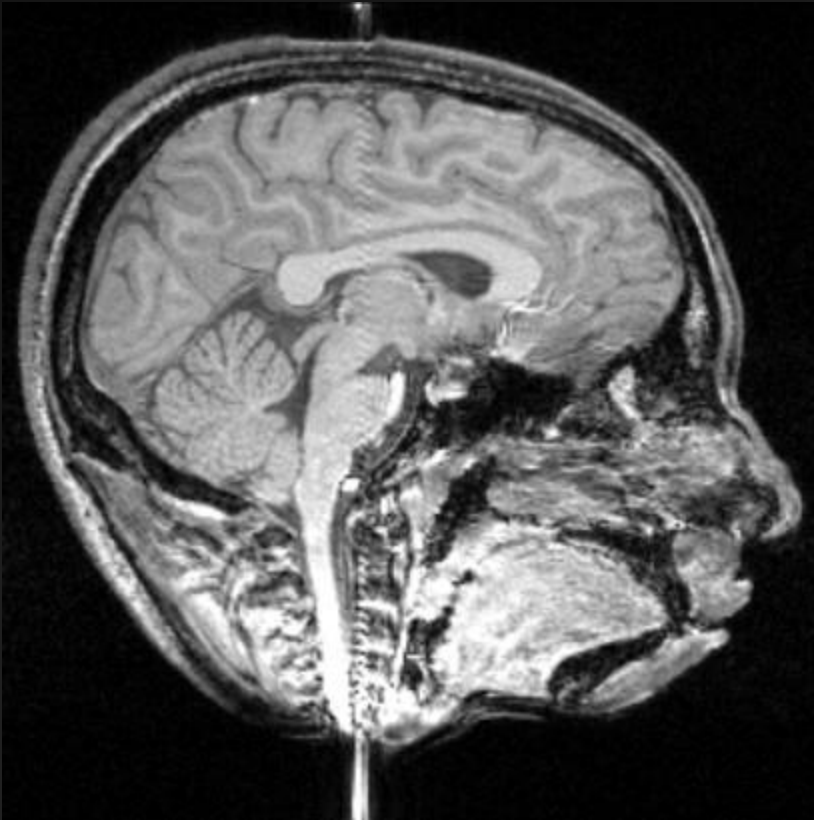

Four Lobes of the Cerebral Cortex

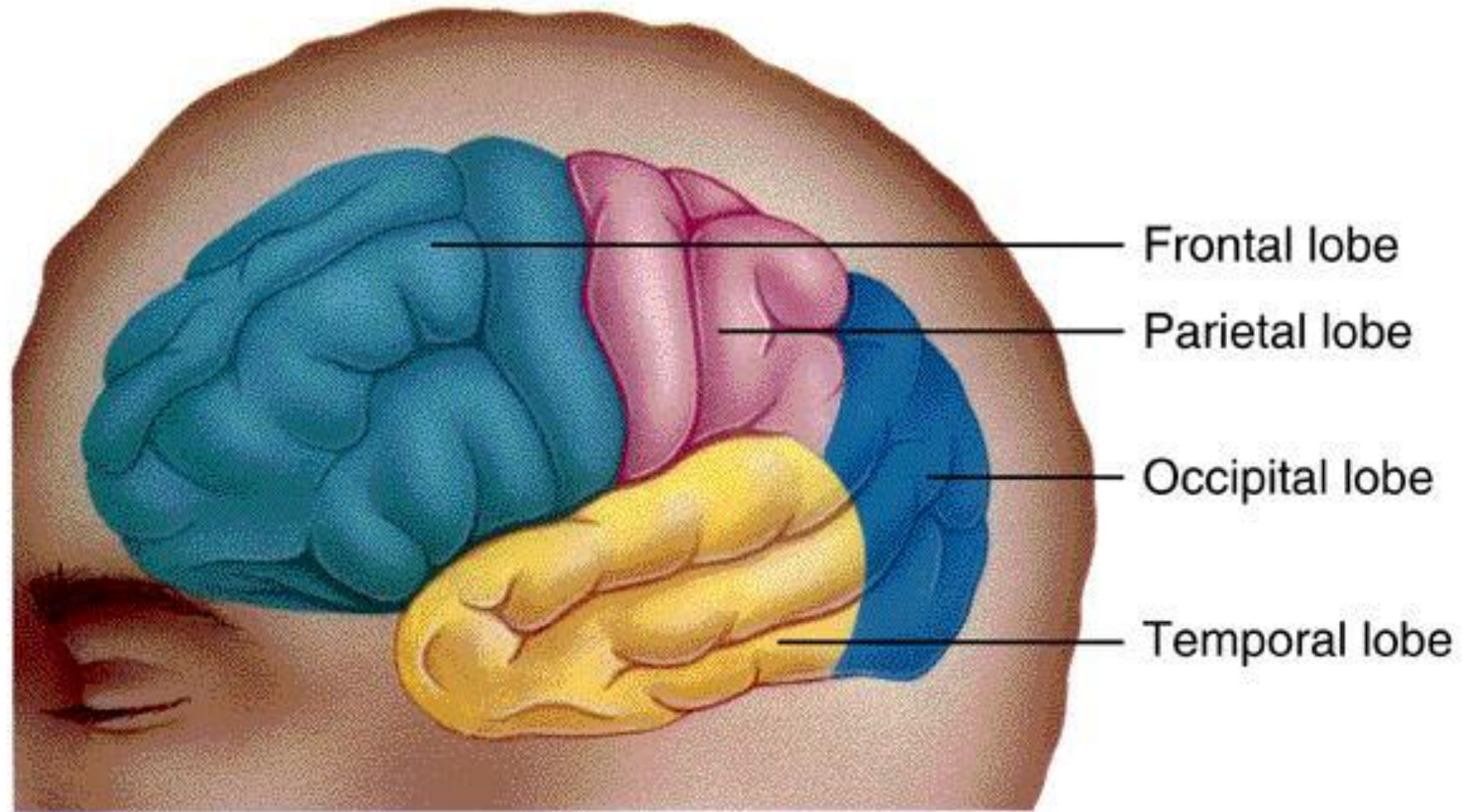

The common household brain

3. The cerebral hemispheres

b. Four lobes:

1. frontal
2. parietal
3. occipital
4. temporal

The common household brain

3. The cerebral hemispheres

b. Motor area

1. topographic organization--
Homunculus
2. contralateral control of body

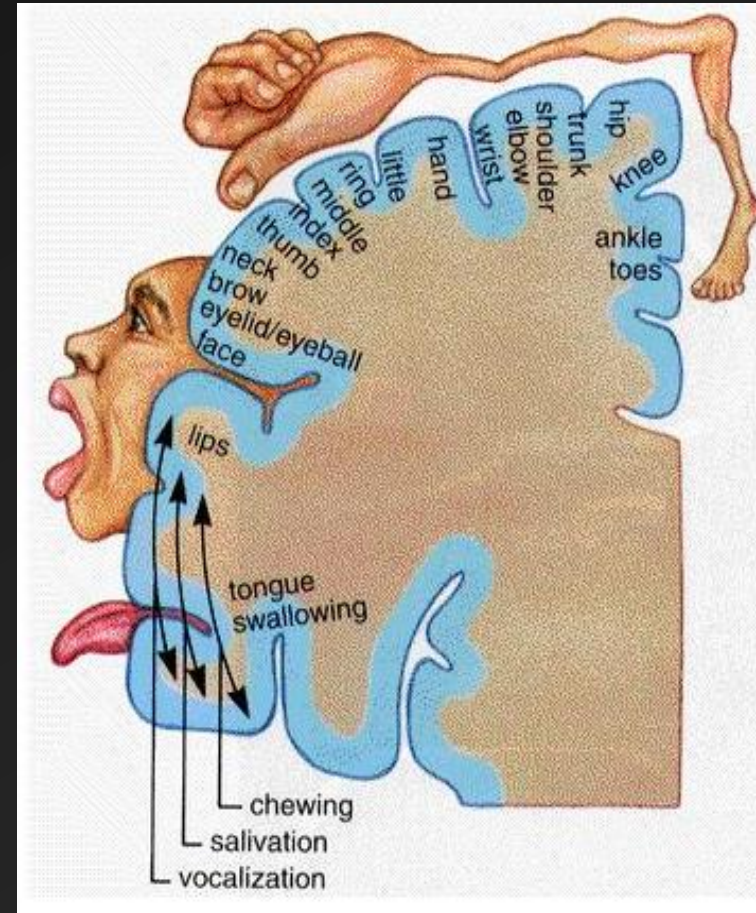

The common household brain

3. The cerebral hemispheres

d. Somatosensory area

1. heat, cold, touch, pain, sense of body movement
2. contralateral
3. space appropriated in accord to amount of use or need

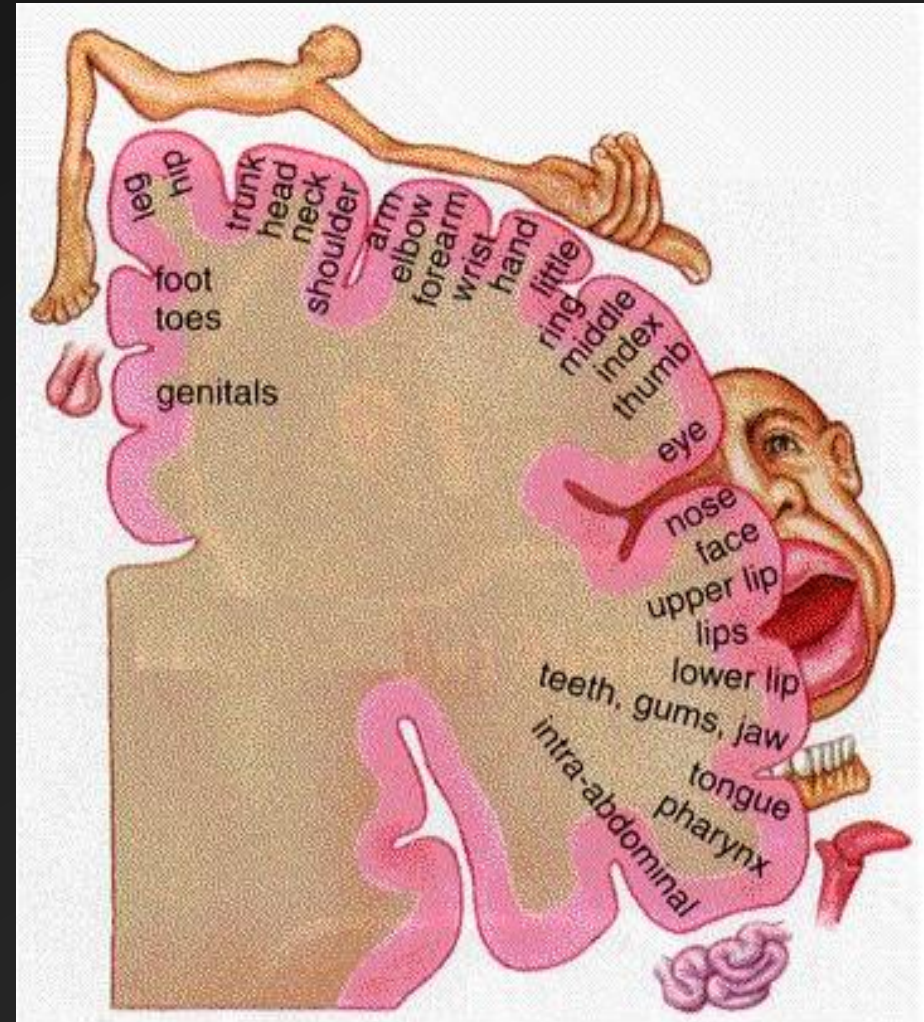

The common household brain

3. The cerebral hemispheres

e. Visual area

1. Contralateral visual field
2. Primary vs Secondary

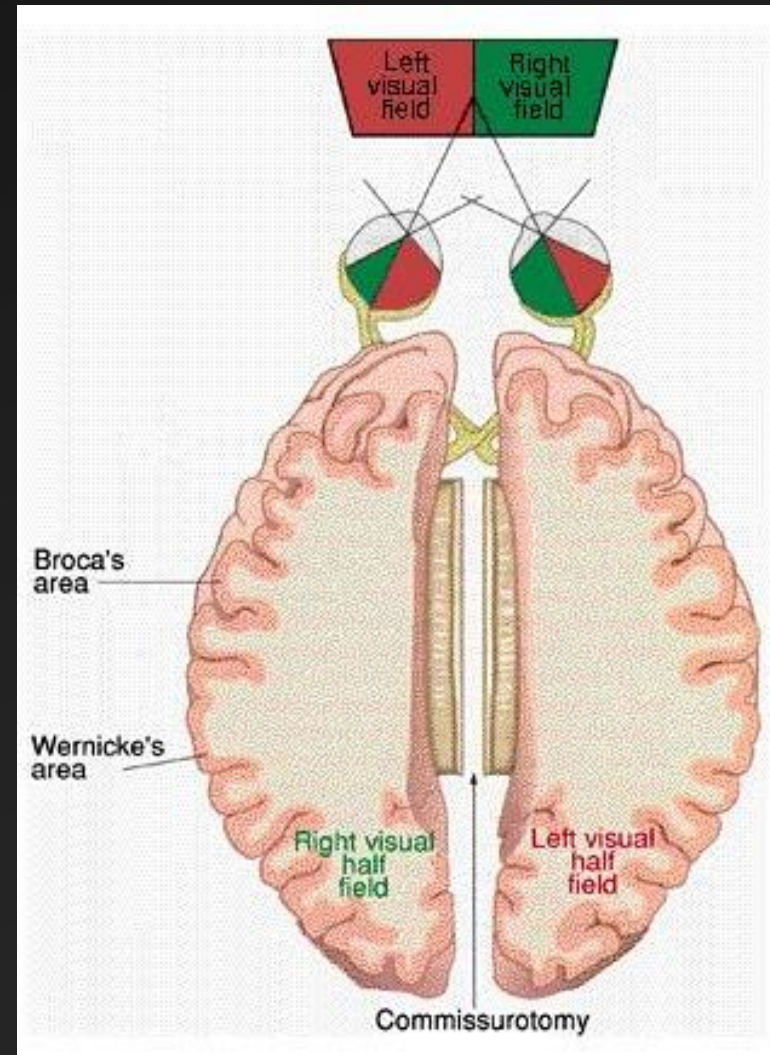

Visual cortex

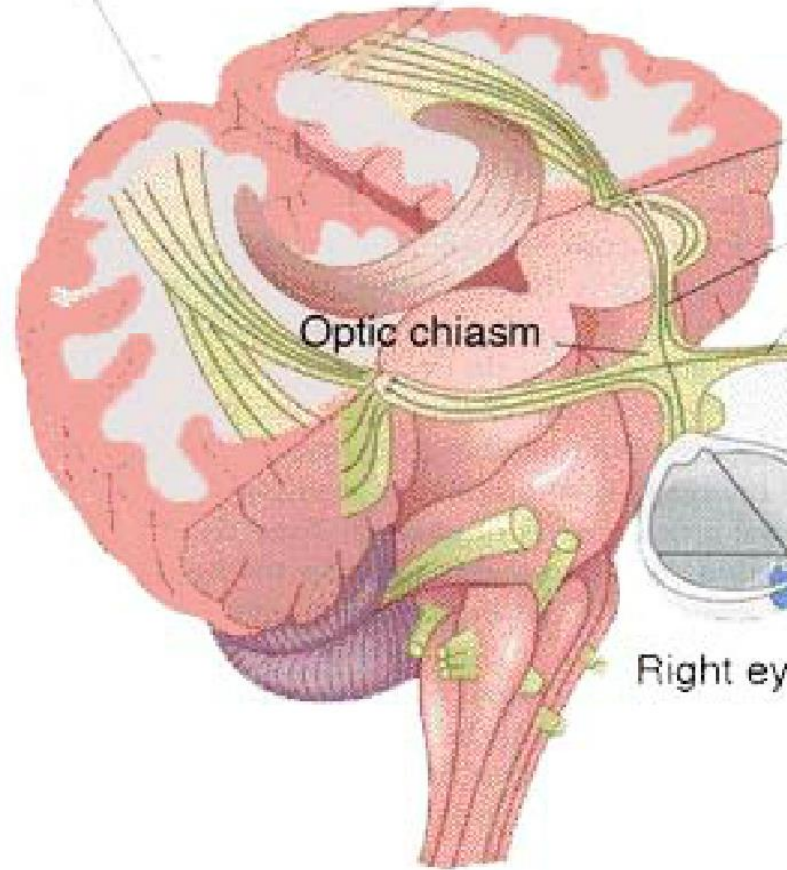

Lateral geniculate nucleus

Optic tract

Optic nerve

Optic chiasm

Left eye

Right eye

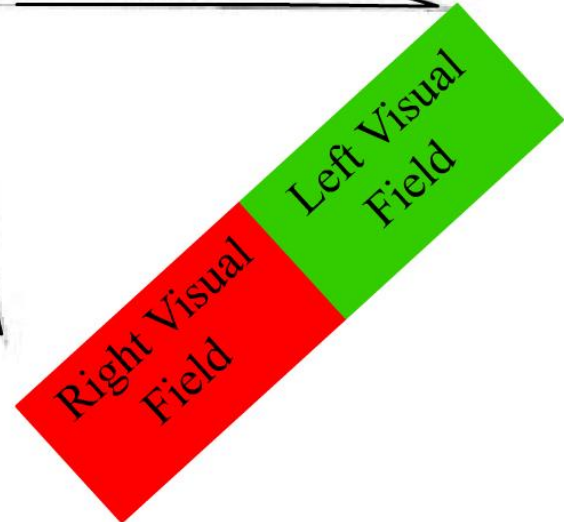

Right Visual Field

Left Visual Field

The common household brain

f. Auditory area

1. bilateral representation
2. contralateral stronger

Brown & Benchmark Introductory Psychology Electronic Image Bank copyright © 1995 Times Mirror Higher Education Group, Inc.

Four Lobes of the Cerebral Cortex

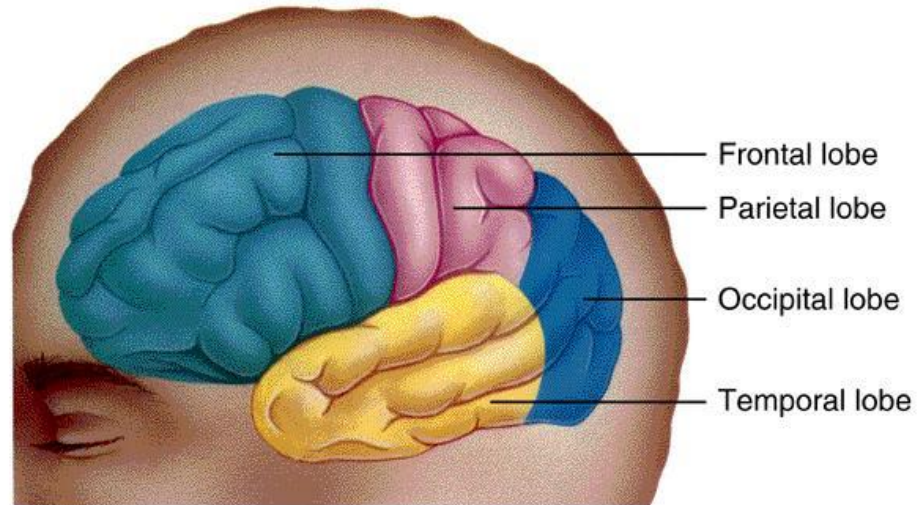

The common household brain

g. Association areas

1. functions which are not directly sensory or motor
2. Examples:
 - a. motor planning
 - b. thought
 - c. speech
 - d. problem solving
 - e. complex object recognition (e.g. prosopagnosia)
 - f. Phylogeny of Association Cortex

Luria's Functional Systems

1. **Primary**

a. Motor (precentral gyrus);
(1) topographic organization

b. **Sensory**

(1) Somatosensory (post central gyrus)

(2) Visual (Occipital cortex)

(3) Auditory (Banks of Lateral Sulcus)

Luria's Functional Systems

2. **Secondary**

- a. Motor (rostral to precentral gyrus): motor programming, sequences of movements

- b. Sensory (caudal to postcentral gyrus): **unimodal** sensory integration

Luria's Functional Systems

3. Tertiary

a. Motor (frontal lobes): goal directed acts, long-term & short-term planning, internal manipulation of "ideas" and representational systems that are basic to abstract thought

b. Sensory (parietal-temporal-occipital junction): **cross-modal** integration of sensory information

Four Lobes of the Cerebral Cortex

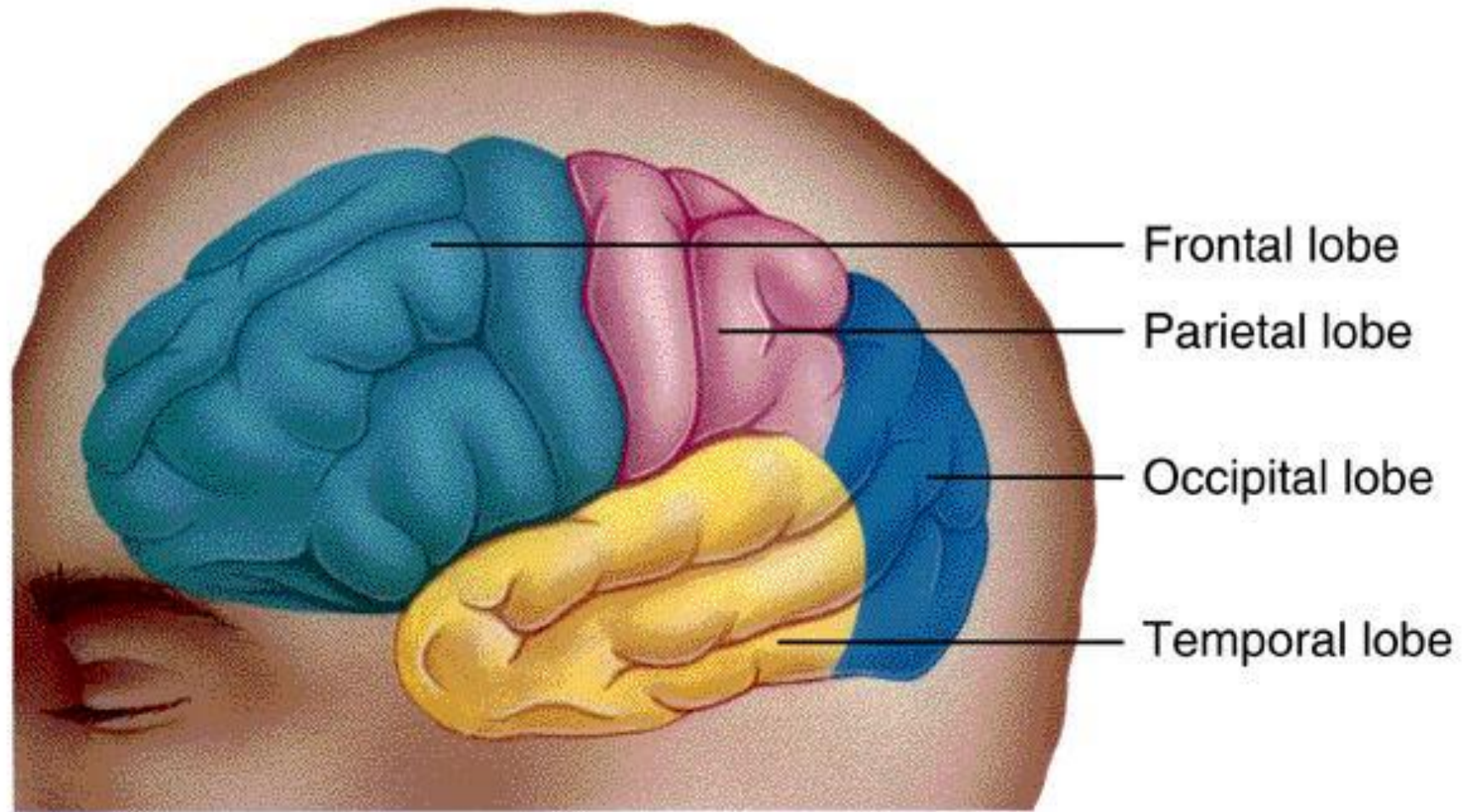

Frontal lobe

Parietal lobe

Occipital lobe

Temporal lobe



“The left side of your brain is good at math and science. The right side is creative and playful. You’ll get a raise as soon as you have the right side surgically removed.”